



Electronic Multi-Measuring Instrument

MODEL

# ME96SSRA-MB

User's Manual: Detailed Edition



- Before operating the instrument, you should first read thoroughly this operation manual for safe operation and optimized performance of the product.

Deliver this user's manual to the end user.

## Check on your delivery

Check the following point as soon as you receive Mitsubishi Electronic Multi-Measuring Instrument

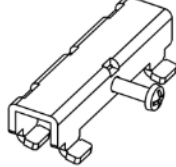
Parts name	Quantity	Specifications
User's Manual (Simplified)	1	 A3 size
Attachment lug (with screw)	2	

## About the optional plug-in module sold separately

This product has the following optional plug-in module.

It is possible to correspond to various I/O by installing the optional plug-in module.

We hope that you will order to us.

Type name of optional plug-in module	I/O specifications					
	Analog output	Pulse/Alarm output	Digital input	Digital output	Communication	Logging function
ME-4210-SS96	4 circuits	2 points	1 point	—	—	—
ME-0040C-SS96	—	—	4 points	—	CC-Link	—
ME-0052-SS96	—	—	5 points	2 points	—	—
ME-0000MT-SS96	—	—	—	—	MODBUS® TCP	—
ME-0000BU-SS96	—	—	—	—	—	6 items

<b>Note</b>	“ME-4201-NS96”, “ME-0052-NS96” and “ME-0040C-NS96” can not use in the ME96SSRA-MB. They can use for ME96NSR, ME96NSR-MB only.
-------------	---

I/O Parts	Specifications	Type name of optional plug-in module
Analog output	Output :4 to 20mA Load resistance :600Ω or less	ME-4210-SS96
Pulse/Alarm output	No-voltage 'a' contact Contact Capacity :DC35V, 0.1A or less	ME-4210-SS96
Digital input	Contact Capacity :DC24V(DC19 to 30V),7mA or less Input Pulse Width :30ms or more	ME-4210-SS96 ME-0040C-SS96 ME-0052-SS96
Digital output	No-voltage 'a' contact Contact Capacity :DC35V, 0.2A or less	ME-0052-SS96

In this manual, when the optional plug-in module is installed, it explains.

## Features

This instrument measures the load status by inputting the secondary side of the VT and CT, and displays various measurement values.

- This instrument supports active energy: class 0.5S and harmonic measurement up to 19th.
- This instrument enables measurement of integrated active energy divided into two time segments such as peak/off-peak and day/night. (Periodic Active Energy)
- This instrument enables measurement of the active energy in a block of any period (interval).( Rolling Demand)
- The password protection setting avoids undesired change of settings or deletion of measured data.
- The instruments with transmission functions (MODBUS® RTU communication, CC-Link communication, MODBUS® TCP communication) are able to transmit the measured data to superior monitoring devices.  
(CC-Link communication: When the ME-0040C-SS96 optional plug-in module is installed)  
(MODBUS® TCP communication: When the ME-0000MT-SS96 optional plug-in module is installed)
- Using the logging function, measurement data can be backup even when the MODBUS® RTU communication fails.  
(Logging function: When the ME-0000BU-SS96 optional plug-in module is installed)
- The instruments with analog/pulse output function are able to output key measurement factors (current, voltage, active power, power-factor, and Active Energy) of the power receiving point alone and are optimum for remote monitoring.(When the ME-4210-SS96 optional plug-in module is installed)
- This instrument complies with the requirements of the CE marking, UL standards, KC mark, and FCC/IC.

MODBUS® is a registered trademark of SCHNEIDER ELECTRIC USA, INC in the United States.

## Table of Contents

Check on your delivery .....	1
About the optional plug-in module sold separately.....	1
Features.....	2
Table of Contents.....	3
Safety Precaution .....	5
EMC Directive Instruction .....	9

## Instructions for Handling

1. Display and Button Functions of Each Parts .....	10
2. Function Modes .....	15
3. Setting.....	16
3.1. Setting flow.....	16
3.2. Setting Menu 1: Basic Settings (Setting the Phase Wire System, Display Pattern, VT/Direct Voltage, CT Primary Current, etc.) .....	22
3.3. Setting Menu 2: Communication Settings (Setting the MODBUS <sup>®</sup> RTU communication).....	26
3.4. Setting Menu 2: Communication Settings (Setting the CC-Link communication).....	27
3.5. Setting Menu 2: Communication Settings (Setting the MODBUS <sup>®</sup> TCP communication) .....	29
3.6. Setting Menu 3: Display Settings (Setting Maximum Scale, Active Energy Measurement, and Harmonic Display, etc.).....	31
3.7. Setting Menu 4: LCD Settings (Setting Model Display, Version Display, Backlight, and Display Update Time) .....	33
3.8. Setting Menu 5: Pulse and Alarm Settings (Setting Upper/Lower Limit Alarm, Motor Starting Current Mask Function, Pulse Output, etc.) .....	34
3.9. Setting Menu 6: Setting the Analog Output.....	39
3.10. Setting Menu 6: Setting the Logging function .....	42
3.11. Setting Menu 7: Setting Periodic Active Energy, Rolling Demand, and Digital Input/Output .....	44
3.12. Setting Menu 8:Special Settings (Setting Operation Time, Phase Display, IEC Mode).....	46
3.13. Setting Menu CL: Present Time Settings for Data Logging .....	48
3.14. Setting Value Confirmation Menus 1-9: Confirming the Settings in the Setting Menus 1-8 and Test Mode in Setting Menu 9.....	50
3.15. Initializing Related Items by Changing Settings .....	51
3.16. Initializing All Settings.....	52
3.17. Setting the Special Display Pattern P00 .....	53
3.18. Examples of Simple Settings .....	55
4. Using Test Mode .....	57
4.1. Test Menu 1: Communication Test .....	58
4.2. Test Menu 2: Alarm Output/Digital Output Operation Test.....	59
4.3. Test Menu 3: Zero Span Adjustment for Analog Output .....	60
4.4. Test Menu 4: Analog Output Operation Test.....	61
4.5. Test Menu 5: Pulse Output Operation Test.....	62
5. Operation .....	63
5.1. Basic Operation.....	63
● Switch display.....	63
● Switch phase .....	63
● Bar graph display .....	64
● Switching measurement factors displayed on bar graphs .....	64
● Cyclic Display .....	65
● Harmonics display .....	65
● Maximum value and minimum value display .....	67
● Display of maximum value and minimum value.....	67
● Clear the maximum/minimum value.....	67
● Active Energy / Reactive Energy / Apparent Energy Display.....	68
● How to change the unit of Wh, varh and VAh .....	68
● Wh, varh and VAh zero reset .....	68
● Reactive energy counting method (2 quadrant counting / 4 quadrant counting) .....	69
● Each measurement item display during power transmission.....	69
● Demand time and demand value of current demand.....	70

## Table of Contents

5.2. Usage According to Purpose (Alarm, Periodic Active Energy, Rolling Demand, Operating Time, Password, etc.).....	71
● Display and operation of the upper/lower limit alarm .....	71
● Canceling the upper/lower limit alarm .....	72
● Stopping backlight flickering caused by upper/lower limit alarm generation.....	72
● Upper/lower limit alarm items on the alarm contacts .....	72
● Display of periodic active energy .....	72
● Resetting periodic active energy to zero .....	72
● Display and calculation of rolling demand.....	73
● Adjusting rolling demand time .....	74
● Resetting the peak value of rolling demand .....	74
● Display of operation time.....	74
● Resetting the operation time to zero .....	74
● Display and operation of digital input/output status .....	75
● Releasing the digital input latch .....	75
● Preventing maximum value update by motor starting current .....	75
● Password protection setting .....	76
6. Other.....	77
6.1. Display Pattern Contents .....	77
6.2. Maximum Scale Value.....	79
6.3. Possible Setting Range for Maximum Scale .....	80
6.4. Measurement Items and Correspondence between Display and Output .....	83
6.5. Measurement Characteristic .....	84
6.6. Troubleshooting.....	85

## Installation

Installation 1. Dimensions.....	87
Installation 2. Mounting.....	89
Installation 3. Wiring .....	90
Installation 4. Wiring Diagram.....	92
Installation 5. How to insert and eject the SD memory card (ME-0000BU-SS96) .....	100

## Specifications

Specifications.....	101
1. Specification .....	101
2. Applicable Standards.....	102
3. Specifications of MODBUS <sup>®</sup> RTU Communication.....	102
4. Specifications of CC-Link Communication .....	102
5. Specifications of MODBUS <sup>®</sup> TCP Communication.....	103
6. Specifications of Logging.....	103
7. Setting Table (Factory Settings and Customer Setting Note).....	104

Appendix.....	106
1. Calculation methods of ME96SS (for 3 phase unbalanced system with neutral) .....	106
2. Optional part (Available part).....	107

Service Network.....	108
----------------------	-----

## Safety Precaution

(Always read these instructions before using this equipment)

For personnel and product safety please read the contents of these operating instructions carefully before using. Make sure that the end users read this manual and then keep the manual in a safe place for future reference. Make sure to deliver this manual to the end-user.

If you are considering using this instrument for special purpose such as nuclear power plants, aerospace, medical care or passenger vehicles please refer to our sales representative.

### HAZARD SYMBOLS



Read these instructions carefully and look at the equipment to become familiar with the device before trying to install, operate, service or maintain it. Terminal of control power (MA, MB) and voltage inputs (P1, P2, P3, PN) have hazards of electric shock, explosion, or arc flash. Turn off power supplying this device and the equipment in which it is installed before working on it.

### CAUTION

The above indicates that incorrect handling may cause hazardous conditions. Always follow the instructions because they are important to personal safety. Otherwise, it could result in electric shock, fire, erroneous operation, and damage of the instrument. If the equipment is used in a manner not specified by the manufacturer, the protection provided by the equipment may be impaired.

#### ■ Normal service conditions

Use the instrument in an environment that meets the Normal service conditions as following points:

- Ambient temperature: -5 to +55°C
- Average day temperature: 35°C or less
- Humidity: 0 to 85%RH, non condensing.
- Altitude: 2000m or less
- Pollution Degree: 2 or less (Note 1)
- Atmosphere without corrosive gas, dust, salt, oil mist.
- Indoor use
- Transient over voltage: 4000V or less (Note 1)
- A place without excessive shocks or vibration.
- Do not expose to rain and water drips.
- Do not expose to direct sunlight.
- An area in where no pieces of metal and an inductive substance disperse.
- Do not expose to strong electromagnetic field and ambient noises.

Note 1. For the definition of the Pollution Degree and the Transient over voltage category, refer to EN61010-1:2010.

#### ■ Installation instructions

Make sure to read this manual carefully before Installation and Wiring.

CAUTION	<ul style="list-style-type: none"> <li>● This instrument should be installed and used by a qualified electrician.</li> <li>● The instrument must not be powered and used until its definitive assembly on the cabinet's door.</li> <li>● The instrument is to be mounted on a panel. All connections must be kept inside the cabinet.</li> <li>● Verify the following points:               <ul style="list-style-type: none"> <li>■ Auxiliary power supply and measuring ratings.</li> </ul> </li> </ul>				
	Auxiliary power supply		AC100-240V(±15%) 50-60Hz 8VA DC100-240V(-30% +15%) 5W		MA,MB terminals
	Ratings	Voltage	3-PHASE 4-WIRE : max AC277/480V 3-PHASE 3-WIRE : (DELTA)max AC220V, (STAR)max AC440V 1-PHASE 3-WIRE : max AC220/440V 1-PHASE 2-WIRE : (DELTA)max AC220V, (STAR)max AC440V	Category III	P1,P2,P3,PN terminals
		Current	5A(via current transformer),maxAC30V	Category III	+C1,C1,+C2,C2,+C3,C3 terminals
	Frequency	50-60Hz			
<p>Provide the basic insulation externally at the current input terminals. Voltage-measuring and current-measuring circuit terminals should be permanently connected.</p>					

## Safety Precaution

### ■ Others

MODBUS <sup>®</sup> RTU communication	T/R+, T/R-, SG, Ter terminals	maxDC35V
MODBUS <sup>®</sup> TCP communication	Ethernet terminals	
CC-Link communication	DA, DB, DG terminals	
Digital input	DI1, DI2, DI3, DI4, DI COM, DI+, DI-, DI1+, DI1-, DI2+, DI2-, DI3+, DI3-, DI4+, DI4-, DI5+, DI5- terminals	
Digital output	DO1+, DO1-, DO2+, DO2- terminals	
Analog output	CH1+, CH1-, CH2+, CH2-, CH3+, CH3-, CH4+, CH4- terminals	
Pulse/ Alarm output	C1A/A1, C1B/COM1, C2A/A2, C2B/COM2 terminals	



- Do not drop this instrument from high place. If you drop it and the display is cracked, do not touch the liquid crystal or get it in your mouth. If the liquid crystal is touched, wash it away at once.
- Work under the electric outage condition when installing and wiring. It may cause electric shock, electric burn injury or damage of the device.
- When tapping or wiring, take care not to entering any foreign objects such as chips and wire pieces into this instrument.
- If the terminal wiring is pulled with a strong force, the terminals may detach. (Tensile load: 39.2N or less)
- When wiring in this instrument, be sure that it is done correctly by checking the instrument 's wiring diagram. Wrong wiring may cause failure of the instrument, a fire or electric shock.
- Use electrical wire sizes compatible with the rated current. Use of unsuitable sizes may cause heat generation, which may lead to a fire.
- Tighten the terminal screws with the specified torque and use the suitable pressure connectors and suitable wire size. (Refer to page 90)
- In order to prevent invasion of noise, do not bunch the control wires or communication cables with the main circuit or power wire, or install them close to each other. The distance between communicational signal lines, input signal lines and power lines, and high voltage lines when running parallel to each other are shown below.

Conditions	Length
Below 600V, or 600A power lines	30cm or more
Other power lines	60cm or more

- Protective conductor terminals for mains circuits shall be at least equivalent in current-carrying capacity to the mains supply terminals.
- If the protective conductor terminals are also used for other bonding purposes, the protective conductor shall be applied first and secured independently of other connections.

### ■ Matters concerning the precaution before use

- Use the instrument in the specified usage environment and conditions.
- The setting of this instrument is necessary before use it. Please read this manual carefully to ensure correct setting.
- Confirm the rating of this instrument, and supply power voltage within the specified range.

## Safety Precaution

### ■ Operation instructions

- Before operating the product, check that active bare wire and so on does not exist around the product. If any bare wire exists, stop the operation immediately, and take an appropriate action such as isolation protection.
- In the event of a power outage during the setting, the instrument is not set correctly. Please set again after power recovery.

	<ul style="list-style-type: none"><li>● Do not disassemble or modify this instrument. It may cause failure, malfunction, injury or fire.</li><li>● Use this instrument within the ratings specified in this manual. If it is used outside the ratings, it may cause not only malfunction or failure but also fire burnout.</li><li>● Do not open the secondary side of the CT circuit. If the CT is not connected properly or if the secondary side of the CT is open, it may result in high voltage on the secondary side of the CT, the insulation of the secondary winding wire may be damaged, and burnout may be caused.</li><li>● When the external terminals are connected to the external equipment, the instrument and the external equipment must not be powered and used until its definitive assembly on the cabinet's door.</li><li>● The rating of the terminal of the external equipment should satisfy the rating of the external terminal of this instrument.</li></ul>
---	--

### ■ Maintenance instructions

- Wipe dirt off the surface with a soft dry cloth.
- Do not contact a chemical dust cloth to the instrument for a long time, or do not wipe it with benzene, thinner, alcohol.
- Check for the following items to use this instrument properly for long time.
  - (1)Daily maintenance
    - ①No damage on this instrument
    - ②No abnormality with LCD indicators
    - ③No abnormal noise, smell or heat
  - (2)Periodical maintenance (Once every 6 months to 1 year)
    - No looseness with installation and wire connection

	Do periodical maintenance under the electric outage condition. Failure to do so may cause electric shock, failure of the instrument or a fire. Tighten the terminal regularly to prevent a fire.
---	--

### ■ Storage conditions

To store this instrument, turn off the power and remove wires, and put it in a plastic bag.

For long-time storage, store at the following places. Failure to follow the instruction may cause a failure and reduced life of the instrument.

- Ambient temperature the: -25 to +75°C
- average day temperature: 35°C or less
- Humidity range 0 to 85%RH, non-condensing.
- Atmosphere without corrosive gas, dust, salt, oil mist.
- A place without excessive shocks or vibration.
- Do not expose to rain and water drips.
- Do not expose to direct sunlight.
- An area in where no pieces of metal and an inductive substance disperse.



## Safety Precaution

### ■ Guarantee

- Gratis warranty is effective until the earlier of 1 year after the date of your purchase or 18 months after manufacturing.
- The gratis warranty shall apply if the product fails even though it is being used properly in the conditions, with the methods and under the environments in accordance with the terms and precautions described in the catalogs, the instruction manual, caution label on the product, etc.
- Repair shall be charged for the following cases even during the gratis warranty period.
  - ① Failures occurring due to your improper storage or handling, carelessness or fault.
  - ② Failures due to faulty workmanship
  - ③ Failures due to faults in use and undue modification
  - ④ Failures due to accidental force such as a fire, abnormal voltage, etc. and force majeure such as an earthquake, wind, flood, etc.
  - ⑤ Failures due to matters unpredictable based on the level of science technology at the time of product.
- Our company shall not be liable to compensate for any loss arising from events not attributable to our company, opportunity loss and lost earning of the customer due to failure of the product, and loss, secondary loss, accident compensation, damage to other products besides our products and other operations caused by a special reason regardless of our company's predictability

### ■ Replacement Cycle

Although it depends on the status of use, 10 years is the guideline for renewal.

### ■ Disposal

- When disposing of this product, treat it as industrial waste.
- A lithium battery is embedded in the optional plug-in module: ME-0000BU-SS96. Lithium batteries are disposed of according to local regulation.
- In EU member states, there is a separate collection system for waste batteries. Dispose of batteries properly at the local community waste collection/recycling center.  
The symbol shown below is printed on the packaging of ME-0000BU-SS96.



Note: This symbol is for EU member states only.

The symbol is specified in the new EU Battery Directive (2006/66/EC) Article 20 "Information for end-users" and Annex II.

The symbol indicates that batteries need to be disposed of separately from other wastes.



A lithium battery is embedded in the optional plug-in module: ME-0000BU-SS96. Therefore, if it will be thrown in fire, evolution of heat, burst or ignition may occur. Lithium batteries are disposed of according to local regulation.

### ■ About packaging materials and this manual

For reduction of environment load, packaging materials are produced with cardboard, and this manual is printed on recycled paper.

## EMC Directive Instruction

This section summarizes the precautions on conformance to the EMC Directive of the cabinet constructed using this instrument.

However, the method of conformance to the EMC Directive and the judgment on whether or not the cabinet conforms to the EMC Directive has to be determined finally by the manufacturer.

This instrument complies with part 15 of the FCC Rules. Operation is subject to the following two conditions: (1) This instrument may not cause harmful interference, and (2) this instrument must accept any interference received, including interference that may cause undesired operation.

### 1. EMC Standards

- EN 61326-1
- EN 61000-3-2
- EN 61000-3-3

### 2. Installation (EMC directive)

The instrument is to be mounted on panel of a cabinet.

Therefore, the construction of a cabinet is important not only for safety but also for EMC.

The instrument is examined by the following conditions.

- Conductive cabinet is used.
- Six faces of a cabinet have to be ensured conductivity for each other.
- A cabinet has to be connected to earth by a thick wire of low impedance.
- Holes on faces of cabinet have to be 10 cm or less in diameter.
- The terminals for protective earth and functional earth have to be connected to earth by a thick wire of low impedance. (A terminal for protective earth is important not only for safety but also for EMC.)
- All connections must be kept inside the cabinet.
- Wirings outside the cabinet have to be used with the shielded cable.

The following diagram shows how to provide good contact of the shielded cable.

- Remove part of the outer cover.
- Remove part of the paint mask on the cabinet.
- Connect those parts with the clamp.

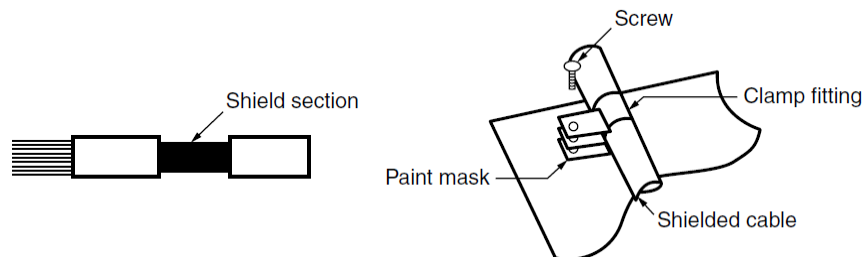

# 1. Display and Button Functions of Each Parts

## Part names

### ■Front view

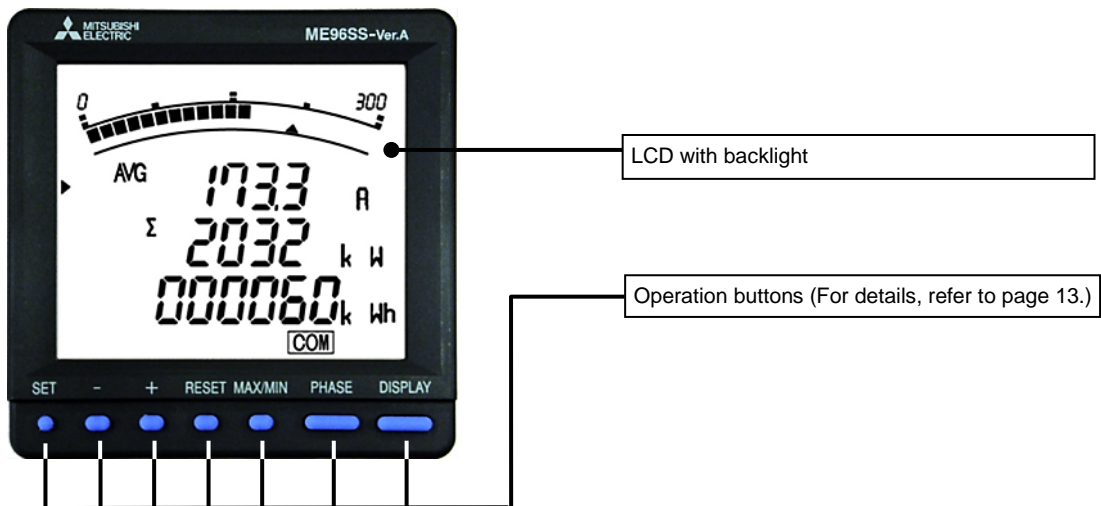

### ■Rear view (main unit)

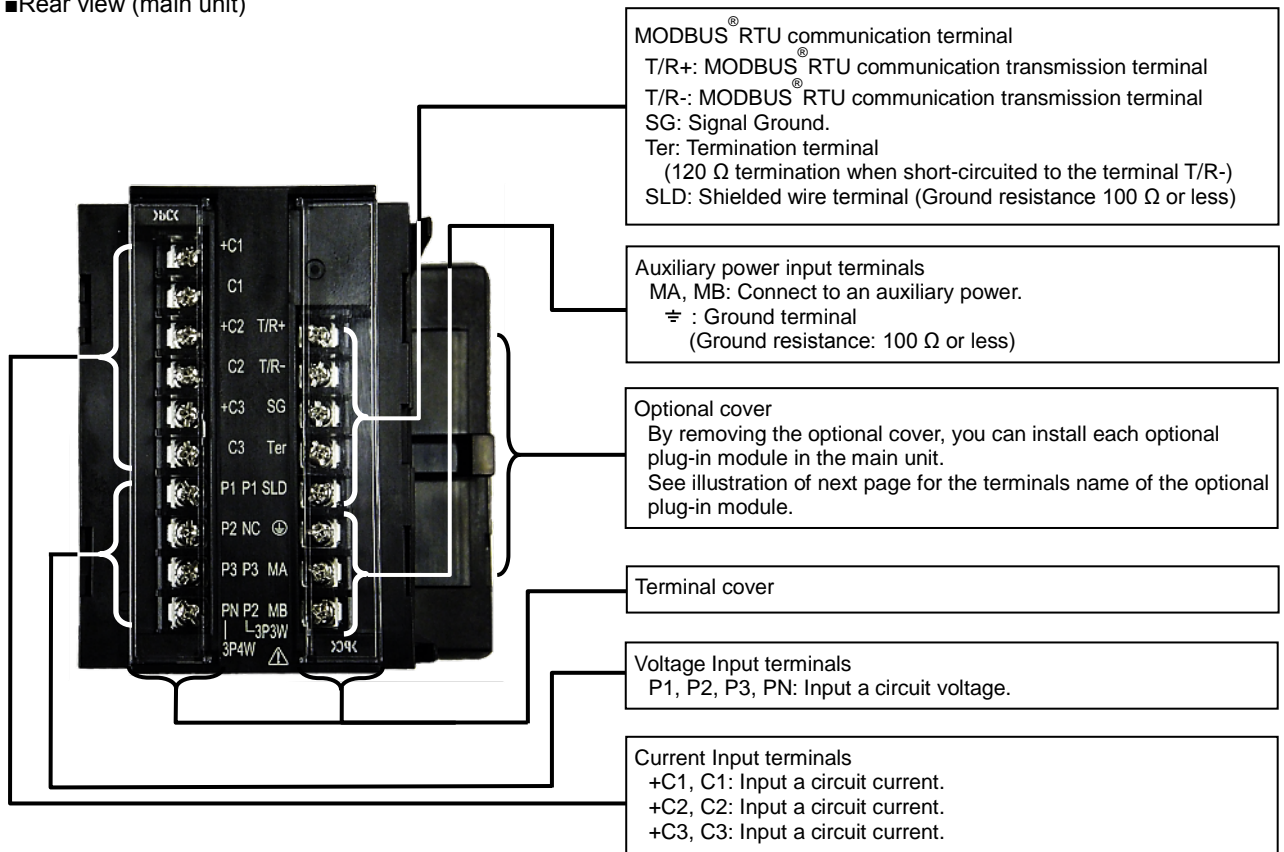

# 1. Display and Button Functions of Each Parts

## Part names

■Rear view (Optional plug-in module: ME-4210-SS96, ME-0040C-SS96, ME-0052-SS96)

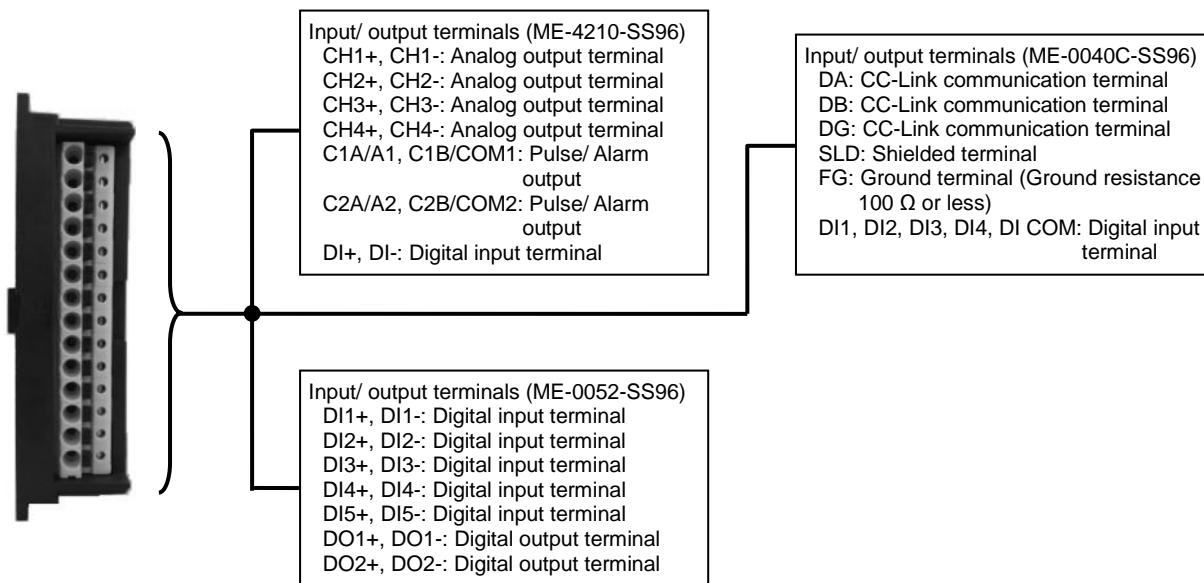

■Side/Rear view (Optional plug-in module: ME-0000MT-SS96)

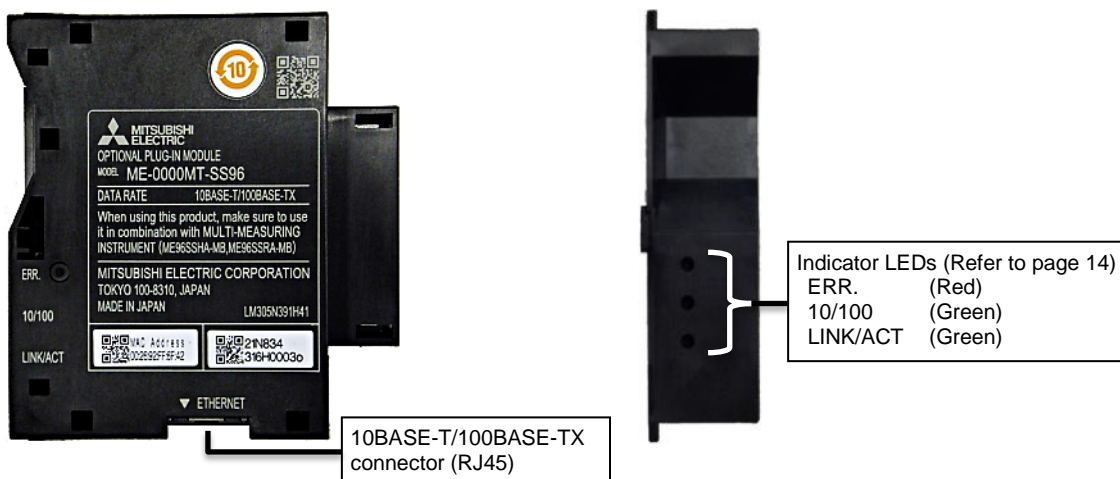

■Side/Rear view (Optional plug-in module: ME-0000BU-SS96)



# 1. Display and Button Functions of Each Parts

## Display

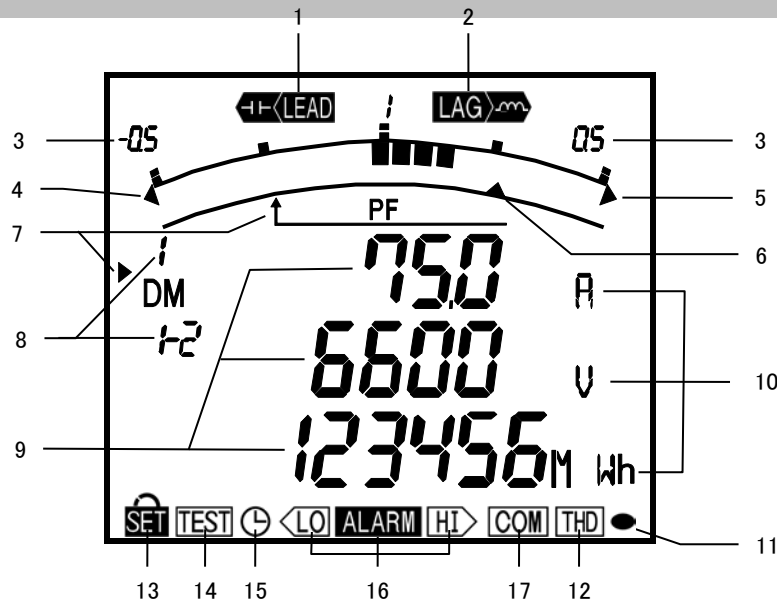

Note: The above display is an example for explanation.

No.	Segment Name	Description																
1	LEAD status	They show direction of Power Factor or Reactive Power on bar graph.																
2	LAG status	They show the type of counting of Reactive Energy on Reactive Energy Display.																
3	Scale of the bar graph	They show the scales of the bar graph.																
4	Under scale input	Turns on when measuring values fall below the minimum scale.																
5	Over scale input	Turns on when measuring values exceed the maximum scale.																
6	Index indicator	When upper/lower limit alarm set, flickers at the limit setting value.																
7	Bar graph status	They show the item expressed with the bar graph. When the item is the same as a digital displayed item, indicated with「▶」, otherwise indicated with「▲」																
8	Phase status	They show the phase for each of the digital displays.																
9	Digital display	Measured values displayed in digital.																
10	Unit	Units of measuring value displayed.																
11	Metering status	Flickers when counting active energy.(Note.1)(only active energy imported display)																
12	Harmonics	Turns on when harmonics displayed.																
13	Setup status	Turns on at setting mode. (SET) Flickers at setting value confirmation mode. (SET)																
14	Test mode status	Turns on at the test mode.																
15	Clock status	Turns on when Operation time displayed.																
16	Upper/lower limit alarm status	Flickers when upper/lower limit alarm is generated.																
17	Communication or Logging status	<table border="1"> <thead> <tr> <th>Specification</th> <th>On</th> <th>Blinking</th> <th>Off</th> </tr> </thead> <tbody> <tr> <td>CC-Link communication</td> <td>Normal</td> <td>CC-Link version mismatch Hardware error</td> <td>Hardware error</td> </tr> <tr> <td>MODBUS®RTU communication MODBUS®TCP communication</td> <td>Normal</td> <td>Communication error (Such as wrong address)*1</td> <td>Hardware error</td> </tr> <tr> <td>Logging function</td> <td>Normal</td> <td>Error such as incorrect setting, SD memory card error, low battery voltage)*1</td> <td>Hardware error</td> </tr> </tbody> </table>	Specification	On	Blinking	Off	CC-Link communication	Normal	CC-Link version mismatch Hardware error	Hardware error	MODBUS®RTU communication MODBUS®TCP communication	Normal	Communication error (Such as wrong address)*1	Hardware error	Logging function	Normal	Error such as incorrect setting, SD memory card error, low battery voltage)*1	Hardware error
Specification	On	Blinking	Off															
CC-Link communication	Normal	CC-Link version mismatch Hardware error	Hardware error															
MODBUS®RTU communication MODBUS®TCP communication	Normal	Communication error (Such as wrong address)*1	Hardware error															
Logging function	Normal	Error such as incorrect setting, SD memory card error, low battery voltage)*1	Hardware error															

\*1. For details, refer to Section 6.6.(page86).

Note 1. The blinking cycle is constant regardless of the size of the measured input.

# 1. Display and Button Functions of Each Parts

## Functions of operation buttons

The operation buttons have various functions according to how they are pressed down.

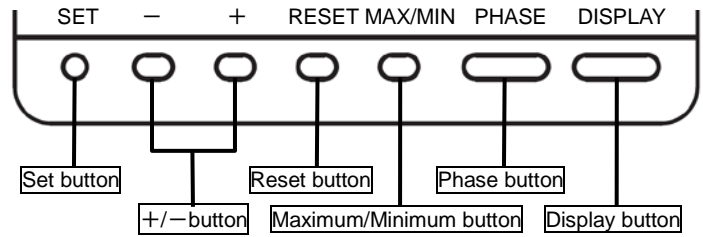

Meaning of code: ○(press), □(press on over 1 second), ⊙(press on over 2 seconds), —(press simultaneously)

Operation Mode	Button							Function			
	SET	-	+	RESET	MAX/MIN	PHASE	DISPLAY				
Operation mode	Display changes operation							○	Display changes.		
			○	—					○	Display changes.(reverse direction)	
								○		Phase changes.	
						○				Mode changes to the max./min. display and the instantaneous display	
			○	○						The item expressed with the bar graph is changed. Harmonics number changes when harmonics displayed.	
									⊙	Displays change cyclically. (Refer to page 65)	
								⊙		Phases change cyclically. (Refer to page 65)	
			⊙	—	⊙					Change the unit of Wh, varh and VAh, etc. (Refer to page 68)	
	Measured value is reset/ Canceling the alarm, etc				⊙					Maximum values and minimum values on the display are reset to the present value. Only available for maximum/minimum value display	
				⊙	—	⊙				All of the Maximum values and minimum values are reset to the present value.	
		⊙	—	—	⊙	—	⊙			Wh, varh, VAh are zero reset. (All of the counting values are zero reset.)	
				⊙	—	⊙				Periodic active energy is zero reset. (Only effective in Periodic active energy display)	
			⊙	—	⊙					Adjusting rolling demand time(Only effective in rolling demand display)	
				⊙	—	⊙				Resetting the peak value of rolling demand (Only effective in rolling demand display)	
					⊙					The operation time is zero reset (Screen operation time only)	
					○					An alarm condition is canceled. (Screen element is canceled) Available only when manual cancelation is set	
					⊙					All alarm conditions are canceled. (Element is canceled for all screens)	
					○					Stopping backlight flickering alarm. (Only effective in setting backlight flicker)	
	Mode changes				⊙					The latching data of digital input on the display is canceled. (Available only for contact point input screen)	
		⊙	—	—	⊙					The display of Setting mode appears.	
		⊙								The display of Set value confirmation mode appears.	
	Setting/ Setting value confirmation mode	Setting operation				⊙	—	⊙		The display of password protection mode appears.	
			○							The setting items are saved, and setting item is changed to next item.	
									○		Back to the previous item.
				○	○						The values of setting are changed. (If it presses for 1 sec or more fast forward or fast return.)
			□								Back to the setting display.
			○								Save the settings(Only effective in End display)
		○								Cancel the settings(Only effective in CANCEL display)	
Special operation					□	—	□		Meter restart(Only effective in CANCEL display)		
				⊙	—	⊙			Returns set contents to the default settings (the default values, Only effective in CANCEL display) (Refer to page 52)		

Note: While the back light is off, if the operation button is pressed, the back light is always lit. If the operation button is pressed once again, the function in the above table appears.



- If the function of "maximum value and minimum value reset" and "Wh, varh, VAh zero reset" are done, data will be lost. If this data is needed, please record the data before the reset operation.
- If the function of "meter restart" is done, the entire measurement(measurement display, alarm, analog output, pulse) stops.

# 1. Display and Button Functions of Each Parts

## LEDs of the Optional plug-in module

### ■LEDs of ME-0000MT-SS96

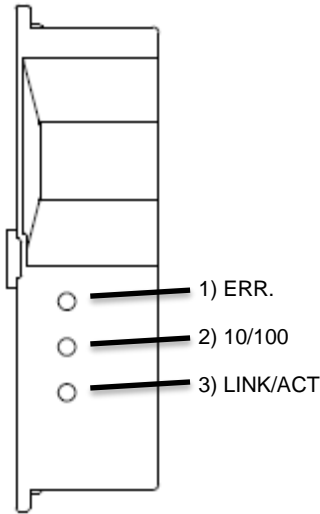

No.	Name	Function
1)	ERR. LED	This indicates a communication error state of ME-0000MT-SS96
	OFF	Normal
	Blink	MODBUS TCP® communication error as follows was detected. ·MODBUS TCP® application protocol header was incorrect. ·Function code was incorrect(Serial only code was received), etc. When correct request is received, this LED turns off.
2)	10/100 LED	This indicates the transmission speed.
	ON	100Mbps or not connected.
	OFF	10Mbps
3)	LINK/ACT LED	This indicates the link status.
	ON	Link is good.
	Blink	Blinks when data send or receive.
	OFF	Not linked

### ■LEDs of ME-0000BU-SS96

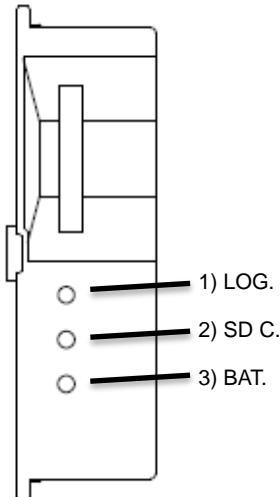

No.	Name	Function
1)	LOG. LED	This indicates a state of logging operation.
	ON	Logging is running.
	OFF	Logging is stopped.
	Blink slowly (0.5s:on/0.5s:off)	Change of logging condition settings finished. Blink of LED lasts 5 second.
	Blink quickly (0.25s:on/0.25s:off)	When Setting of Logging-item pattern is LP00, Setting data file needed to store in SD memory card was incorrect. LED blinks until correct setting is done.
2)	SD C. LED	This indicates a state of communication with the SD memory card.
	ON	Communicating
	OFF	Stop communicating
	Blink quickly (0.25s:on/0.25s:off)	SD memory card error. Check whether the SD memory card is write-protect and SD memory card capacity is sufficient or not.
3)	BAT. LED	This indicates a state of battery voltage.
	OFF	Normal
	ON	The battery is low voltage.

## 2. Function Modes

The following function modes are available for this Multi-Measuring instrument. Operation mode is displayed after auxiliary power turns on. It is then possible to switch to the desired mode.

Mode	Description	Reference Pages
Operation Mode	This mode is for displaying each measured value using digital numerical values and bar graphs. Operation mode contains "Current Value Display" that displays the current value, and "Maximum/Minimum Value Display" that displays old maximum/minimum values. In addition, for each display, the cyclic display function can be used to switch between the screens every 5 seconds.	P.63 to P.76
Setting Mode	This mode is for changing the setting values related to measurement and output functions. The following special operations can be executed from the "CANCEL Display" for changing/cancelling setting values. <ul style="list-style-type: none"> <li>●The instrument is reset.</li> <li>●Reset the settings to the factory defaults</li> </ul>	P.16 to P.49 P.51 to P.56
Setting Value confirmation mode (Test Mode)	This mode is for confirming the setting values for each setting item.(In this mode, settings cannot be changed in order to prevent accidental changing of settings.) This mode contains test functions that can be used for equipment startup. <ul style="list-style-type: none"> <li>●Analog Output Adjustment: Analog output can be adjusted (zero adjustment and span adjustment).</li> <li>●Output Test: Analog output can be switched, pulse output can be executed, and alarm contact points can be opened/closed without measurement input (voltage/current).</li> <li>●Communication Test: Fixed numerical data can be returned without measurement input (voltage/current).</li> </ul>	P.50, P.57 to P.62

### ■ Diagram of Each Mode

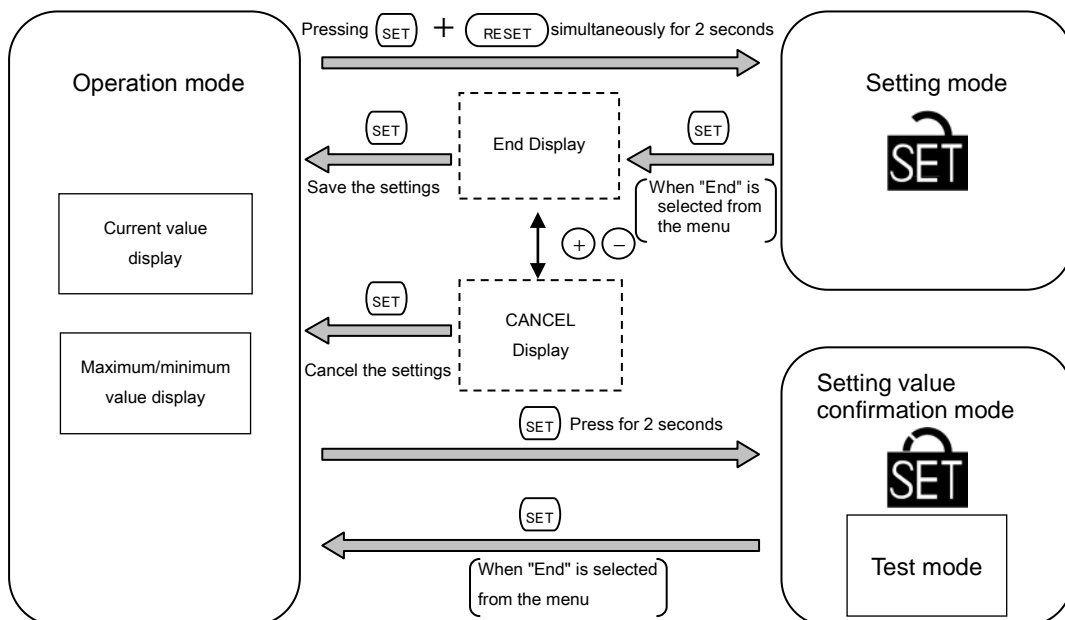



### 3. Setting

#### 3.1. Setting flow

To measure, it is necessary to use Setting mode to set the phase wire system, VT / direct voltage, and CT primary current. From Operation mode, move to Setting mode and then set necessary items. Factory default settings will be used for items that you do not set.

Only the settings in Setting menu 1 (basic setting) are needed for normal use. For more information about the settings, refer to page 22 and after.

For more information about the factory default settings, refer to the setting table on page 104.

■ Setting flow when without optional plug-in module, with ME-4210-SS96, with ME-0040C-SS96 or with ME-0052-SS96,

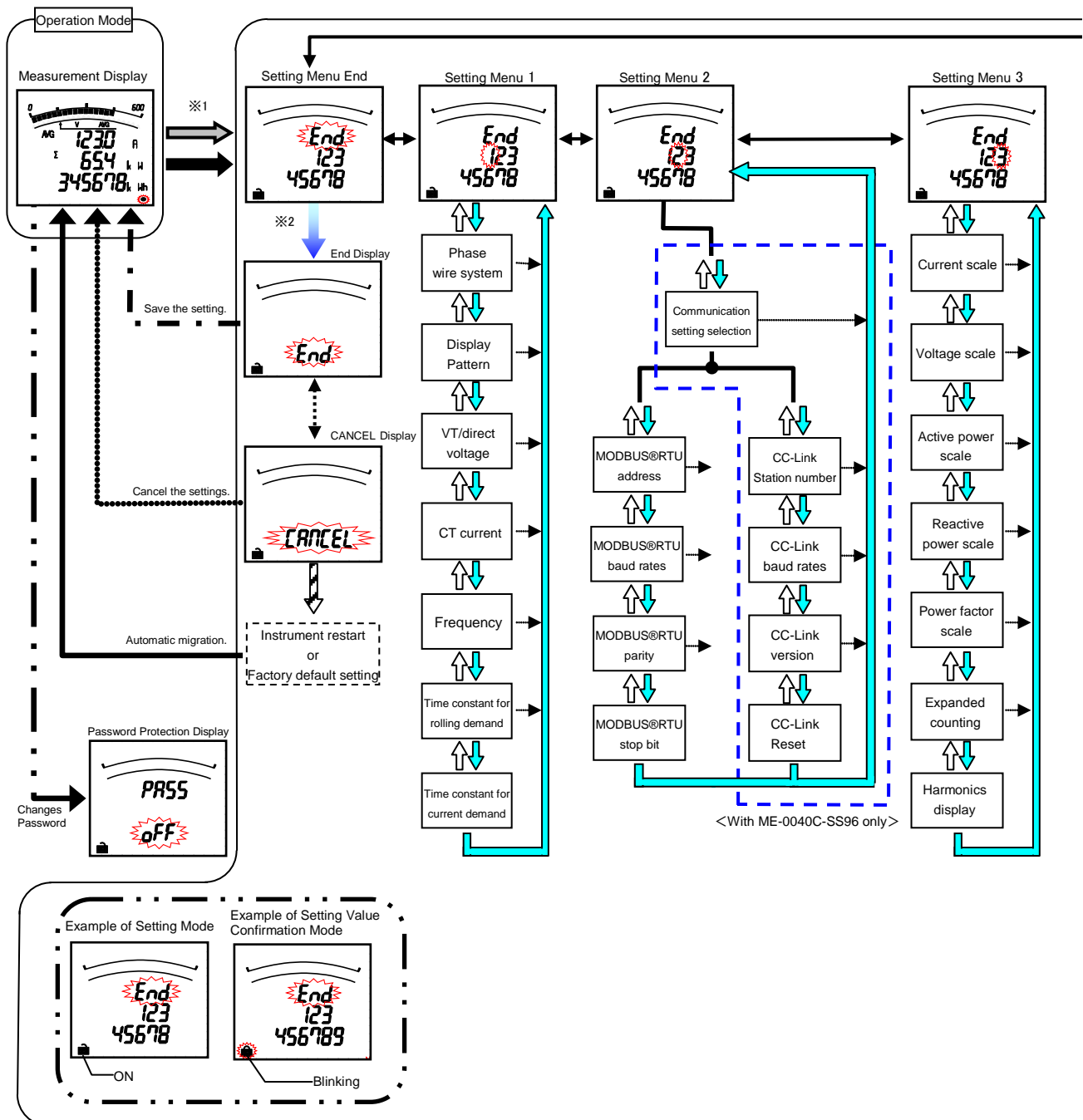

**CAUTION** Keep in mind that when a setting is changed, the related setting items and measurement data will be reset to the default settings. (Refer to page 51.)

### 3. Setting

#### 3.1. Setting flow

##### <Setting Procedure>

- ① Press (SET) and (RESET) simultaneously for 2 seconds to get in the setting mode.
- ② Select a setting menu number by (+) or (-).
- ③ Use the (SET) button to select a setting menu number.
- ④ Set each setting item. (Refer to page 22 and later pages.)
- ⑤ After completion of setting, select 'End' in the setting menu and press (SET).
- ⑥ When the End display appears, press (SET) once again.

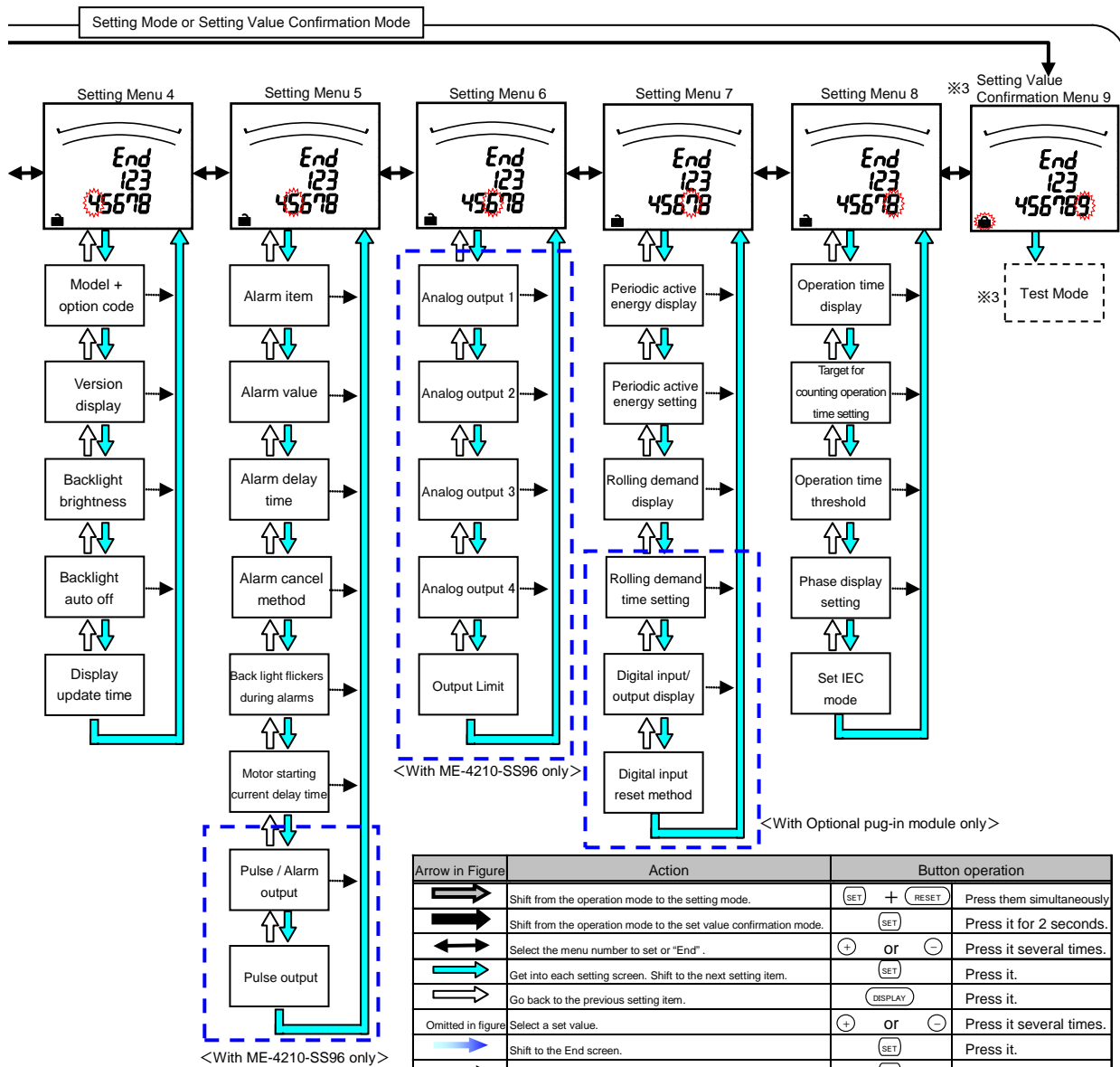

- ※1. If the password protection setting is enabled, it is necessary to enter the password in shift from the operation mode to the setting mode.
- ※2. For Setting Value Confirmation, it returns to Operation Mode.
- ※3. This is not display in Setting Mode.

Arrow in Figure	Action	Button operation
	Shift from the operation mode to the setting mode.	(SET) + (RESET) Press them simultaneously
	Shift from the operation mode to the set value confirmation mode.	(SET) Press it for 2 seconds.
	Select the menu number to set or "End".	(+) or (-) Press it several times.
	Get into each setting screen. Shift to the next setting item.	(SET) Press it.
	Go back to the previous setting item.	(DISPLAY) Press it.
Omitted in figure	Select a set value.	(+) or (-) Press it several times.
	Shift to the End screen.	(SET) Press it.
	Memorize the setting contents, and go back to the operation mode.	(SET) Press it.
	Select "CANCEL".	(+) or (-) Press it.
	Cancel the settings.	(SET) Press it.
	Skip remaining setting items during setting.	(SET) Press it for 1 second.
	Set values return to the factory default value.	(RESET) + (PHASE) Press it for 2 seconds.
	Shift from the operation mode to the password protection mode.	(RESET) + (PHASE) Press it for 2 seconds.

### 3. Setting

#### 3.1. Setting flow

■ Setting flow when with ME-0000MT-SS96

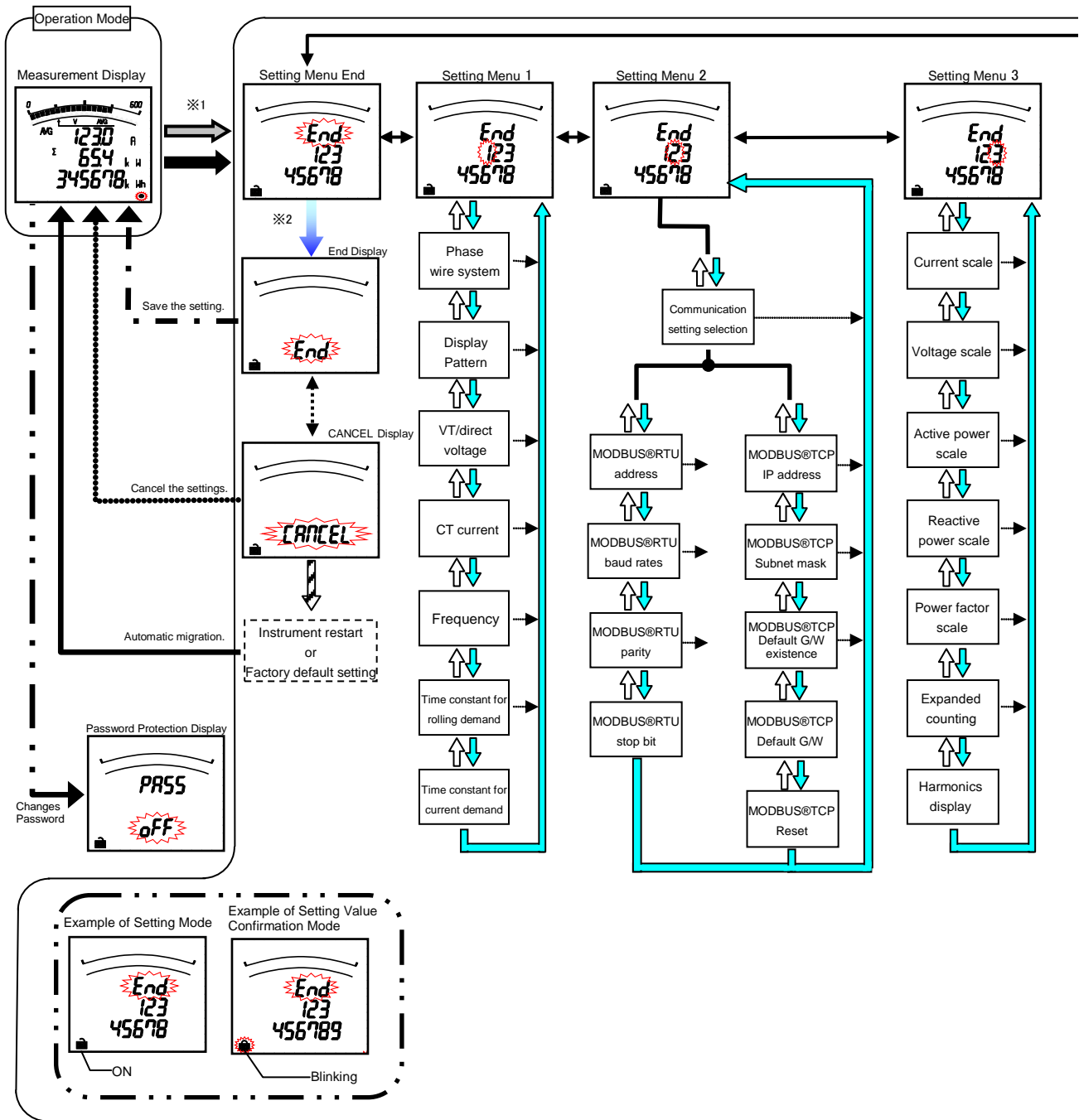

**CAUTION** Keep in mind that when a setting is changed, the related setting items and measurement data will be reset to the default settings. (Refer to page 51.)

### 3. Setting

#### 3.1. Setting flow

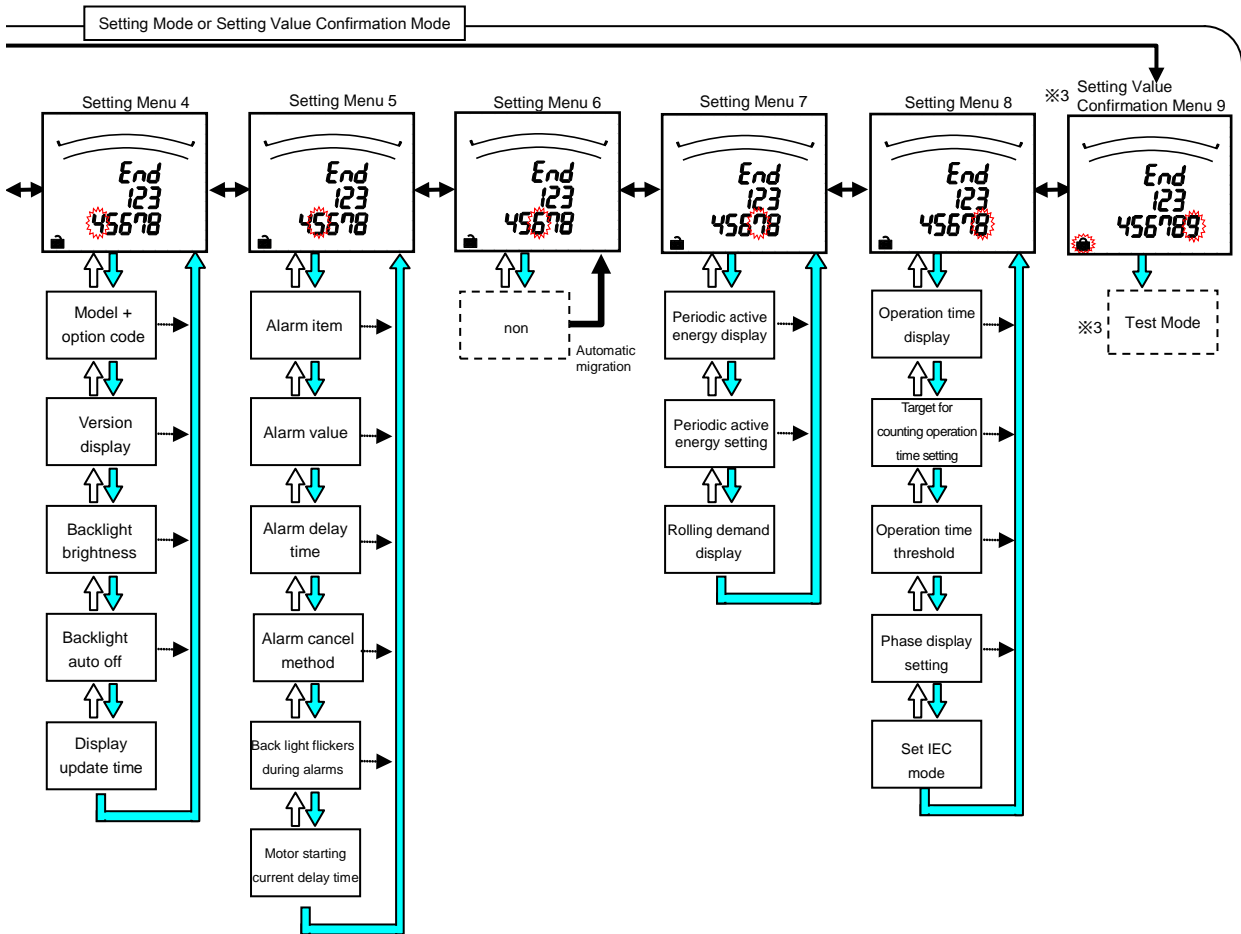

Arrow in Figure	Action	Button operation
	Shift from the operation mode to the setting mode.	(SET) + (RESET) Press them simultaneously
	Shift from the operation mode to the set value confirmation mode.	(SET) Press it for 2 seconds.
	Select the menu number to set or "End".	(+) or (-) Press it several times.
	Get into each setting screen. Shift to the next setting item.	(SET) Press it.
	Go back to the previous setting item.	(DISPLAY) Press it.
Omitted in figure	Select a set value.	(+) or (-) Press it several times.
	Shift to the End screen.	(SET) Press it.
	Memorize the setting contents, and go back to the operation mode.	(SET) Press it.
	Select "CANCEL."	(+) or (-) Press it.
	Cancel the settings.	(SET) Press it.
	Skip remaining setting items during setting.	(SET) Press it for 1 second.
	Set values return to the factory default value.	(RESET) + (PHASE) Press it for 2 seconds.
	Shift from the operation mode to the password protection mode.	(RESET) + (PHASE) Press it for 2 seconds.

※1. If the password protection setting is enabled, it is necessary to enter the password in shift from the operation mode to the setting mode.

※2. For Setting Value Confirmation, it returns to Operation Mode.

※3. This is not display in Setting Mode.

### 3. Setting

#### 3.1. Setting flow

■ Setting flow when with ME-0000BU-SS96

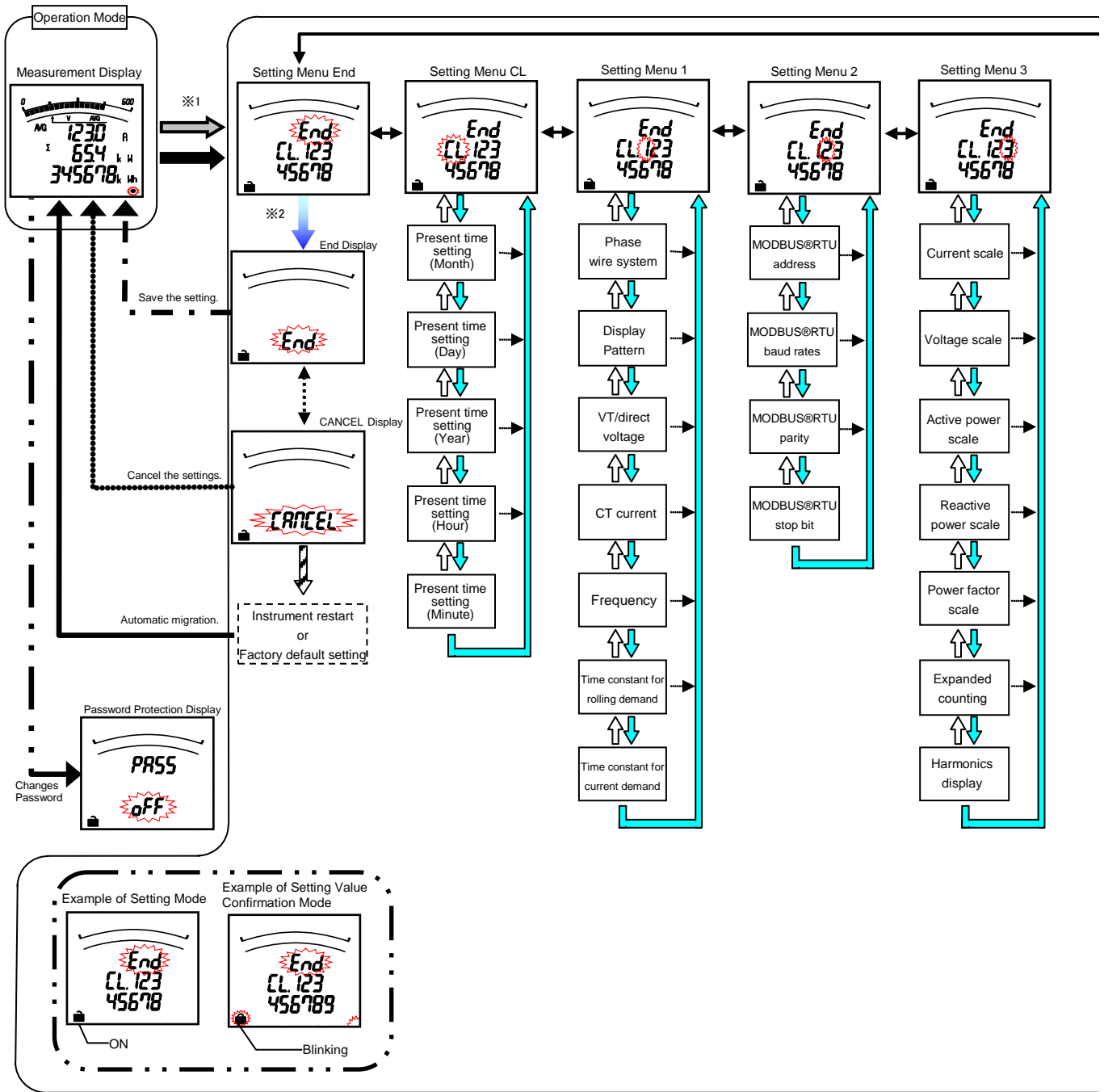

**CAUTION** Keep in mind that when a setting is changed, the related setting items and measurement data will be reset to the default settings. (Refer to page 51.)

### 3. Setting

#### 3.1. Setting flow

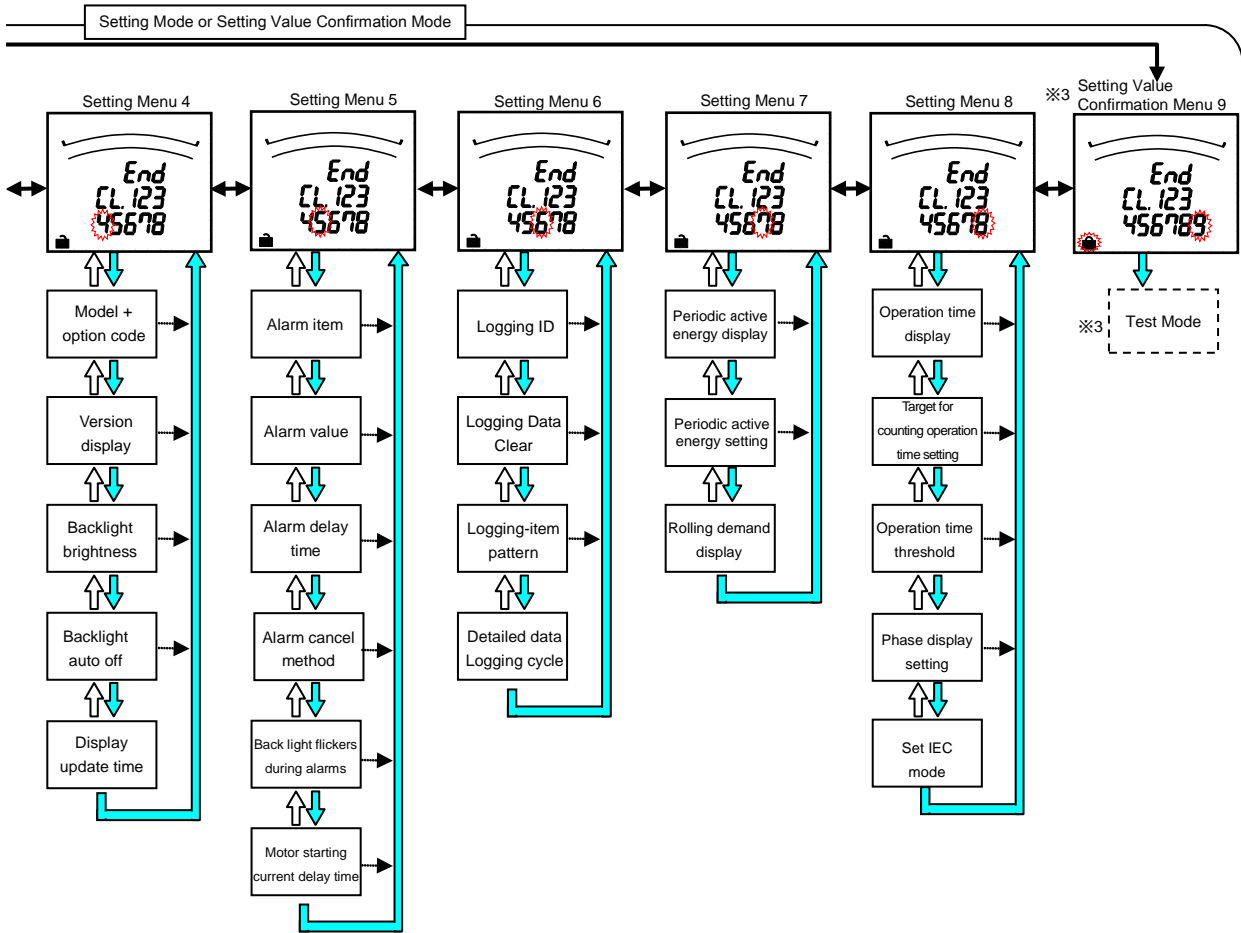

Arrow in Figure	Action	Button operation
	Shift from the operation mode to the setting mode.	(SET) + (RESET) Press them simultaneously
	Shift from the operation mode to the set value confirmation mode.	(SET) Press it for 2 seconds.
	Select the menu number to set or "End".	(+) or (-) Press it several times.
	Get into each setting screen. Shift to the next setting item.	(SET) Press it.
	Go back to the previous setting item.	(DISPLAY) Press it.
Omitted in figure	Select a set value.	(+) or (-) Press it several times.
	Shift to the End screen.	(SET) Press it.
	Memorize the setting contents, and go back to the operation mode.	(SET) Press it.
	Select "CANCEL".	(+) or (-) Press it.
	Cancel the settings.	(SET) Press it.
	Skip remaining setting items during setting.	(SET) Press it for 1 second.
	Set values return to the factory default value.	(RESET) + (PHASE) Press it for 2 seconds.
	Shift from the operation mode to the password protection mode.	(RESET) + (PHASE) Press it for 2 seconds.

※1. If the password protection setting is enabled, it is necessary to enter the password in shift from the operation mode to the setting mode.

※2. For Setting Value Confirmation, it returns to Operation Mode.

※3. This is not display in Setting Mode.

### 3. Setting

Basic Operations for setting

Function	Operation	Remarks
Select a set value	Press $\oplus$ or $\ominus$ .	Fast-forward when pressed over 1 sec.
Setting items are saved	Press $\text{SET}$ .	Setting item will be saved and shift to the next item.
Go back to the previous setting item	Press $\text{DISPLAY}$ .	The set value for the setting item just before Skip removing setting items returning is still available.
Skip removing setting items during setting	Press and hold $\text{SET}$ for 1 sec.	

### 3.2. Setting Menu 1: Basic Settings (Setting the Phase Wire System, Display Pattern, VT/Direct Voltage, CT Primary Current, etc.)

Set the phase wire method, display pattern, VT/direct voltage, CT primary current, etc.

In the operation mode, after pressing  $\text{SET}$  and  $\text{RESET}$  simultaneously for 2 seconds or more, the following operation becomes available.

Setting Menu

↑

①Phase Wire system

DISPLAY

↑

②Display Pattern

DISPLAY

↓

DISPLAY

↓

Set the setting menu number to "1".  
(as shown in the right figure)

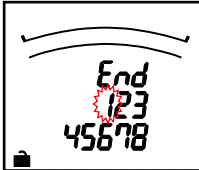

Set the phase wire system.

3P4 : 3-phase 4-wire  
 3P3. 2CT : 3-phase 3-wire (2CT)  
 3P3. 3CT : 3-phase 3-wire (3CT)  
 1P3. 1N2 : 1-phase 3-wire (1N2 display)  
 1P3. 1N3 : 1-phase 3-wire (1N3 display)  
 1P2 : 1-phase 2 -wire

Supplemental Information:  
Underlined portions indicate the default values.  
(Same from here.)

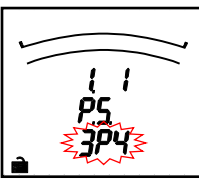

Set the display pattern.  
The following table shows the measurement elements that can be displayed by each display pattern. (For more details about display patterns, refer to page 77,78.)  
In addition, if there is no display pattern that you want from P01 to P13), select the special display pattern P00 to configure the screen freely.  
( For more information about setting the special display pattern P00, refer to page53,54)

○ : Displayable at this display setting.  
 △ : Set at other additional settings.  
 □ : Select "P00" and set the display order and display position.

(1)For 3-phase 4-wire

Display Pattern	Current	N Phase Current	Current Demand	N Phase Current Demand	Voltage	Active Power	Power Factor	Reactive Power	Apparent Power	Frequency	Active Energy (Imported)	Active Energy (Exported)	Reactive Energy (Imported LAG)	Apparent Energy	Active Energy (Imported)	Active Energy (Exported)	Reactive Energy (Special)	Apparent Energy	Periodic Active Energy	Rolling Demand	Harmonic Current/Voltage	Digital Input/ Output	Operation time
P01	○	○			○	○	○				○				○	△			△	△	△	△	△
P02	○	○			○	○	○												△	△	△	△	△
P03	○	○			○	○	○	○	○	○									△	△	△	△	△
P04	○	○			○	○	○	○	○	○	○	○	○	○	○	△	△	○	△	△	△	△	△
P05						○	○	○	○	○									△	△	△	△	△
P06	○	○			○														△	△	△	△	△
P07	○	○			○	○													△	△	△	△	△
P08	○	○			○	○					○				○	△			△	△	△	△	△
P09	○	○	○	○	○														△	△	△	△	△
P10	○	○	○	○	○	○													△	△	△	△	△
P11	○	○	○	○	○						○				○	△			△	△	△	△	△
P12	○	○	○	○	○	○					○				○	△			△	△	△	△	△
P13	○	○			○	○	○	○	○	○	○	○	○	○	○	△	△	○	△	△	△	△	△
P00	□	□	□	□	□	□	□	□	□	□	□	□	□	□	△	△	△	△	△	△	△	△	△

Note: The following settings are required for displaying elements on an additional display.

Measurement element on additional display	Setting item	Reference Pages
Active energy Exported /reactive energy Special(*)	Setting Menu 3 Active energy measurement	Page 32
Harmonic current/ Harmonic voltage	Setting Menu 3 Harmonics display	Page 32
Periodic Active Energy	Setting Menu 7 Periodic Active energy display	Page 44
Rolling Demand	Setting Menu 7 Rolling demand display	Page 44
Digital input / output status	Setting Menu 7 Digital input / output display	Page 45
Operation time	Setting Menu 8 Operation time display	Page 46

※When display elements does not set active energy/ reactive energy/ apparent energy, 'P00' of active energy/ reactive energy/ apparent energy on additional display does not appear.

### 3. Setting

#### 3.2 Setting menu 1: Basic Settings (Setting the Phase Wire System, Display Pattern, VT/Direct Voltage, CT Primary Current, etc.)

(2) For other phase wire system except 3-phase 4-wire

Display Pattern	Current	Current Demand	Voltage	Active Power	Power Factor	Reactive Power	Frequency	Active Energy(Imported)	Active Energy(Exported)	Reactive Energy y (Imported LAG)	Additional display										
											Active Energy (Imported)	Active Energy(Exported)	Reactive Energy (Special)	Periodic Active Energy	Rolling Demand	Harmonic Current/ Voltage	Digital Input/ Output	Operation time			
P01	<input type="checkbox"/>	<input type="checkbox"/>	<input type="checkbox"/>	<input type="checkbox"/>	<input type="checkbox"/>	<input type="checkbox"/>	<input type="checkbox"/>	<input type="checkbox"/>	<input type="checkbox"/>	<input type="checkbox"/>	<input type="checkbox"/>	<input type="checkbox"/>	<input type="checkbox"/>	<input type="checkbox"/>	<input type="checkbox"/>	<input type="checkbox"/>	<input type="checkbox"/>	<input type="checkbox"/>	<input type="checkbox"/>	<input type="checkbox"/>	<input type="checkbox"/>
P02	<input type="checkbox"/>	<input type="checkbox"/>	<input type="checkbox"/>	<input type="checkbox"/>	<input type="checkbox"/>	<input type="checkbox"/>	<input type="checkbox"/>	<input type="checkbox"/>	<input type="checkbox"/>	<input type="checkbox"/>	<input type="checkbox"/>	<input type="checkbox"/>	<input type="checkbox"/>	<input type="checkbox"/>	<input type="checkbox"/>	<input type="checkbox"/>	<input type="checkbox"/>	<input type="checkbox"/>	<input type="checkbox"/>	<input type="checkbox"/>	<input type="checkbox"/>
P03	<input type="checkbox"/>	<input type="checkbox"/>	<input type="checkbox"/>	<input type="checkbox"/>	<input type="checkbox"/>	<input type="checkbox"/>	<input type="checkbox"/>	<input type="checkbox"/>	<input type="checkbox"/>	<input type="checkbox"/>	<input type="checkbox"/>	<input type="checkbox"/>	<input type="checkbox"/>	<input type="checkbox"/>	<input type="checkbox"/>	<input type="checkbox"/>	<input type="checkbox"/>	<input type="checkbox"/>	<input type="checkbox"/>	<input type="checkbox"/>	<input type="checkbox"/>
P04	<input type="checkbox"/>	<input type="checkbox"/>	<input type="checkbox"/>	<input type="checkbox"/>	<input type="checkbox"/>	<input type="checkbox"/>	<input type="checkbox"/>	<input type="checkbox"/>	<input type="checkbox"/>	<input type="checkbox"/>	<input type="checkbox"/>	<input type="checkbox"/>	<input type="checkbox"/>	<input type="checkbox"/>	<input type="checkbox"/>	<input type="checkbox"/>	<input type="checkbox"/>	<input type="checkbox"/>	<input type="checkbox"/>	<input type="checkbox"/>	<input type="checkbox"/>
P05	<input type="checkbox"/>	<input type="checkbox"/>	<input type="checkbox"/>	<input type="checkbox"/>	<input type="checkbox"/>	<input type="checkbox"/>	<input type="checkbox"/>	<input type="checkbox"/>	<input type="checkbox"/>	<input type="checkbox"/>	<input type="checkbox"/>	<input type="checkbox"/>	<input type="checkbox"/>	<input type="checkbox"/>	<input type="checkbox"/>	<input type="checkbox"/>	<input type="checkbox"/>	<input type="checkbox"/>	<input type="checkbox"/>	<input type="checkbox"/>	<input type="checkbox"/>
P06	<input type="checkbox"/>	<input type="checkbox"/>	<input type="checkbox"/>	<input type="checkbox"/>	<input type="checkbox"/>	<input type="checkbox"/>	<input type="checkbox"/>	<input type="checkbox"/>	<input type="checkbox"/>	<input type="checkbox"/>	<input type="checkbox"/>	<input type="checkbox"/>	<input type="checkbox"/>	<input type="checkbox"/>	<input type="checkbox"/>	<input type="checkbox"/>	<input type="checkbox"/>	<input type="checkbox"/>	<input type="checkbox"/>	<input type="checkbox"/>	<input type="checkbox"/>
P07	<input type="checkbox"/>	<input type="checkbox"/>	<input type="checkbox"/>	<input type="checkbox"/>	<input type="checkbox"/>	<input type="checkbox"/>	<input type="checkbox"/>	<input type="checkbox"/>	<input type="checkbox"/>	<input type="checkbox"/>	<input type="checkbox"/>	<input type="checkbox"/>	<input type="checkbox"/>	<input type="checkbox"/>	<input type="checkbox"/>	<input type="checkbox"/>	<input type="checkbox"/>	<input type="checkbox"/>	<input type="checkbox"/>	<input type="checkbox"/>	<input type="checkbox"/>
P08	<input type="checkbox"/>	<input type="checkbox"/>	<input type="checkbox"/>	<input type="checkbox"/>	<input type="checkbox"/>	<input type="checkbox"/>	<input type="checkbox"/>	<input type="checkbox"/>	<input type="checkbox"/>	<input type="checkbox"/>	<input type="checkbox"/>	<input type="checkbox"/>	<input type="checkbox"/>	<input type="checkbox"/>	<input type="checkbox"/>	<input type="checkbox"/>	<input type="checkbox"/>	<input type="checkbox"/>	<input type="checkbox"/>	<input type="checkbox"/>	<input type="checkbox"/>
P09	<input type="checkbox"/>	<input type="checkbox"/>	<input type="checkbox"/>	<input type="checkbox"/>	<input type="checkbox"/>	<input type="checkbox"/>	<input type="checkbox"/>	<input type="checkbox"/>	<input type="checkbox"/>	<input type="checkbox"/>	<input type="checkbox"/>	<input type="checkbox"/>	<input type="checkbox"/>	<input type="checkbox"/>	<input type="checkbox"/>	<input type="checkbox"/>	<input type="checkbox"/>	<input type="checkbox"/>	<input type="checkbox"/>	<input type="checkbox"/>	<input type="checkbox"/>
P10	<input type="checkbox"/>	<input type="checkbox"/>	<input type="checkbox"/>	<input type="checkbox"/>	<input type="checkbox"/>	<input type="checkbox"/>	<input type="checkbox"/>	<input type="checkbox"/>	<input type="checkbox"/>	<input type="checkbox"/>	<input type="checkbox"/>	<input type="checkbox"/>	<input type="checkbox"/>	<input type="checkbox"/>	<input type="checkbox"/>	<input type="checkbox"/>	<input type="checkbox"/>	<input type="checkbox"/>	<input type="checkbox"/>	<input type="checkbox"/>	<input type="checkbox"/>
P11	<input type="checkbox"/>	<input type="checkbox"/>	<input type="checkbox"/>	<input type="checkbox"/>	<input type="checkbox"/>	<input type="checkbox"/>	<input type="checkbox"/>	<input type="checkbox"/>	<input type="checkbox"/>	<input type="checkbox"/>	<input type="checkbox"/>	<input type="checkbox"/>	<input type="checkbox"/>	<input type="checkbox"/>	<input type="checkbox"/>	<input type="checkbox"/>	<input type="checkbox"/>	<input type="checkbox"/>	<input type="checkbox"/>	<input type="checkbox"/>	<input type="checkbox"/>
P12	<input type="checkbox"/>	<input type="checkbox"/>	<input type="checkbox"/>	<input type="checkbox"/>	<input type="checkbox"/>	<input type="checkbox"/>	<input type="checkbox"/>	<input type="checkbox"/>	<input type="checkbox"/>	<input type="checkbox"/>	<input type="checkbox"/>	<input type="checkbox"/>	<input type="checkbox"/>	<input type="checkbox"/>	<input type="checkbox"/>	<input type="checkbox"/>	<input type="checkbox"/>	<input type="checkbox"/>	<input type="checkbox"/>	<input type="checkbox"/>	<input type="checkbox"/>
P13	<input type="checkbox"/>	<input type="checkbox"/>	<input type="checkbox"/>	<input type="checkbox"/>	<input type="checkbox"/>	<input type="checkbox"/>	<input type="checkbox"/>	<input type="checkbox"/>	<input type="checkbox"/>	<input type="checkbox"/>	<input type="checkbox"/>	<input type="checkbox"/>	<input type="checkbox"/>	<input type="checkbox"/>	<input type="checkbox"/>	<input type="checkbox"/>	<input type="checkbox"/>	<input type="checkbox"/>	<input type="checkbox"/>	<input type="checkbox"/>	<input type="checkbox"/>
P00	<input type="checkbox"/>	<input type="checkbox"/>	<input type="checkbox"/>	<input type="checkbox"/>	<input type="checkbox"/>	<input type="checkbox"/>	<input type="checkbox"/>	<input type="checkbox"/>	<input type="checkbox"/>	<input type="checkbox"/>	<input type="checkbox"/>	<input type="checkbox"/>	<input type="checkbox"/>	<input type="checkbox"/>	<input type="checkbox"/>	<input type="checkbox"/>	<input type="checkbox"/>	<input type="checkbox"/>	<input type="checkbox"/>	<input type="checkbox"/>	<input type="checkbox"/>

Note: The following settings are required for displaying elements on an additional display.

Measurement element on additional display	Setting item	Reference Pages
Active energy Exported /reactive energy Special(*)	Setting Menu 3 Active energy measurement	Page 32
Harmonic current/ Harmonic voltage	Setting Menu 3 Harmonics display	Page 32
Periodic Active Energy	Setting Menu 7 Periodic Active energy display	Page 44
Rolling Demand	Setting Menu 7 Rolling demand display	Page 44
Digital input / output status	Setting Menu 7 Digital input / output display	Page 45
Operation time	Setting Menu 8 Operation time display	Page 46

※When display elements does not set active energy/ reactive energy, 'P00' of active energy/ reactive energy on additional display does not appear.

#### Set the VT

When direct input (without VT) ⇒ Select no, and then press **SET**, shift to following (1).

When using VT ⇒ Select yES, and then press **SET**, shift to following (2)

1. For 3-phase 4-wire

no ↔ yES

2. For 3-phase 3-wire or 1-phase 2-wire

yES ↔ no

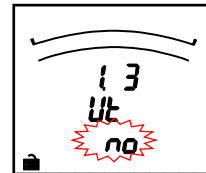

<When ①phase wire system is set to 1-phase 3-wire>  
Use only for direct input. This setting will be skipped.

Note. VT is voltage transformers.

#### ③VT / direct voltage

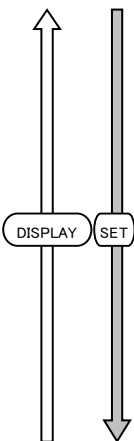

(1) For direct input (without VT) Set the direct voltage.

(a) For 3-phase 4-wire

(phase to neutral voltage / phase to phase voltage)

63.5/110V ↔ 100/173V ↔ 110/190V ↔ 220/380V ↔ 230/400V ↔ 240/415V  
↕  
277/480V ↔ 254/440V

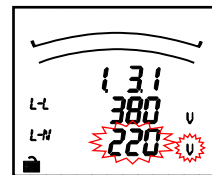

(b) For 3-phase 3-wire (2CT, 3CT) or 1-phase 2-wire

110V ↔ 220V ↔ 440V

(c) For 1-phase 3-wire (1N2, 1N3) (phase to neutral voltage / phase to phase voltage)

110/220V ↔ 220/440V



### 3. Setting

#### 3.2 Setting menu 1: Basic Settings (Setting the Phase Wire System, Display Pattern, VT/Direct Voltage, CT Primary Current, etc.)

Continued form the previous page

(2) When using VT

<Set the secondary and primary voltages of the VT.>

(a) For 3-phase 4-wire(Phase to phase Voltage)

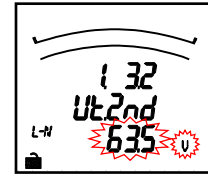
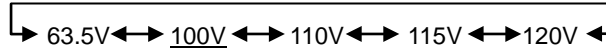

(b) For 3-phase 3-wire (2CT, 3CT) or 1-phase 2-wire(phase to neutral voltage)

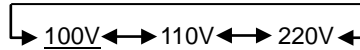

<Primary Voltage Settings>

Default value

For 3-phase 4-wire : 200V(Phase to phase Voltage)

For 3-phase 3-wire or 1-phase 2-wire: 10000V  
(phase to neutral voltage)

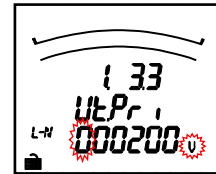

- From top digit, select the value of the flickering digit by (+) and (-)
- The setting digit can be moved to right by (SET)
- The setting digit can be moved to left by (DISPLAY)
- Setting is available in range from 60V to 750000V
  - Less than 100V : Upper 2 digits setting
  - Over 100V : Upper 3 digits setting
- ※Error display (E05) appears when set out of 60V to 750000V range.  
After that, please press (SET) review the setting value and set it once Again.
- ※When over 100V set over upper 3 digits setting, the display appear switching upper 3 digits setting.
- Press (SET) at the lowest digit, the setting step will shift to the next one.

Set the CT.

Primary / secondary Current Setting

<Set the secondary current>



Note. CT is current transformers.

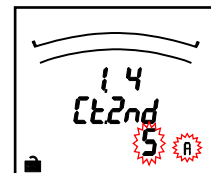

<Set the primary current>

Default Setting : 5.0A



- From top digit, select the value of the flickering digit by (+) and (-)
- The setting digit can be moved to right by the (SET).
- The setting digit can be moved to left by the (DISPLAY).
- Setting is available in range from 1.0A to 30000.0A
  - Less than 10A : Upper 2 digits setting
  - Over 10A : Upper 3 digits setting
- ※Error display (E05) appears when set out of 1.0 to 30000.0A range. After that, please press (SET), review the setting value and set it once again.
- ※When over 10A set over upper 3 digits setting, the display appear switching upper 3 digits setting.
- Press (SET) at the lowest digit, the setting step will shift to the next one.

④CT current

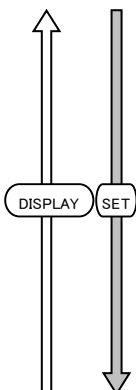

### 3. Setting

#### 3.2 Setting menu 1: Basic Settings (Setting the Phase Wire System, Display Pattern, VT/Direct Voltage, CT Primary Current, etc.)

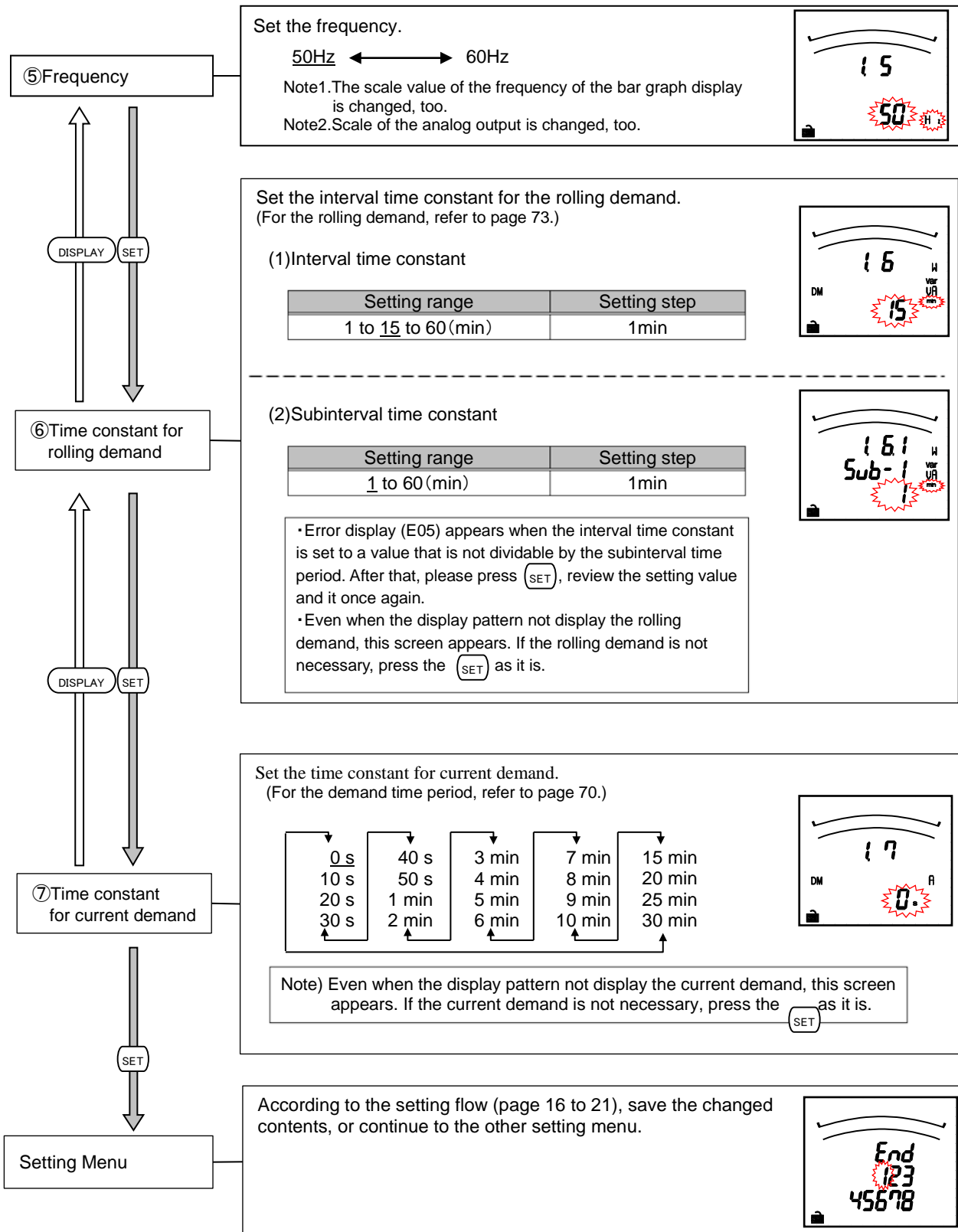

In the case of use only by the Setting menu 1, please go to “5. Operation” (from page 63).  
In the case to use additional functions, please go to “Setting Menus 2 - 8” (from page 26).

<b>Note</b>	<p>If the contents in the setting menu 1 are changed, the maximum value, minimum value, demand value of related measurement items will be reset. (However, active energy, reactive energy and Apparent energy will not be reset.) For detail, refer to section 3.15.</p>
-------------	--

### 3. Setting

#### 3.3. Setting Menu 2: Communication Settings (Setting the MODBUS<sup>®</sup>RTU communication)

<Setting flow when without optional plug-in module, with ME-4210-SS96, with ME-0052-SS96 or with ME-0000BU-SS96>

In the operation mode, press **SET** + **RESET** simultaneously for 2 seconds or more, and the following operation becomes available.

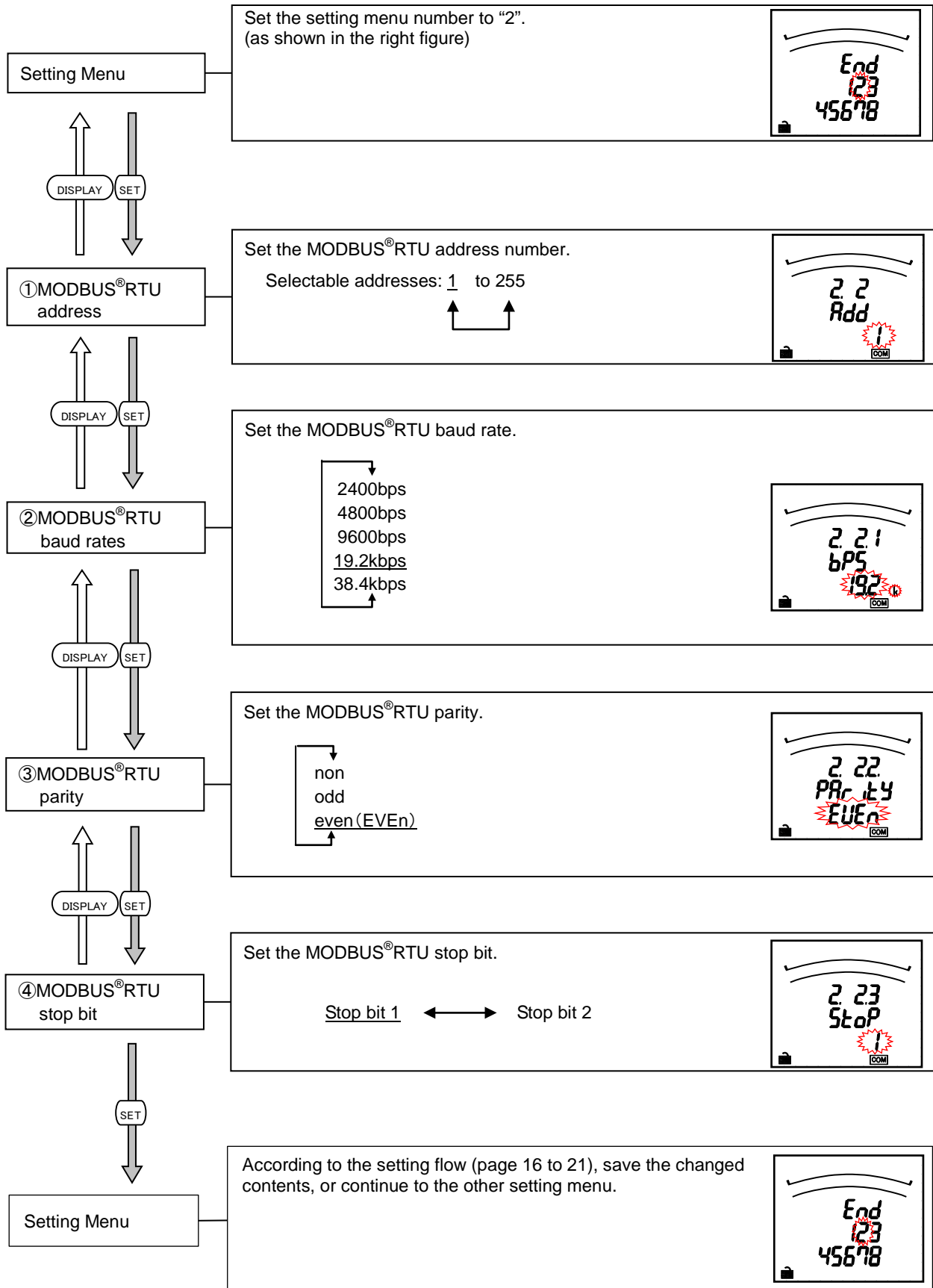

### 3. Setting

#### 3.4. Setting Menu 2: Communication Settings (Setting the CC-Link communication)

<Setting flow when with ME-0040C-SS96>

In the operation mode, press (SET) + (RESET) simultaneously for 2 seconds or more, and the following operation becomes available.

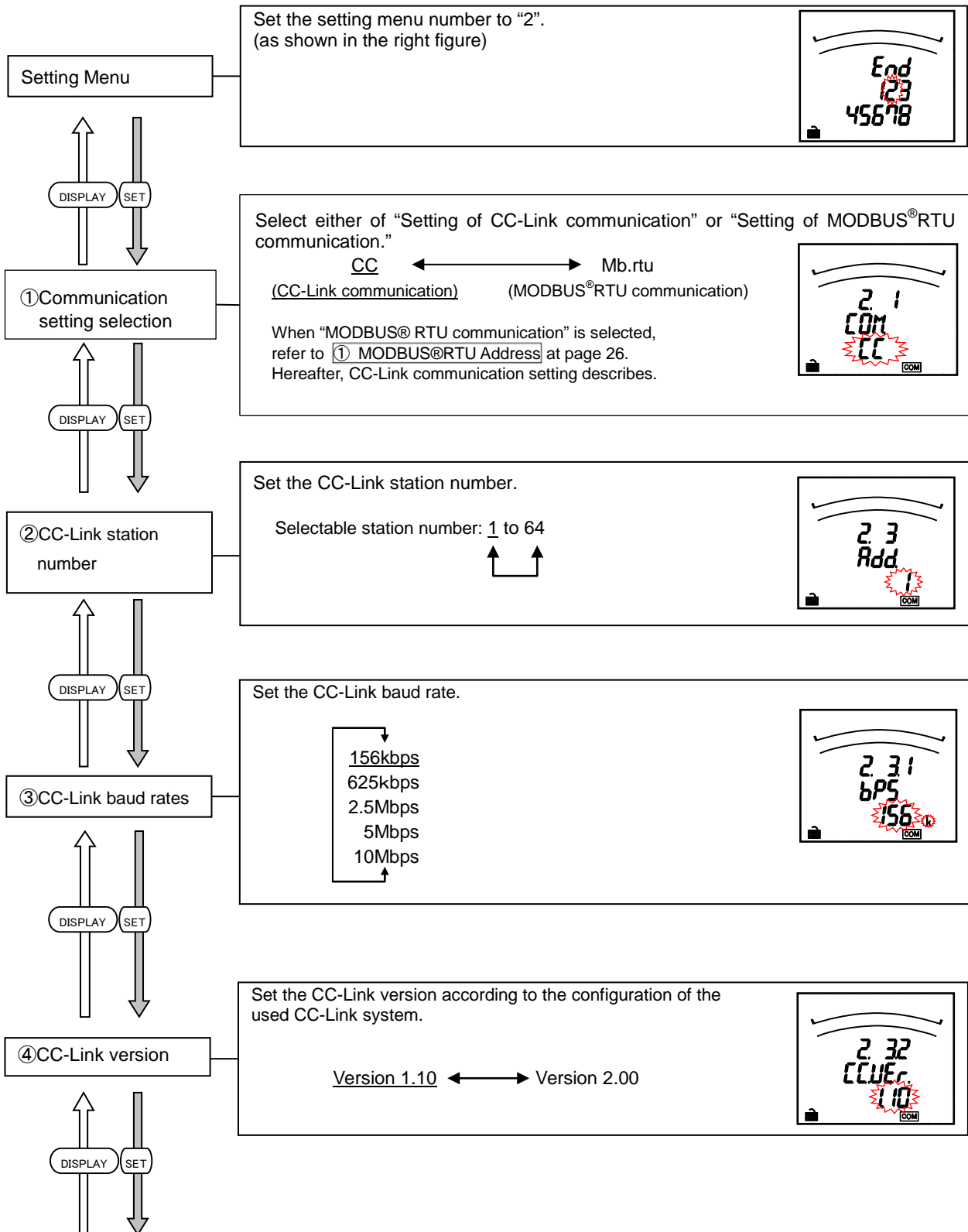

### 3. Setting

#### 3.4. Setting Menu 2: Communication Settings (Setting the CC-Link communication)

⑤Communication  
reset

When the changed above settings are enabled, set to "on."  
(When it is not set to "on," the changed settings of CC-Link do not become effective.)

oFF ←→ on

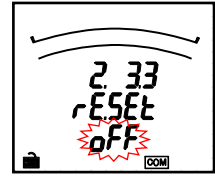

SET

Setting Menu

According to the setting flow (page 16 to 21), save the changed contents, or continue to the other setting menu.

If it is needed to set the MODBUS®RTU communication setting,  
Select the menu number "2" again, and select "Mb.rtu" at  
①Communication setting selection.

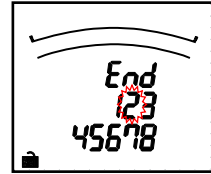

### 3. Setting

#### 3.5. Setting Menu 2: Communication Settings (Setting the MODBUS<sup>®</sup>TCP communication)

<Setting flow when with ME-0000MT-SS96>

In the operation mode, press **SET** + **RESET** simultaneously for 2 seconds or more, and the following operation becomes available.

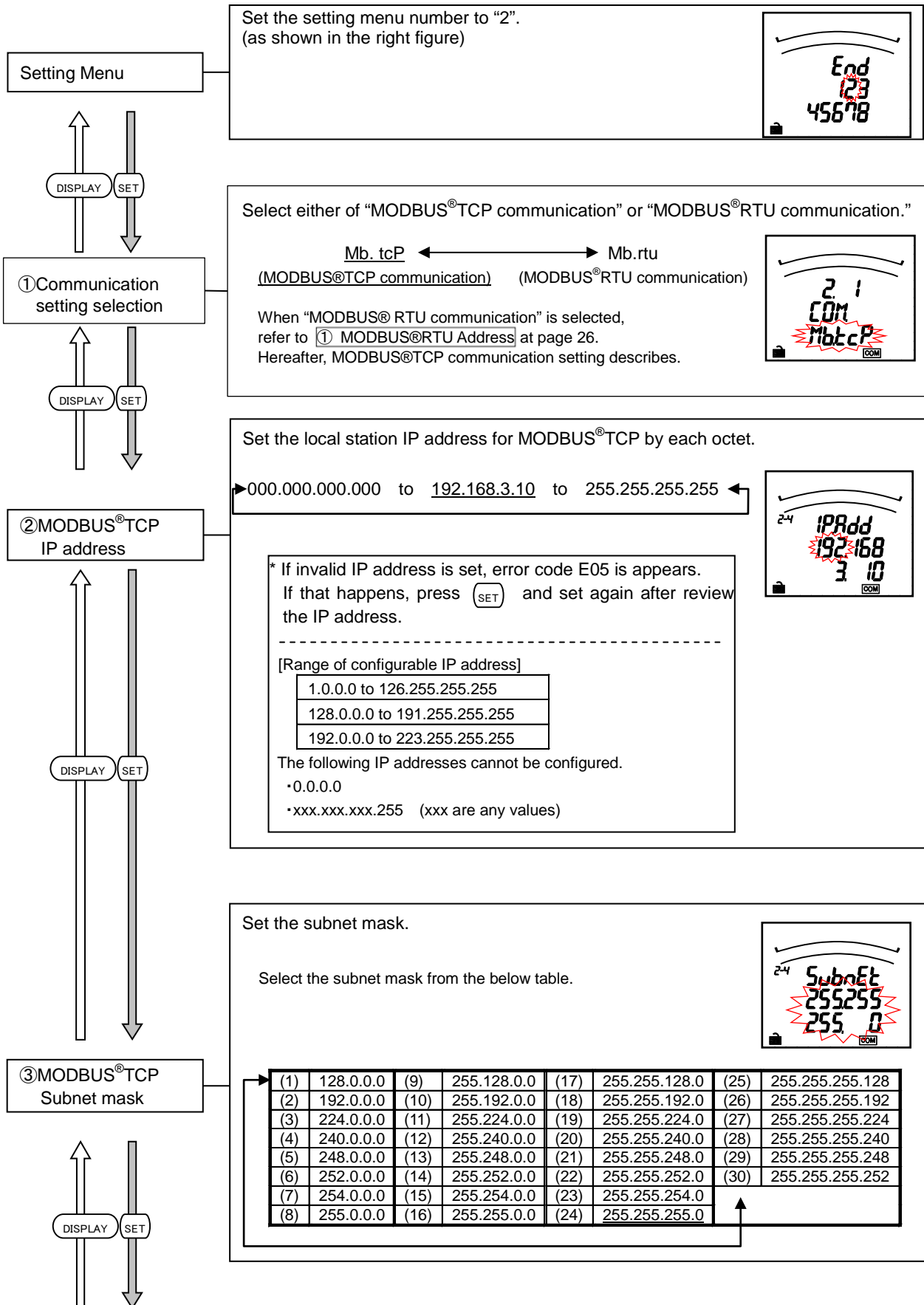

### 3. Setting

#### 3.5. Setting Menu 2: Communication Settings (Setting the MODBUS®TCP communication)

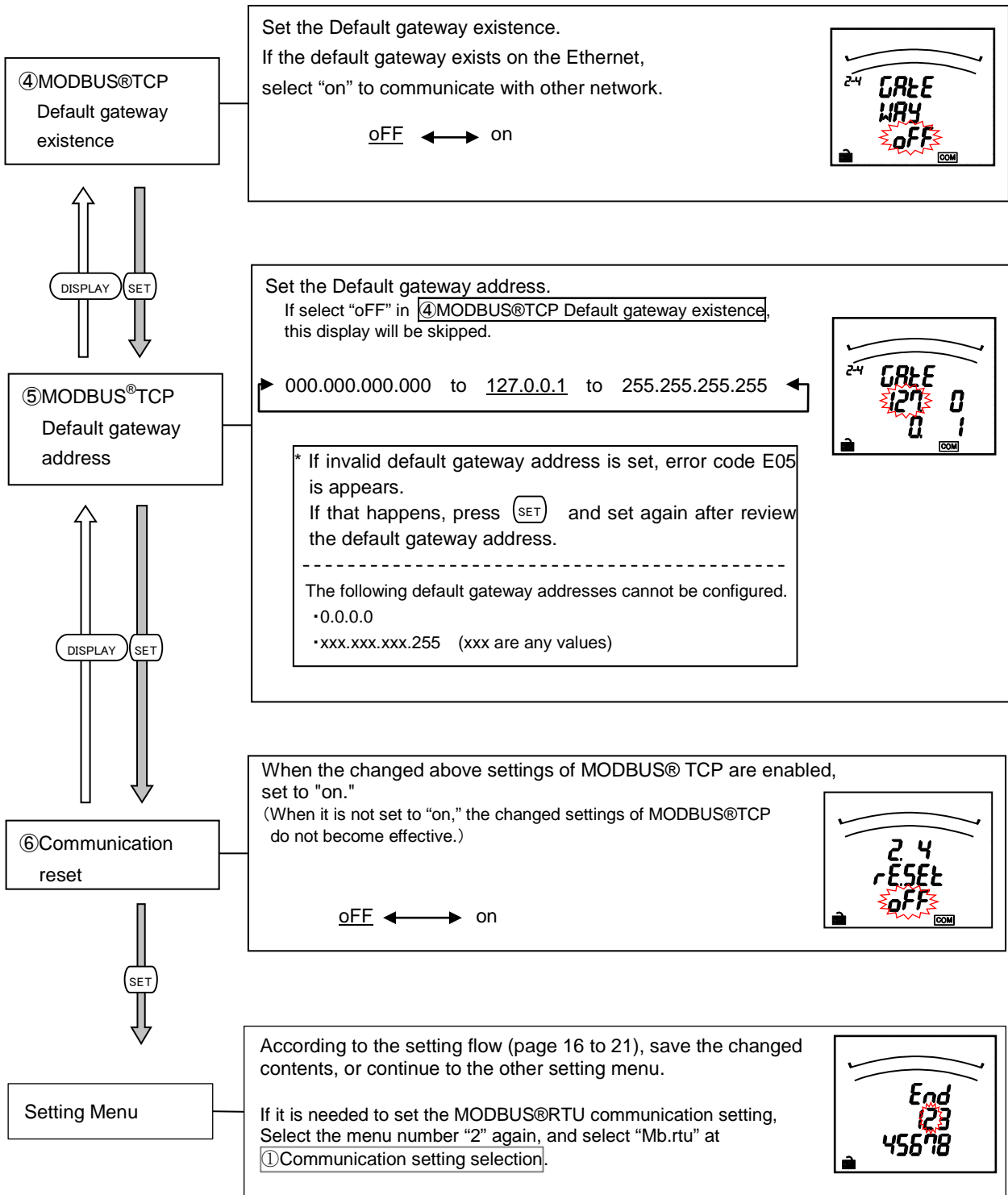

### 3. Setting

#### 3.6. Setting Menu 3: Display Settings (Setting Maximum Scale, Active Energy Measurement, and Harmonic Display, etc.)

This section shows how to set maximum scale in the bar graph, expanded counting, and harmonics display. In the operation mode, press **(SET)** and **(RESET)** simultaneously for 2 seconds or more, and the following operation becomes available.

Setting menu

↑

DISPLAY

↓

SET

Set the setting menu number to "3".  
(as shown in the right figure)

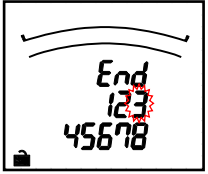

① Current maximum scale

↑

DISPLAY

↓

SET

Set the current maximum scale.  
If you have not set current to "Display pattern", this display menu will be skipped.

(1) Maximum scale value

Primary Current  
(1.4.1 Primary Current Setting value) SP.(Special Setting)

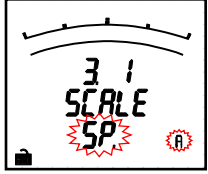

---

(2) Special current maximum scale  
This display is displayed when you set the "SP" in 3.1.

+ 3 STEP (About 120%)  
to  
± 0 STEP (100% : Rating)  
to  
-10 STEP (About 40%)

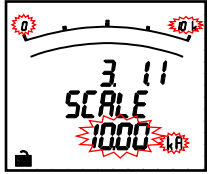

Note: The maximum scale value becomes the value in the table on Section 6.3.(page 80 and after).

② Voltage maximum scale

↑

DISPLAY

↓

SET

Set the voltage maximum scale.  
If you have not set voltage to "Display pattern", this display menu will be skipped.

Maximum scale value

+10 STEP (About 250%)  
to  
± 0 STEP (100% : Standard maximum scale value)  
to  
-18 STEP (About 20%)

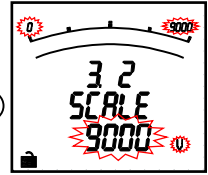

Note: The maximum scale value becomes the value in the table on Section 6.3.(page 80 and after).

③ Active power maximum scale

↑

DISPLAY

↓

SET

Set the maximum scale of Active power, Rolling demand.  
If you have not set active power and rolling demand to "Display pattern", this display will be skipped. And, if selected not Active power but rolling demand, "(2)single deflection/ double deflection" will be skipped.

(1) Maximum scale value

+3 STEP (About 120%)  
to  
± 0 STEP (100% : Rating)  
to  
-18 STEP (About 20%)

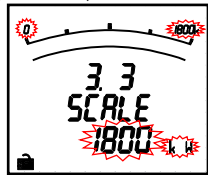

Note: The maximum scale value becomes the value in the table on Section 6.3.(page 80 and after).

(2) single deflection / double deflection

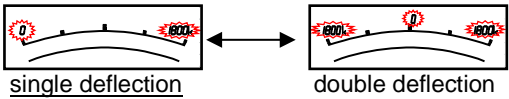
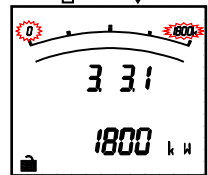
④ Reactive power maximum scale

↑

DISPLAY

↓

SET

Set the maximum scale of Reactive power.  
If you have not set reactive power to "Display pattern", this display will be skipped.

The setting method is the same as ③ active power maximum scale.  
Reactive power is only "double deflection".

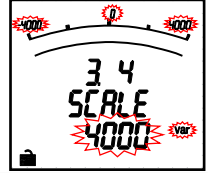



### 3. Setting

#### 3.6. Setting Menu 3: Display Settings (Setting Maximum Scale, Active Energy Measurement, and Harmonic Display, etc.)

⑤ Power factor scale

DISPLAY

SET

Set the power factor scale.  
If you have not set power factor to "Display pattern", this display will be skipped.

-0.5 to 1 to 0.5 ←→ -0 to 1 to 0

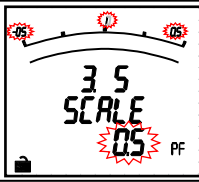

⑥ Expanded counting

DISPLAY

SET

Set the combinations of imported / exported and lag / lead for active energy and reactive energy you want to display, and set the measurement method for reactive energy.

Combination (Setting value)	Display						Reactive energy measurement method
	Wh		varh				
	Imported	Exported	Imported		Exported		
			lag	lead	lag	lead	
I	○		○				2 quadrant measurement
II	○		○	○			
III	○	○	○			○	4 quadrant measurement
IV	○	○	○	○	○	○	

Note: For more information about the measurement method for reactive energy, refer to page 69.

Combination I, II ⇒ It is suitable for the counting of equipment without the private electric generator and the reactive power of the capacitor load at the power factor = 0, generally.

Combination III, IV ⇒ It is suitable for the counting of equipment with the private electric generator.

< Example Screen >

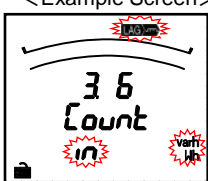
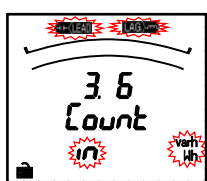
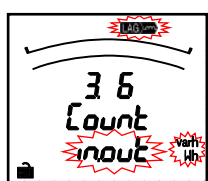
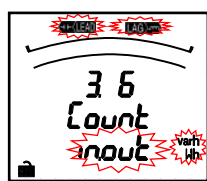
in :Imported out :Exported LEAD :lead varh LAG :lag varh

Depending on the above combination and the measurement element which set in ② Display pattern of the setting menu 1, the energies displayed at the additional screen are as below.

	Additional Screen			
Wh	Wh	-Wh	—	—
-Wh	—	—	—	—
varh	varh	varh(imported LEAD)	varh(exported LAG)	varh(exported LEAD)
VAh	VAh	—	—	—

Note: Wh:Wh(imported), -Wh:Wh(exported), varh:varh(imported LAG)

⑦ Harmonics

DISPLAY

SET

Set "on or off" of the harmonic measurement display.

oFF ←→ on  
(Not displayed) (Displayed)

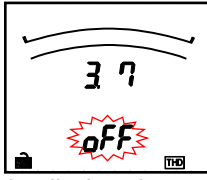

When the display is set to "on," the harmonic measured value can be displayed on an additional screen of the display pattern.

Setting Menu

SET

According to the setting flow (page 16 to 21), save the changed contents, or continue to the other setting menu.

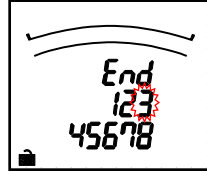

#### Note

- Accuracy is defined to rated current. Although the maximum scale may display 120% or more of rated current and rated voltage in order to make a scale easy to read depending on the settings of VT/direct voltage and CT primary current, current input is within 100% of rated current.
- Even if a display pattern is selected that cannot display active power, reactive power, active energy, and reactive energy, it is possible to display the sign according to 2 quadrant / 4 quadrant measurement of the power factor and reactive power due to ⑥ Expanded counting, so setting items for ⑥ Expanded counting will be displayed.

### 3. Setting

#### 3.7. Setting Menu 4: LCD Settings (Setting Model Display, Version Display, Backlight, and Display Update Time)

This section is for confirming the model, option code and the product version, and also set the backlight and the display update time. In the operation mode, press (SET) + (RESET) simultaneously for 2 seconds or more, and the following operation becomes available.

Setting menu

↑

↓

① Model + option code

↑

↓

② Version display

↑

↓

③ Backlight brightness

↑

↓

④ Backlight auto off

↑

↓

⑤ Display update time

↑

↓

Setting Menu

↓

Set the setting menu number to "4".  
(as shown in the right figure)

The model can be confirmed. (This is only display, and settings cannot be changed.)

(1) Middle Line

Model	
<b>SSrAmB</b>	ME96SSRA-MB

(2) Lower Line

Option code	
Blank	
42 10	ME-4210-SS96
0040C	ME-0040C-SS96
0052	ME-0052-SS96
ME	ME-0000MT-SS96
0000BU	ME-0000BU-SS96

\*1 If "E90xx" appears, MODBUS@TCP communication error will be occurred.

The product version can be checked.  
(The product version is displayed, but cannot be changed.)

The backlight brightness can be adjusted.

1

↔

2

↔

3

↔

4

↔

5

Dark

Bright

The backlight can be set to continuous on (HoLd) or auto off (Auto).

Auto  
(Auto off)

↔

HoLd  
(Continuous on)

<When auto off (Auto) is selected>  
No button operation for 5 minutes → the backlight turns off  
Button operation during off (Note) → the backlight turns on for 5 minutes

Note: When the backlight is off, pressing any button once does not switch the display but only turns on the backlight. Pressing any button again switches the display.

The display update time for the measured value can be change.  
If the display switches too quickly for you to read the displayed value, set it to 1.0 second.  
(Normally, leave this setting to 0.5 second.)

0.5second

↔

1second

According to the setting flow (page 16 to 21), save the changed contents, or continue to the other setting menu.

### 3. Setting

#### 3.8. Setting Menu 5: Pulse and Alarm Settings (Setting Upper/Lower Limit Alarm, Motor Starting Current Mask Function, Pulse Output, etc.)

This section shows how to set the upper/lower limit alarm, backlight flickering during alarm, motor starting current delay time, and pulse output.

In the operation mode, press **SET** and **RESET** simultaneously for 2 seconds or more, and the following operation becomes available.

For more details about each function, refer to the corresponding pages.  
 Upper/lower limit alarm → Pages 71 and 72, Motor startup current → Page 75

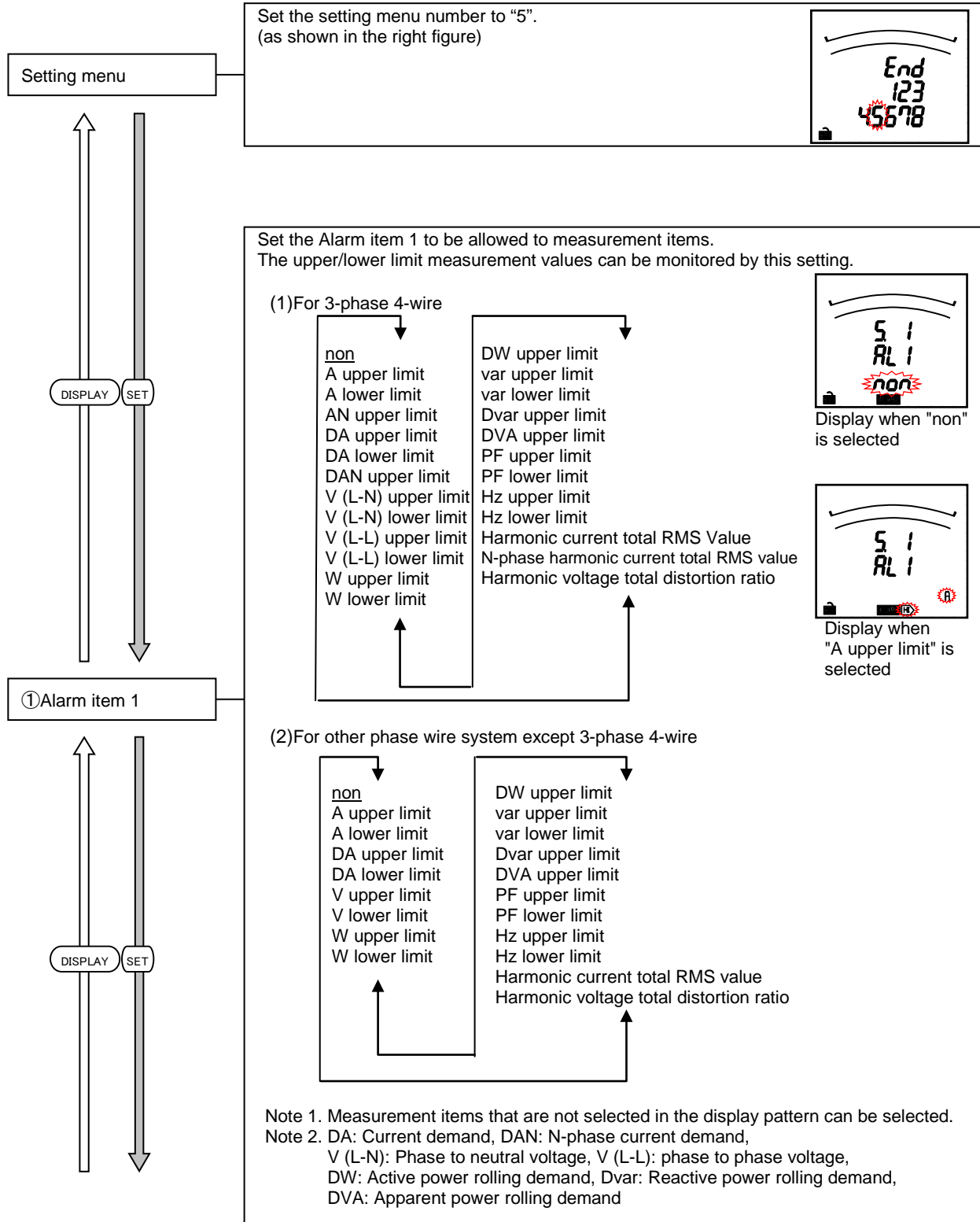

### 3. Setting

#### 3.8. Setting Menu 5: Pulse and Alarm Settings (Setting Upper/Lower Limit Alarm, Motor Starting Current Mask Function, Pulse Output, etc.)

Set the alarm value for upper/lower limit alarm element 1. The following table shows the setting range.

Measuring element	Setting range	Setting step(Note)
A, AN, DA, DAN upper limit	5 to <u>100</u> to 120(%)	1%
A, DA lower limit	3 to <u>10</u> to 95(%)	1%
V (L-N), V (L-L) upper limit	25 to <u>110</u> to 135(%)	1%
V (L-N), V (L-L) lower limit	20 to <u>70</u> to 95(%)	1%
W, var upper limit	-95 to <u>100</u> to 120(%)	1%
W, var lower limit	-120 to <u>3</u> to 95(%)	1%
DW, Dvar, DVA upper limit	5 to <u>100</u> to 120(%)	1%
PF upper limit	-0.05 to <u>1</u> to 0.05	0.05
PF lower limit	-0.05 to <u>-0.5</u> to 0.05	0.05
Hz upper limit	45 to <u>65</u> (Hz)	1Hz
Hz lower limit	<u>45</u> to 65(Hz)	1Hz
Harmonic current total RMS value	1 to <u>35</u> to 120(%)	1%
N-phase harmonic current total RMS value	1 to <u>35</u> to 120(%)	1%
Harmonic voltage total distortion ratio	0.5 to <u>3.5</u> to 20.0(%)	0.5%

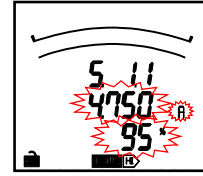

Note: W, var, DW, Dvar, DVA and var show the percentage for the maximum scale value (±0 step).

A, AN, DA, DAN, Harmonic current total RMS value, N-phase harmonic current total RMS value shows the percentage for the CT primary current.

"V" shows the percentage for the VT primary voltage (or direct voltage).

(The "V" for 1-phase 3-wire is the percentage for phase to neutral voltage.)

Alarm monitoring is executed using twice the value which set upper/lower limit alarm for the 12-phase and 13-phase.)

②Alarm value 1

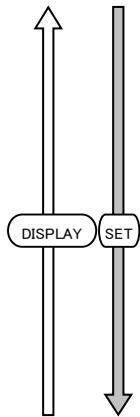

Set the measurement element assigned to the upper/lower limit alarm items 2 to 4. Elements that are set elsewhere cannot be set.

The setting method is the same as ①Alarm item 1 .

③Alarm item 2 to 4

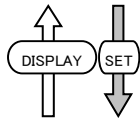

Set the alarm value for the upper/lower limit alarm items 2 to 4.

The setting method is the same as ②Alarm value 1 .

④Alarm value 2 to 4

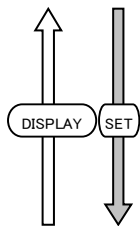

Set the alarm mask time for when you want to prevent a momentary overload or noise alarm.

When this is set, an alarm is generated only when the alarm value over the upper/lower limit alarm value for a longer time than the delay time. On the setting screen, seconds are indicated by "s" and minutes are indicated by "min".

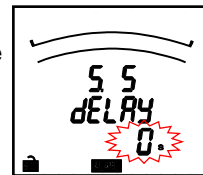

0s	30s	2min
5s	40s	3min
10s	50s	4min
20s	1min	5min

Note:

When all settings for ①Alarm item 1 and ③Alarm item 2 to 4 are set to "non", this setting will be skipped.

⑤Alarm delay time

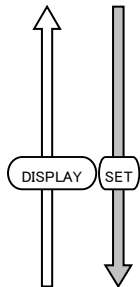

Set the alarm cancel method at generation of alarm. (screen, relay)

Reset method (Setting value)	Description (Refer to pages 71 and 72)
Automatic (Auto)	When there is no alarm generation condition, alarm is automatically reset.
Manual (HoLd)	The alarm will continue even when the alarm generated conditions no longer exist. It is necessary to execute button operation to cancel the alarm.



Note: When all settings for ①Alarm item 1 and ③Alarm item 2 to 4 are set to "non", this setting will be skipped.

⑥Alarm cancel method

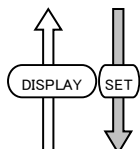

### 3. Setting

#### 3.8. Setting Menu 5: Pulse and Alarm Settings (Setting Upper/Lower Limit Alarm, Motor Starting Current Mask Function, Pulse Output, etc.)

⑦ Backlight flickers during alarms

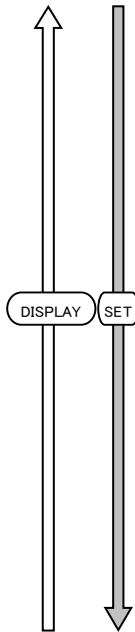

It is possible to make the backlight to flicker when an alarm is generated.

oFF ← → on  
(Not flicker) (Flicker)

Note: When all settings for ① Alarm item 1 and ③ Alarm item 2 to 4 are set to "non," this setting will be skipped.

⑧ Motor starting current delay time

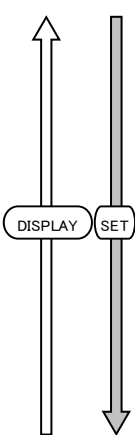

By using this setting for motor current monitoring delay time, it is possible to prevent unnecessary maximum value updating and unnecessary alarms caused by the motor startup current.

When this setting is not needed → Select "oFF" and press (SET) and return to the Setting Menu or go to menu 5.9(ME-4210-SS96)

When this setting is executed → Select "on" and press (SET), and go to (1) below.

oFF ← → on

---

(1) Motor starting current value.  
Set the value for detecting the motor starting current.

Setting range	Setting step (Note)
3 to <u>5</u> to 120 (%)	1%

\* This is the percentage for the maximum scale value for the current (±0 step).

(2) Motor starting current delay time  
After the motor starting current is detected, maximum value update is not executed and an alarm is not generated for the delay time.

1s	15s	1min	4min
3s	20s	1.5min	5min
5s	30s	2min	
<u>10s</u>	45s	3min	

### 3. Setting

#### 3.8. Setting Menu 5: Pulse and Alarm Settings (Setting Upper/Lower Limit Alarm, Motor Starting Current Mask Function, Pulse Output, etc.)

⑨ Pulse/Alarm output 1

↑  
 ↓

Set the output function of Pulse/Alarm output 1.

When the ME-4210-SS96 optional plug-in module is not installed, this display will be skipped. Please refer to page 57 for the correspondence between Alarm output and Alarm item.

PULSE ←
→ AL

(Pulse output)      (Alarm output)

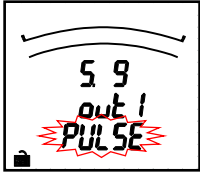

⑩ Pulse output 1 output item

↑  
 ↓

Set the item that is output to pulse output 1.

In the following cases, this display will be skipped.

- ME-4210-SS96 optional plug-in module is not installed.
- Not set "PULSE" to ⑨ Pulse/Alarm output 1.

Setting value	Display		
	Section (A)	Section (B)	Section (C)
Active energy (Imported)	8888	Wh	OFF
Active energy (Exported)	8888	Wh	OFF
Reactive energy (Imported, Lag)	8888	varh	LAG
Reactive energy (Imported, Lead)	8888	varh	←I-LEAD
Reactive energy (Exported, Lag)	8888	varh	LAG
Reactive energy (Exported, Lead)	8888	varh	←I-LEAD
Apparent energy	8888	VAh	OFF
Periodic active energy 1	Wh1	Wh	OFF
Periodic active energy 2	Wh2	Wh	OFF
non (No output)	non	OFF	OFF

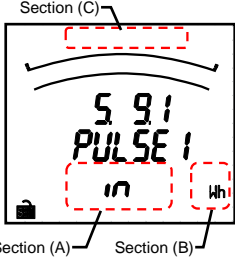

Note: The segment shown in the left table flickers according to the selected element.

⑪ Pulse output 1 pulse unit

↑  
 ↓

Set the pulse value of pulse output 1.

Pulse value is selected from the table below, according to total load power[kW].

In the following cases, this display will be skipped.

- ME-4210-SS96 optional plug-in module is not installed.
- Not set "PULSE" to ⑨ Pulse/Alarm output 1.
- Set "non" to ⑩ Pulse output 1 output item.

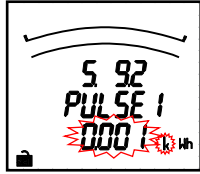

$$\text{Total load power[kW]} = \frac{\alpha \times (\text{VT primary voltage}) \times (\text{CT primary current})}{1000}$$

$\alpha$

:

1

1-phase 2-wire

2

1-phase 3-wire

$\sqrt{3}$

3-phase 3-wire

3

3-phase 4-wire

\*1: For 3-phase 4-wire setting, the VT primary voltage is calculated using the phase to neutral voltage.  
 \*2: For 1-phase 3-wire setting, the VT primary voltage is calculated using the phase to neutral voltage.  
 \*3: For direct voltage setting, the direct voltage is used for calculation instead of the VT primary voltage.

Total load [kW]	Possible pulse unit settings				
	1	0.1	0.01	0.001	
Less than 10	1	0.1	0.01	0.001	kWh/pulse
10 or higher but less than 100	10	1	0.1	0.01	
100 or higher but less than 1000	100	10	1	0.1	
1000 or higher but less than 10000	1	0.1	0.01	0.001	MWh/pulse
10000 or higher but less than 100000	10	1	0.1	0.01	
100000 or higher	100	10	1	0.1	

Note 1: When ⑩ Pulse output 1 output item is set to "non", this setting will be skipped.  
 Note 2: The factory default setting values are minimum values for the pulse unit that can be set.  
 Note 3: For reactive power, kW in the above table needs to be read as kvar, kWh needs to be read as kvarh, and MWh needs to be read as Mvarh.  
 Note 4: For apparent power, kW in the above table needs to be read as kVA, kWh needs to be read as kVAh, and MWh needs to be read as MVAh.

### 3. Setting

#### 3.8. Setting Menu 5: Pulse and Alarm Settings (Setting Upper/Lower Limit Alarm, Motor Starting Current Mask Function, Pulse Output, etc.)

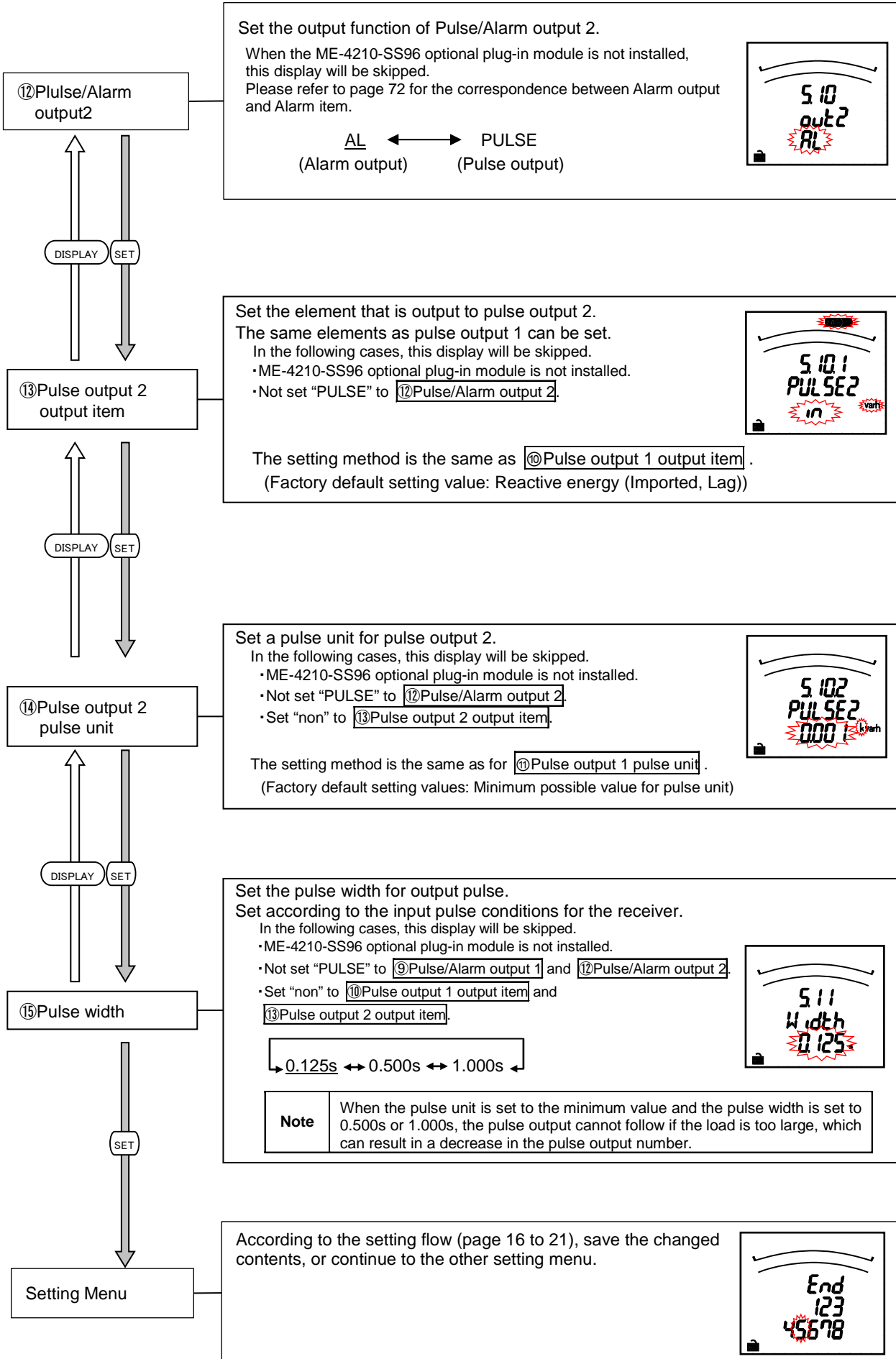

### 3. Setting

#### 3.9. Setting Menu 6: Setting the Analog Output

This section shows how to set analog output. When the ME-4210-SS96 optional plug-in module is not installed, this test menu will be skipped. In the operation mode, press (SET) and (RESET) simultaneously for 2 seconds or more, and the following operation becomes available.

Setting menu

↑

↓

DISPLAY SET

① Analog output CH1 output item

↑

↓

DISPLAY SET

Set the setting menu number to "6".  
(as shown in the right figure)

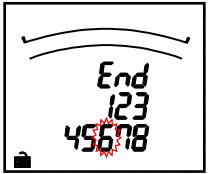

Set the measurement item to be output to analog output CH1.  
Select a measurement item for output from the following table.

(1) For 3-phase 4-wire

3-phase 4-wire		
non	V <sub>12</sub>	PF <sub>1</sub>
A <sub>1</sub>	V <sub>23</sub>	PF <sub>2</sub>
A <sub>2</sub>	V <sub>31</sub>	PF <sub>3</sub>
A <sub>3</sub>	V <sub>AVG(L-L)</sub>	<u>PF<sub>Σ</sub>(CH4)</u>
A <sub>N</sub>	W <sub>1</sub>	Hz
<u>A<sub>AVG</sub>(CH1)</u>	W <sub>2</sub>	Harmonic A <sub>1</sub>
Demand A <sub>1</sub>	W <sub>3</sub>	Harmonic A <sub>2</sub>
Demand A <sub>2</sub>	<u>W<sub>Σ</sub>(CH3)</u>	Harmonic A <sub>3</sub>
Demand A <sub>3</sub>	var <sub>1</sub>	Harmonic A <sub>N</sub>
Demand A <sub>N</sub>	var <sub>2</sub>	Harmonic V <sub>1N</sub>
Demand A <sub>AVG</sub>	var <sub>3</sub>	Harmonic V <sub>2N</sub>
V <sub>1N</sub>	var <sub>Σ</sub>	Harmonic V <sub>3N</sub>
V <sub>2N</sub>	VA <sub>1</sub>	
V <sub>3N</sub>	VA <sub>2</sub>	
<u>V<sub>AVG</sub>(L-N)(CH2)</u>	VA <sub>3</sub>	
	VA <sub>Σ</sub>	

AVG: Average, Σ: Total RMS Value

(2) For other phase wire system except 3-phase 4-wire

3-phase 3-wire	1-phase 3-wire (1N2 display)	1-phase 3-wire (1N3 display)	1-phase 2-wire
non	non	non	non
<u>A<sub>1</sub>(CH1)</u>	<u>A<sub>1</sub>(CH1)</u>	<u>A<sub>1</sub>(CH1)</u>	<u>A(CH1)</u>
A <sub>2</sub>	A <sub>N</sub>	A <sub>N</sub>	Demand A
A <sub>3</sub>	A <sub>2</sub>	A <sub>3</sub>	<u>V(CH2)</u>
A <sub>AVG</sub>	A <sub>AVG</sub>	A <sub>AVG</sub>	<u>W(CH3)</u>
Demand A <sub>1</sub>	Demand A <sub>1</sub>	Demand A <sub>1</sub>	var
Demand A <sub>2</sub>	Demand A <sub>N</sub>	Demand A <sub>N</sub>	VA
Demand A <sub>3</sub>	Demand A <sub>2</sub>	Demand A <sub>3</sub>	<u>PF(CH4)</u>
Demand A <sub>AVG</sub>	Demand A <sub>AVG</sub>	Demand A <sub>AVG</sub>	Hz
<u>V<sub>12</sub>(CH2)</u>	<u>V<sub>1N</sub>(CH2)</u>	<u>V<sub>1N</sub>(CH2)</u>	Harmonic A
V <sub>23</sub>	V <sub>2N</sub>	V <sub>3N</sub>	Harmonic V
V <sub>31</sub>	V <sub>12</sub>	V <sub>13</sub>	
V <sub>AVG</sub>	V <sub>AVG</sub>	V <sub>AVG</sub>	
<u>W(CH3)</u>	<u>W(CH3)</u>	<u>W(CH3)</u>	
var	var	var	
VA	VA	VA	
<u>PF(CH4)</u>	<u>PF(CH4)</u>	<u>PF(CH4)</u>	
Hz	Hz	Hz	
Harmonic A <sub>1</sub>	Harmonic A <sub>1</sub>	Harmonic A <sub>1</sub>	
Harmonic A <sub>3</sub>	Harmonic A <sub>2</sub>	Harmonic A <sub>3</sub>	
Harmonic V <sub>12</sub>	Harmonic V <sub>1N</sub>	Harmonic V <sub>1N</sub>	
Harmonic V <sub>23</sub>	Harmonic V <sub>2N</sub>	Harmonic V <sub>3N</sub>	

AVG: Average, Σ: Total RMS Value

Note 1: The same measurement item can be set for each analog output.  
 Note 2: It is possible to select measurement item that are not included in the set display pattern.  
 Note 3: Setting to "non" are minimum output. In addition, it moves to the next analog output setting.  
 Note 4: Underlined portions are the factory default settings for measurement elements assigned to each analog output.  
 Note 5: VA is output by scaling 0 to 100% of the rating.  
 Note 6: When Frequency (Setting menu 1.5) is set to "50Hz", Hz is output by a scale from 45Hz to 55Hz. When Frequency (Setting menu 1.5) is set to "60Hz", Hz is output by a scale from 55Hz to 65Hz.  
 Note 7: For the harmonic current, the total RMS value is output by a scale from 0 to 60% of the rating. For the harmonic voltage, the total distortion ratio is output by scaling 0 to 20%.

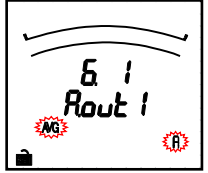

39



### 3. Setting

#### 3.9. Setting Menu 6: Setting the Analog Output

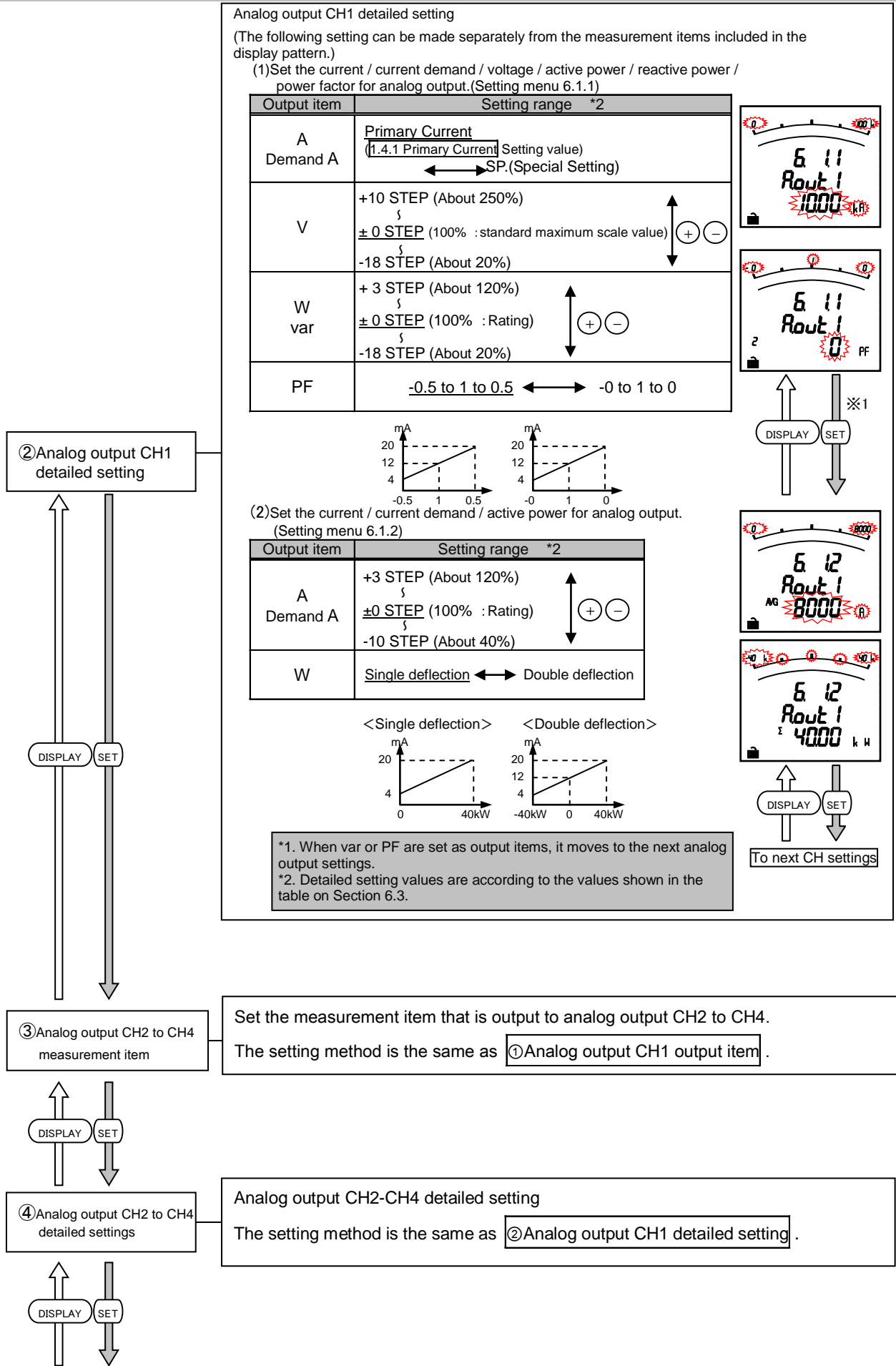

### 3. Setting

#### 3.9. Setting Menu 6: Setting the Analog Output

⑤ Analog output limit

↓

SET

↓

Setting Menu

Set analog output for when full scale is over the limit. (The same in all the CH)

Setting value	Description
oFF (No limit)	For the span value, the maximum output is +5% and the minimum output is -5%.
on (Limited)	For the the span value, the maximum output is +1% and the minimum output is -1%.



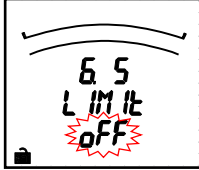

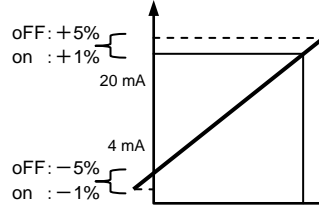
oFF: +5%  
on : +1%  
20 mA

oFF: -5%  
on : -1%  
4 mA

Note: When the output items for all analog output are set to "non," this setting is skipped.

According to the setting flow (page 16 to 21), save the changed contents, or continue to the other setting menu.



### 3. Setting

#### 3.10. Setting Menu 6: Setting the Logging function

This section shows how to set the logging function. When the ME-0000BU-SS96 optional plug-in module is not installed, this menu will be skipped. In the operation mode, press **SET** and **RESET** simultaneously for 2 seconds or more, and the following operation becomes available.

Setting Menu

↑

↓

① Logging ID

↑

↓

② Logging Data Clear

↑

↓

③ Logging-item pattern

↑

↓

DISPLAY

↑

↓

DISPLAY

↑

↓

DISPLAY

↑

↓

DISPLAY

↑

↓

Set the setting menu number to "6".  
(as shown in the right figure)



Set the ID number of the optional plug-in module: ME-0000BU-SS96.

Settable ID : 001 to 255

When ID number installed of the optional plug-in module is set, that ID number is appeared as the initial value.

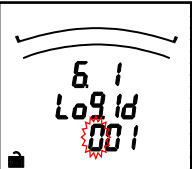

**Note** If ME96SS cannot receive the setting value of logging ID from ME-0000BU-SS96, the screen does not appear. Just wait there for a moment.

Clears logging data memorized in optional plug-in module: ME-0000BU-SS96.

no (Not clear) ↔ yES (Clear)

When "yES(Clear)" is selected at the above setting, the confirmation screen appears in order to reconfirm whether the logging data can be cleared or not.

no (Not clear) ↔ yES (Clear)





Set the Logging-item pattern to select the logging items.

Settable pattern : LP01 ↔ LP02 ↔ LP00

When LP00 is set, you can choose any 6-item.  
(For details of LP00, refer to following manual:  
ME-0000BU-SS96:Logging specifications..... LSPM-0092)  
The logging-item pattern of LP01 and LP02 is defined as follows.

"Detailed data" is memorized shorter cycle than "One-hour data".  
Logging cycle of "Detailed data" is set in ④ Detailed data logging cycle.

Phase-wire setting: 3P4W

Logging-item pattern	LP01		LP02	
	Detailed data	One-hour data	Detailed data	One-hour data
Data 1	Wh(import)	Wh(import)	Wh(import)	Wh(import)
Data 2	varh(import LAG)	Wh(export)	A <sub>AVG</sub>	Wh(export)
Data 3	VAh	varh(import LAG)	V <sub>AVG</sub> (L-L)	varh(import LAG)
Data 4	DW	varh(import LEAD)	W <sub>ε</sub>	varh(import LEAD)
Data 5	Dvar	VAh	PF	VAh
Data 6	DVA	-	Hz	-

Phase-wire setting: 3P3W\_2CT, 3P3W\_3CT, 1P3W

Logging-item pattern	LP01		LP02	
	Detailed data	One-hour data	Detailed data	One-hour data
Data 1	Wh(import)	Wh(import)	Wh(import)	Wh(import)
Data 2	varh(import LAG)	Wh(export)	A <sub>AVG</sub>	Wh(export)
Data 3	VAh	varh(import LAG)	V <sub>AVG</sub>	varh(import LAG)
Data 4	DW	varh(import LEAD)	W	varh(import LEAD)
Data 5	Dvar	VAh	PF	VAh
Data 6	DVA	-	Hz	-

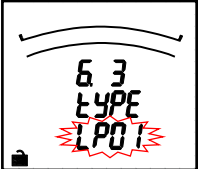

### 3. Setting

#### 3.10. Setting Menu 6: Setting the Logging function

Continued from the previous.

Phase-wire setting: 1P2W

Logging-item pattern	LP01		LP02	
	Detailed data	One-hour data	Detailed data	One-hour data
Data 1	Wh(import)	Wh(import)	Wh(import)	Wh(import)
Data 2	varh(import LAG)	Wh(export)	A	Wh(export)
Data 3	VAh	varh(import LAG)	V	varh(import LAG)
Data 4	DW	varh(import LEAD)	W	varh(import LEAD)
Data 5	Dvar	VAh	PF	VAh
Data 6	DVA	-	Hz	-

④ Detailed data  
Logging cycle

SET

Setting Menu

Set the logging cycle of detailed data when ③ Logging-item pattern is LP01 or LP02.

1min ↔ 5min ↔ 10min ↔ 15min ↔ 30min

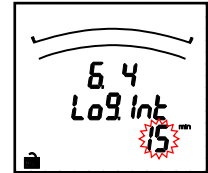

According to the setting flow (page 16 to 21), save the changed contents, or continue to the other setting menu.

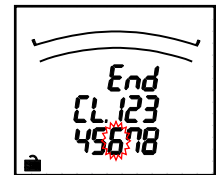

### 3. Setting

#### 3.11. Setting Menu 7: Setting Periodic Active Energy, Rolling Demand, and Digital

##### Input/Output

Set the periodic active energy, rolling demand, and digital input/output.

In the operation mode, press **SET** and **RESET** simultaneously for 2 seconds or more, and the following operation becomes available.

( For more details about each function, refer to the corresponding pages.  
 Periodic Active Energy ⇒page 72, Rolling Demand ⇒page 73, digital input/ output ⇒page 75 )

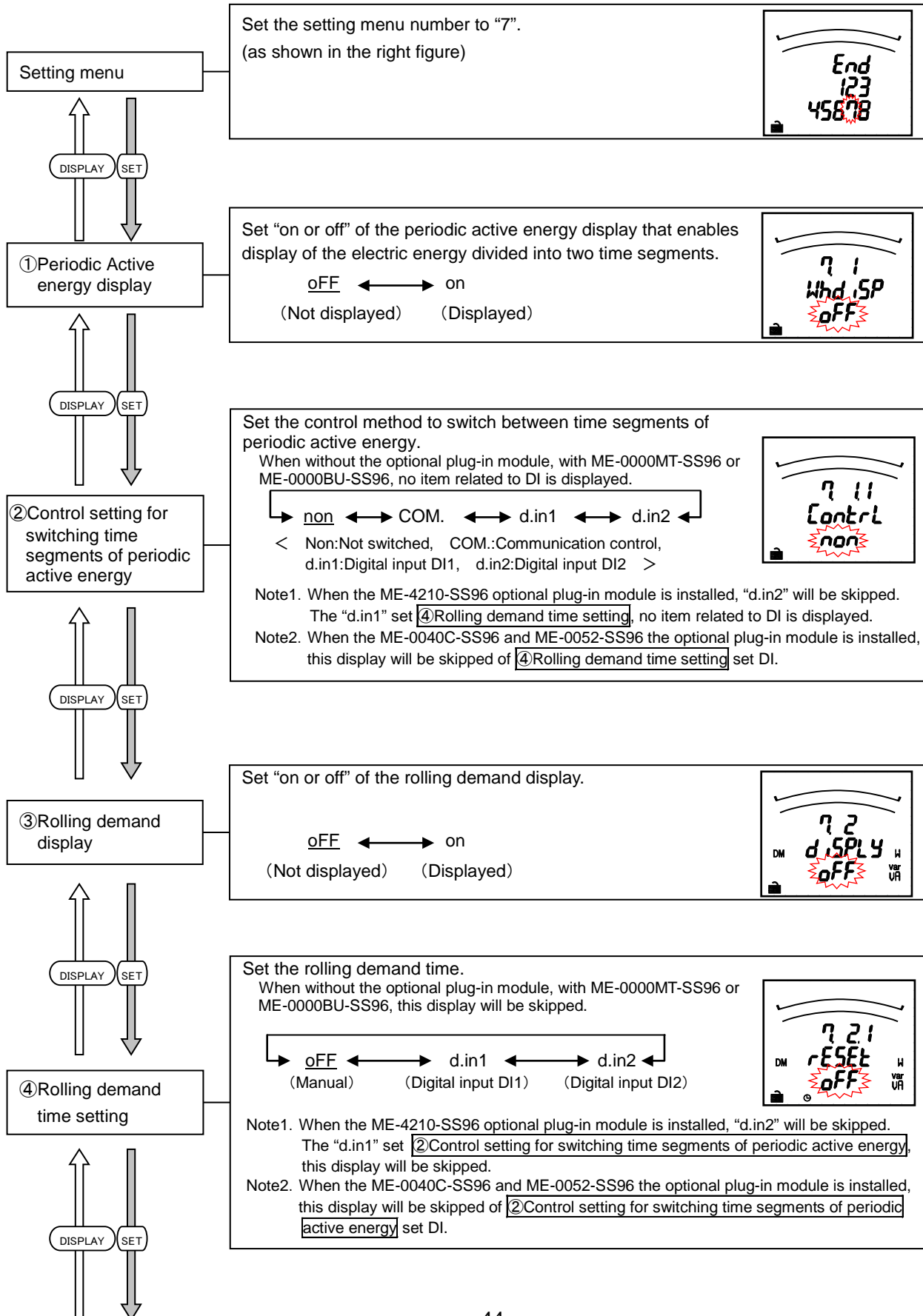

### 3. Setting

#### 3.11. Setting Menu 7: Setting Periodic Active Energy, Rolling Demand, and Digital Input/Output

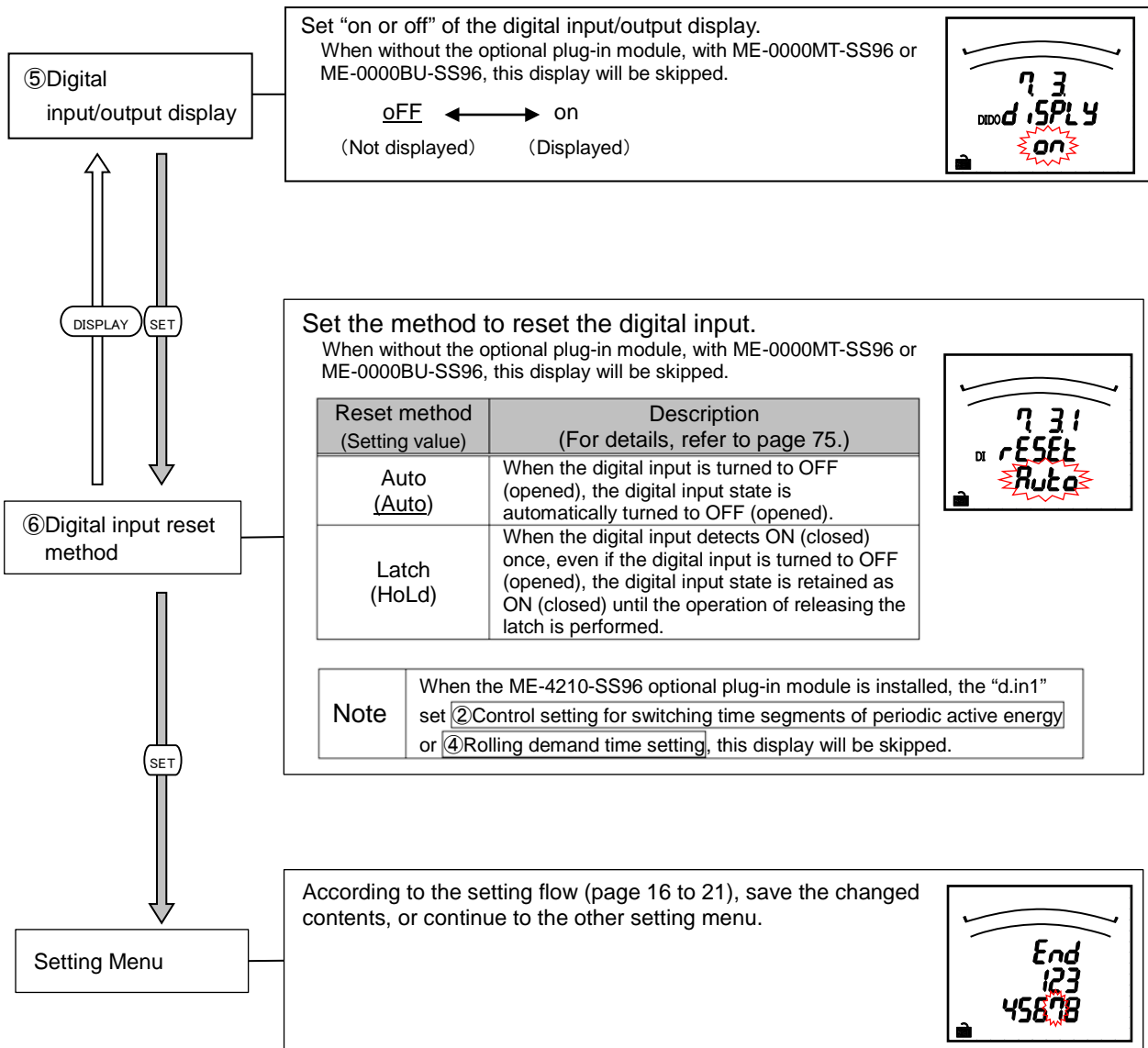

### 3. Setting

#### 3.12. Setting Menu 8: Special Settings (Setting Operation Time, Phase Display, IEC Mode)

Set the operation time, phase display, IEC mode.

In the operation mode, press **SET** and **RESET** simultaneously for 2 seconds or more, and the following operation becomes available.

( For more details about each function, refer to the corresponding pages. )  
 Operation time ⇒ page 74

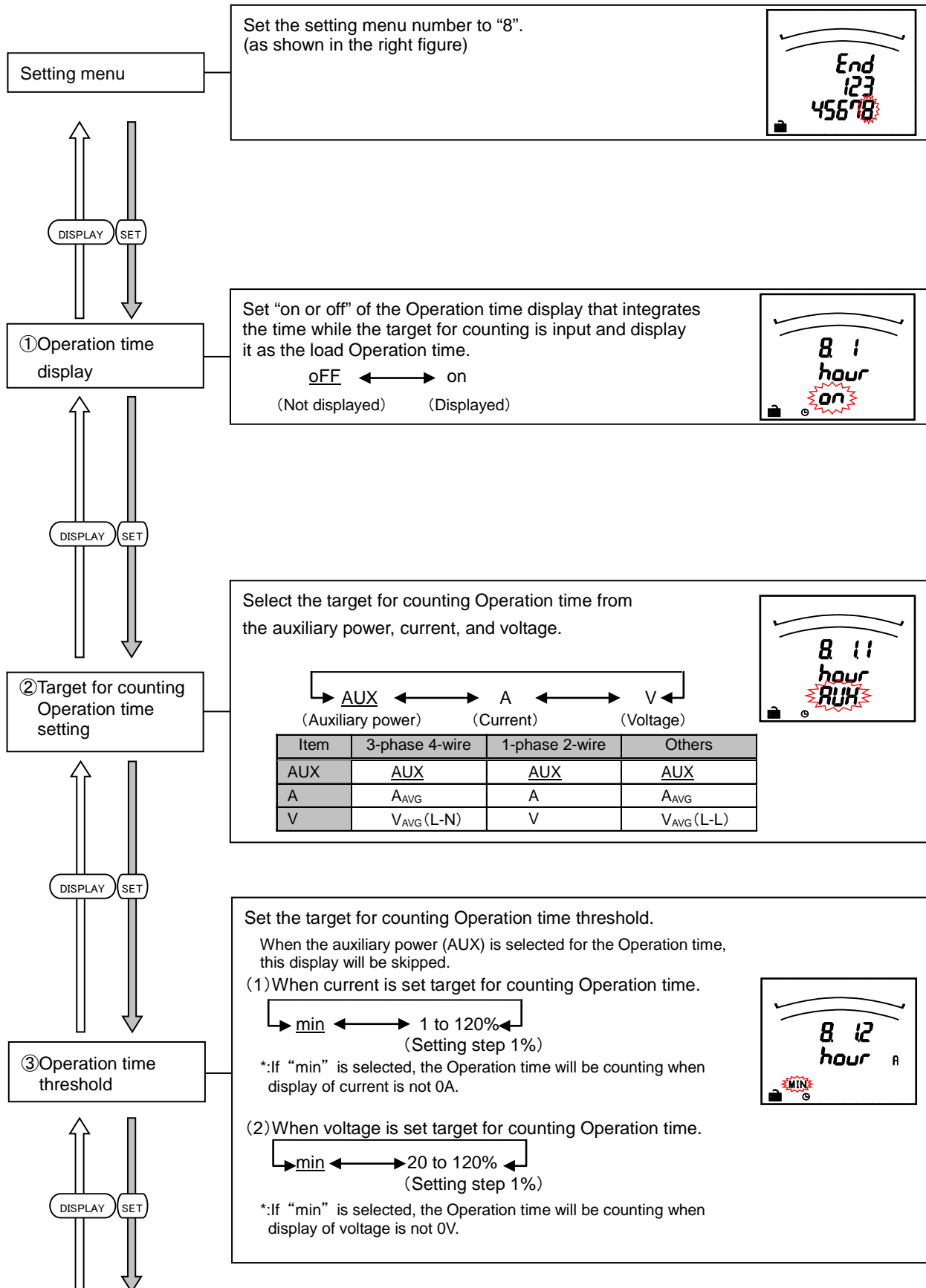

### 3. Setting

#### 3.12. Setting Menu 8: Special Settings (Setting Operation Time, Phase Display, IEC Mode)

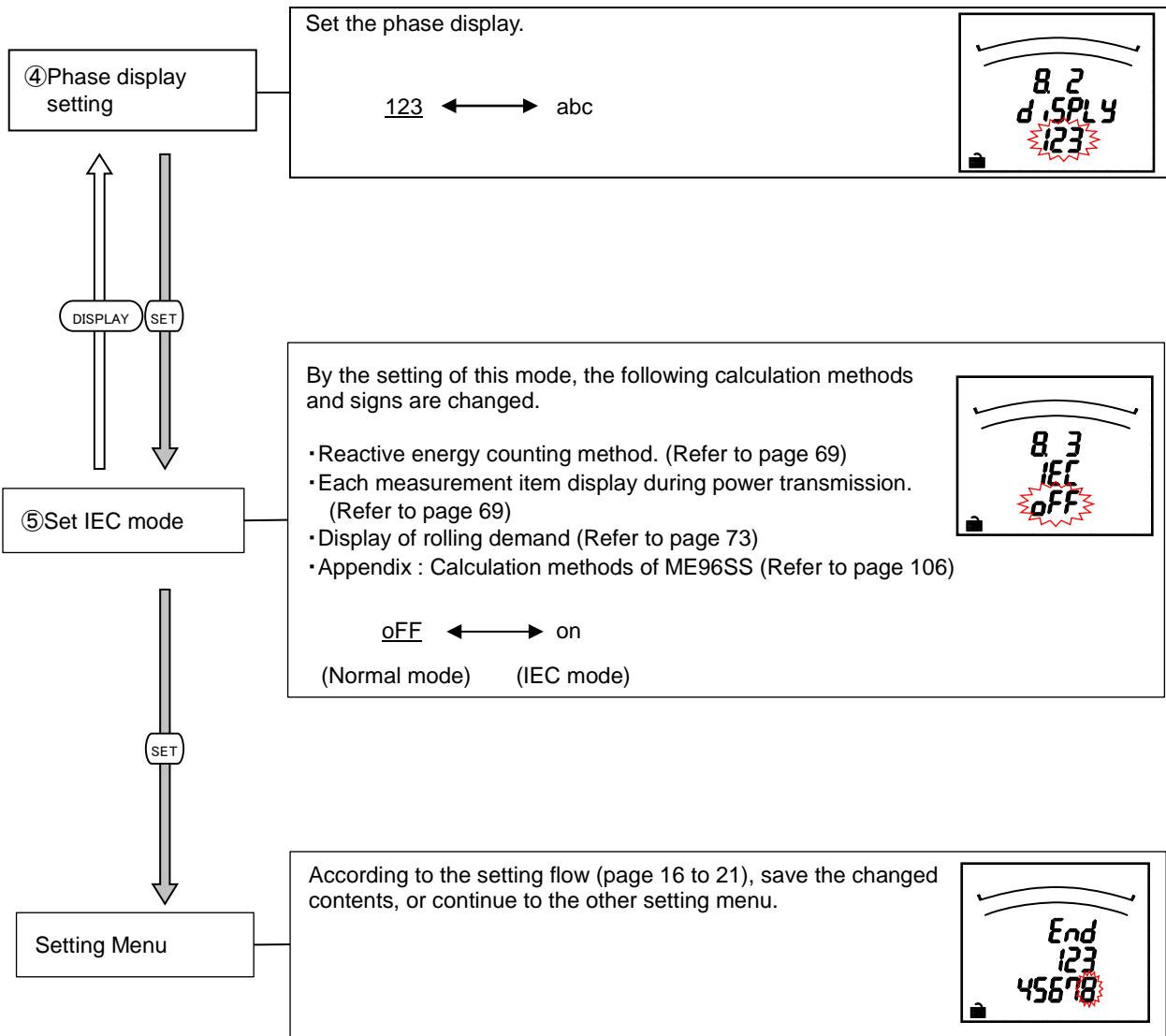



### 3. Setting

#### 3.13. Setting Menu CL: Present Time Settings for Data Logging

Set the present clock time for data logging when installed the optional plug-in module: ME-0000BU-SS96. The present clock time should be set before operating the system.

In the operation mode, press **(SET)** and **(RESET)** simultaneously for 2 seconds or more, and the following operation becomes available.

	<p>All logging data of ME-0000BU-SS96 are erased when you change the setting of "Present time" more than 31 days from the time displayed <b>① Present time display</b>. Before changing the setting of present clock time, output the logging data to the SD memory card and check the output data in the PC whether the logging data are memorized properly.</p>
---	---

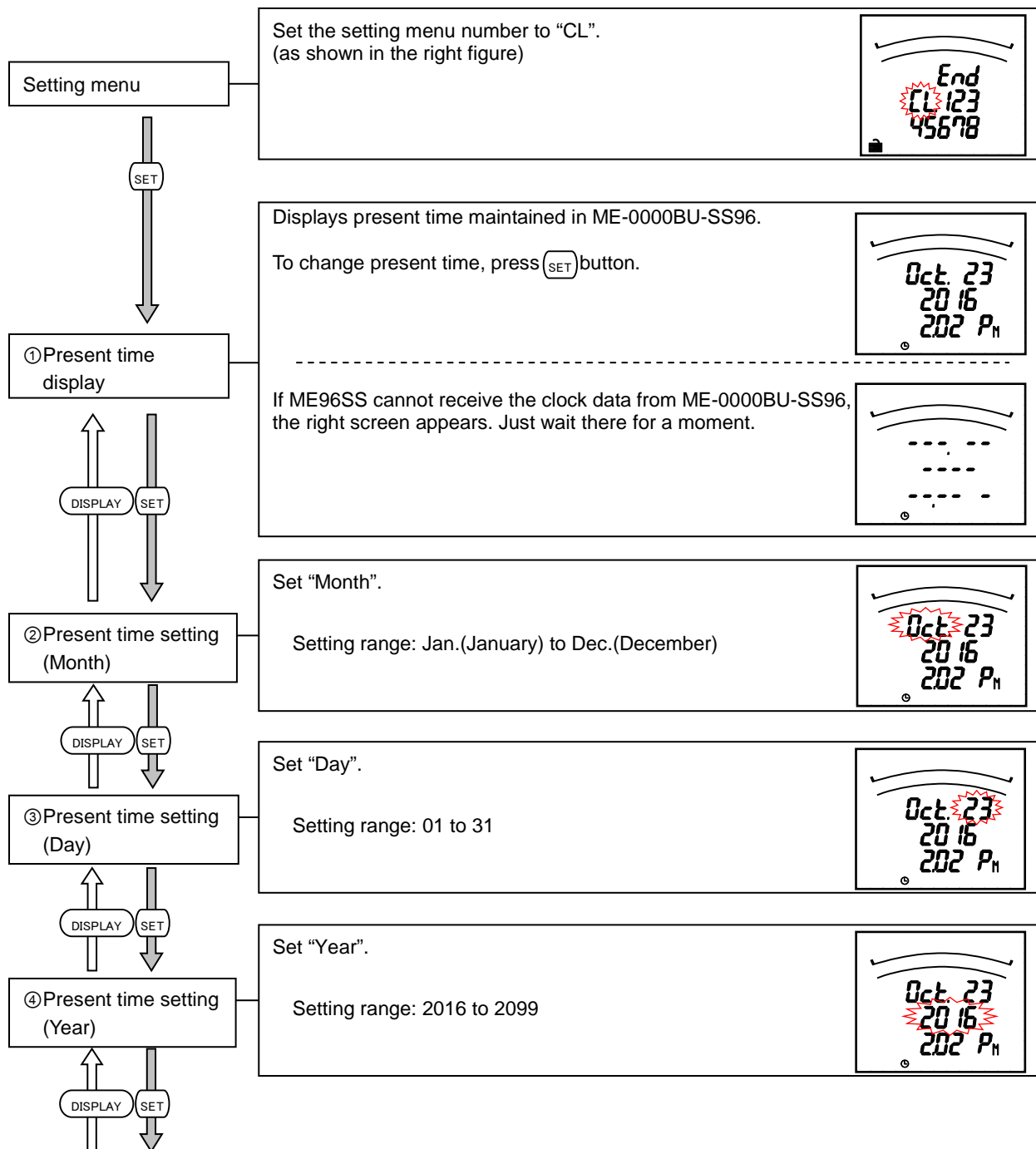

### 3. Setting

#### 3.13. Setting Menu CL: Present Time Settings for Data Logging

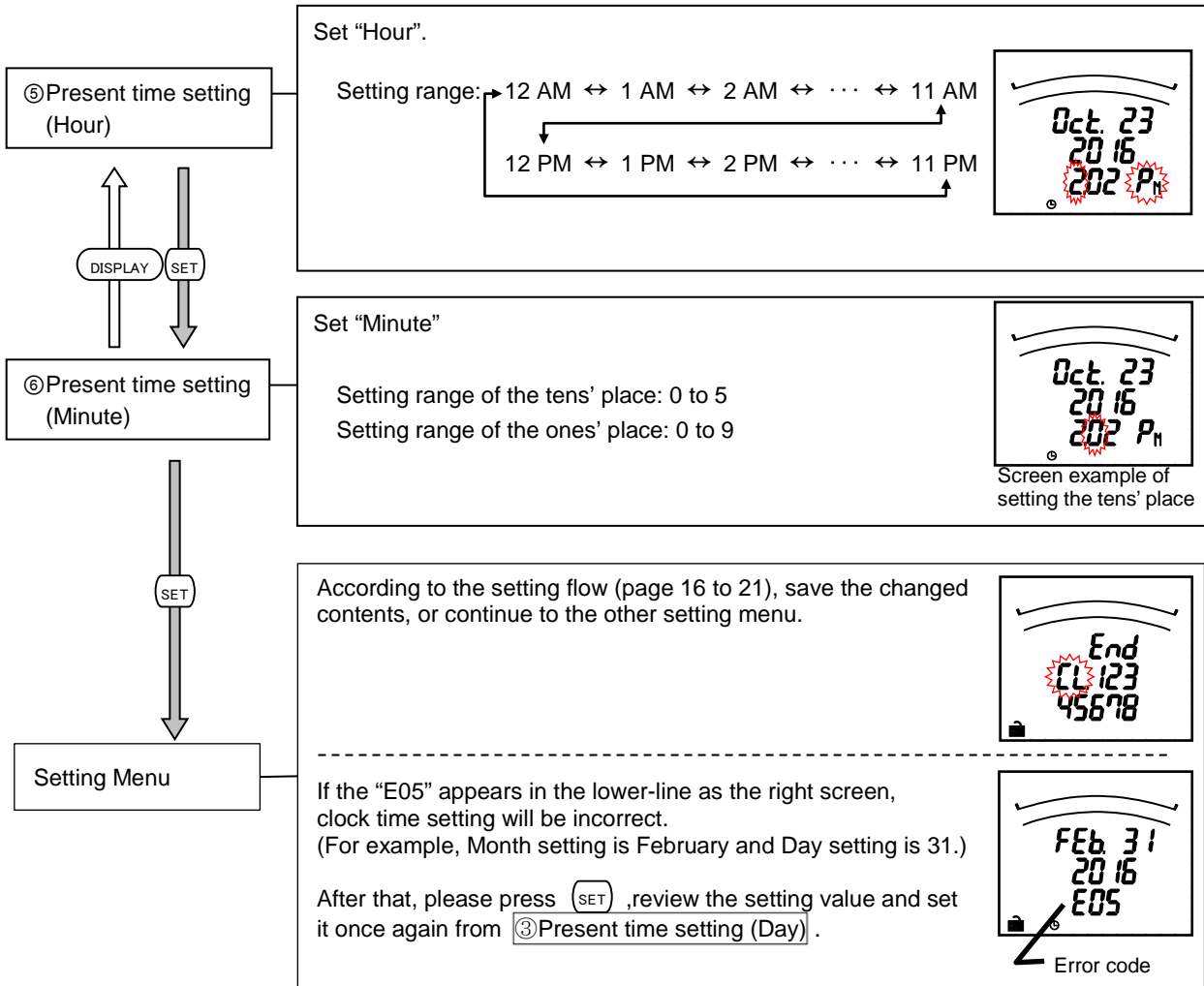

### 3. Setting

#### 3.14. Setting Value Confirmation Menus 1-9: Confirming the Settings in the Setting Menus 1-8 and Test Mode in Setting Menu 9

##### ● Setting Value Confirmation

When **(SET)** is pressed for at least 2 seconds in the operation mode, the following operation becomes available.

Setting value confirmation menu

The screen transitions and operations are the same as for Setting Menus 1 to 8 and CL.  
Refer to Setting Menus 1 to 8 and CL (pages 22 to 49).  
(Note: Settings cannot be changed in the Setting value confirmation mode.)

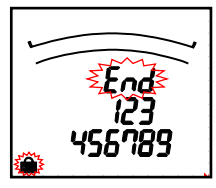

##### ● Test Mode

Press **(SET)** for 2 seconds to move the set values confirmation mode.

Select setting value confirmation menu number "9". Press **(SET)** to move to test mode.

For more information about how to use the Test Mode, refer to page 57 or later.

### 3. Setting

#### 3.15. Initializing Related Items by Changing Settings

When a setting value is changed, the related setting items and measurement data (maximum/minimum values) will return to the default settings. Refer to the following list.

Setting item to be changed		Menu 1				Menu 2	Menu 5	Menu 6	Menu 8		Change of optional plug-in module											
		Phase wire system (*1)	VT / direct voltage	CT current		MODBUS@TCP Default gateway existence	Communication Reset	Upper/lower limit alarm item	Analog output item	Target for counting Operation time		Setting of IEC mode										
CT secondary current	CT primary current			Initialized item																		
Setting item	Menu 1	Phase wire system																				
		Display pattern	●																			
		VT/direct voltage	○																			
	Menu 2	MODBUS@TCP Default gateway				●																
	Menu 3	Current scale				●																
		Voltage scale	●	●																		
		Power scale	●	●		●																
		Reactive power scale	●	●		●																
	Menu 5	Upper/lower limit alarm item	●																			
		Upper/lower limit alarm value	●						●													
	Menu 6	Analog output item	●																			
		Maximum current scale	●			●						●										
		Maximum current demand scale	●			●						●										
		Maximum voltage scale	●	●								●										
		Maximum active power scale	●	●		●						●										
		Active power single deflection/ double deflection	●									●										
		Maximum reactive power scale	●	●		●						●										
		Power factor -0.5 to 1 to 0.5/-0 to 1 to 0	●									●										
	Menu 7	Control setting for switching Periodic Active energy time segments																				●
		Setting of rolling demand digital input time period																				●
Menu 8	Threshold for counting Operation time																			●		
Measurement data	Current Maximum/minimum value	●		●	●																	
	Current demand Maximum/minimum value	●		●	●																	
	Voltage Maximum/minimum value	●	●																			
	Active power Maximum/minimum value	●	●	●	●																	
	Reactive power Maximum/minimum value	●	●	●	●																●	
	Apparent power Maximum/minimum value	●	●	●	●																●	
	Power factor Maximum/minimum value	●	●	●	●																●	
	Frequency Maximum/minimum value	●																				
	Harmonic current Maximum value	●		●	●																	
	Harmonic voltage Maximum value	●	●																			
	Rolling demand(DW,Dvar,DVA) Maximum value	●	●	●	●																●	
	Communication optional plug-in module reset (*2)	●	●		●																	●

● : The setting value will be reset to the default value.

○ : The setting will be reset to the value corresponding to the phase wire system.

\*1: The settings will not return to the default values when the setting is switched only between "1N2 display" and "1N3 display" in the 1-phase 3-wire setting.

\*2: Communication optional plug-in module is reset.

### 3. Setting

#### 3.16. Initializing All Settings

When the following operations are executed, all settings are initialized to the factory defaults. Only the settings are initialized to the defaults. The measured active energy value and operating time etc. are not initialized.

For the initializing of maximum/minimum value, refer to the section 3.15 (page 51).

(For example, if the phase wire system is changed by initializing all settings, all maximum/minimum values will be initialized.)

To initialize all settings to the factory defaults, execute the following operation from the CANCEL screen in the setting mode.

For more information about how to get to the CANCEL screen, refer to 3.1.Setting flow (page16).

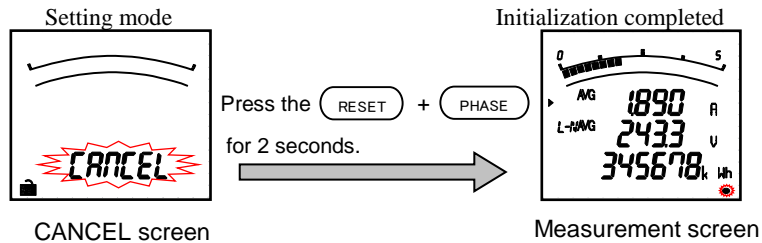

#### Note

Before initializing all settings, output the logging data of ME-0000BU-SS96 to the SD memory card and check the output data in the PC whether the logging data are memorized properly.

### 3. Setting

#### 3.17. Setting the Special Display Pattern P00

Even if there is no display pattern that you like in the display patterns P01 to P13, individual setting is available by the display pattern P00.

This setting is made in the setting menu 1. Explanation begins with the set "P00" in ②display pattern of the setting menu 1 (page 22). (Others are omitted here, so refer to the setting menu 1.)

- (1) The number of settable display is up to 4. And the number of measurement elements to be displayed is up to 12 items.

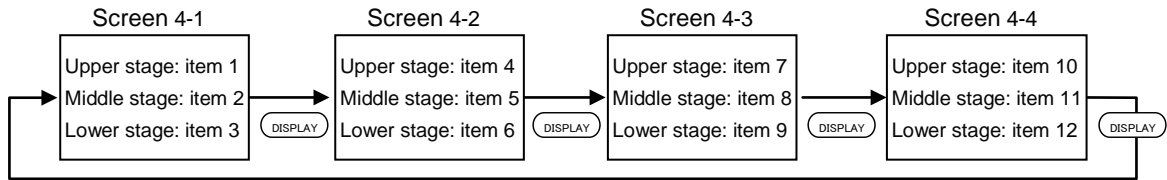

- (2) Explanation is made with the example of the following display pattern.

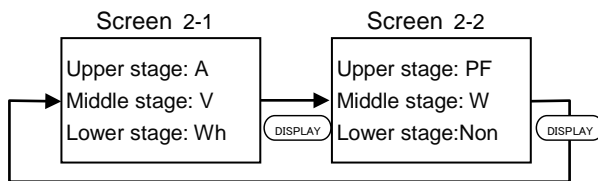

- (3) Setting method

②Display pattern

Set the display pattern.

(1) Select "P00".  
Select "P00" by  $\oplus$  or  $\ominus$  and press SET.

(2) Set the upper stage of the display 4-1 to A.  
Select "A" by  $\oplus$  or  $\ominus$  and press SET.

(3) Set the middle stage of the display 4-1 to V.  
Select "V" by  $\oplus$  or  $\ominus$  and press SET.

(4) Set the lower stage of the display 4-1 to Wh.  
Select "Wh" by  $\oplus$  or  $\ominus$  and press SET.

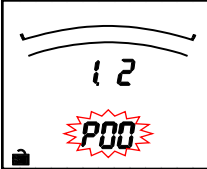

SET

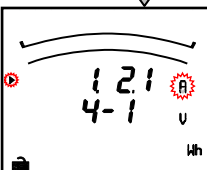

SET

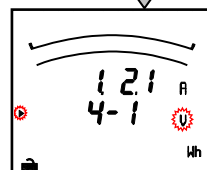

SET

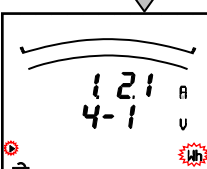

SET

### 3. Setting

#### 3.17. Setting the Special Display Pattern P00

Continued from the previous page

(5) Set the display of the display 4-2.

Select "yES" by (+) or (-) and press (SET).

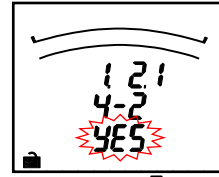

When you do not want to display the display 2, select "no" and press (SET).



(6) Set the upper stage of the display 4-2 to PF.

Select "PF" by (+) or (-) and press (SET).

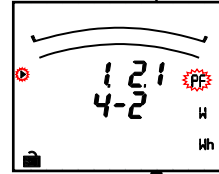

(7) Set the upper stage of the display 4-2 to W.

Select "W" by (+) or (-) and press (SET).

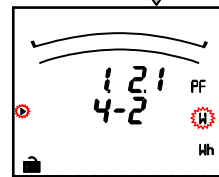

(8) Set the lower stage of the display 4-2 to no display.

Set the unit code of the lower stage to no display by (+) or (-) and press (SET).

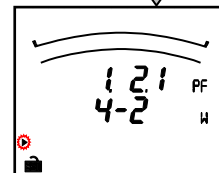

(9) Set the display 4-3 to no display.

Select "no" by (+) or (-) and press (SET).

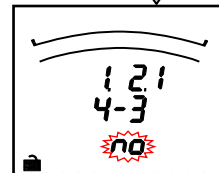

Note: When the display 4-3 is set to no display, the display 4-4 is also set to no display automatically.

Returns to the setting for the upper stage of the display 4-1.

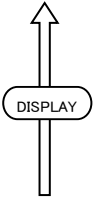

③VT / direct voltage

(hereafter same as the setting menu 1)

<b>Note</b>	<p>1. The following measurement items cannot be set by the display pattern "P00." Set them separately in the "Setting menu 3", "Setting menu 7" and "Setting menu 8."</p> <p>Reactive energy (imported LEAD), Reactive energy (exported LAG), Reactive energy (exported LEAD), Harmonic current, Harmonic voltage, Periodic active energy, Rolling demand, Digital input, Digital output, Operation time</p> <p>2. The phases of current and voltage cannot be specified. Press the (PHASE) button in the operation mode for switching phases.</p> <p>3. For the settings other than the 3-phase 4-wire setting, the following measurement items cannot be set.</p> <p>N-phase current, N-phase current demand, apparent power, apparent energy</p>
-------------	---

### 3. Setting

#### 3.18. Examples of Simple Settings

The following shows a simple setting example.

- Setting Example Model: ME96SSRA-MB(Not optional plug-in unit)
  - Phase wire system : 3-phase 4-wire
  - Measuring element : A, V, W, PF
  - Input Voltage :220/380V
  - CT primary current : 200A
  - CT Secondary current:5A
  - frequency :50Hz
  - MODBUS® RTU: address 1, baud rates 19.2kbps, parity even, stop bit 1

#### ■ Setting Procedure

Items of which setting value need to be changed are indicated by  .

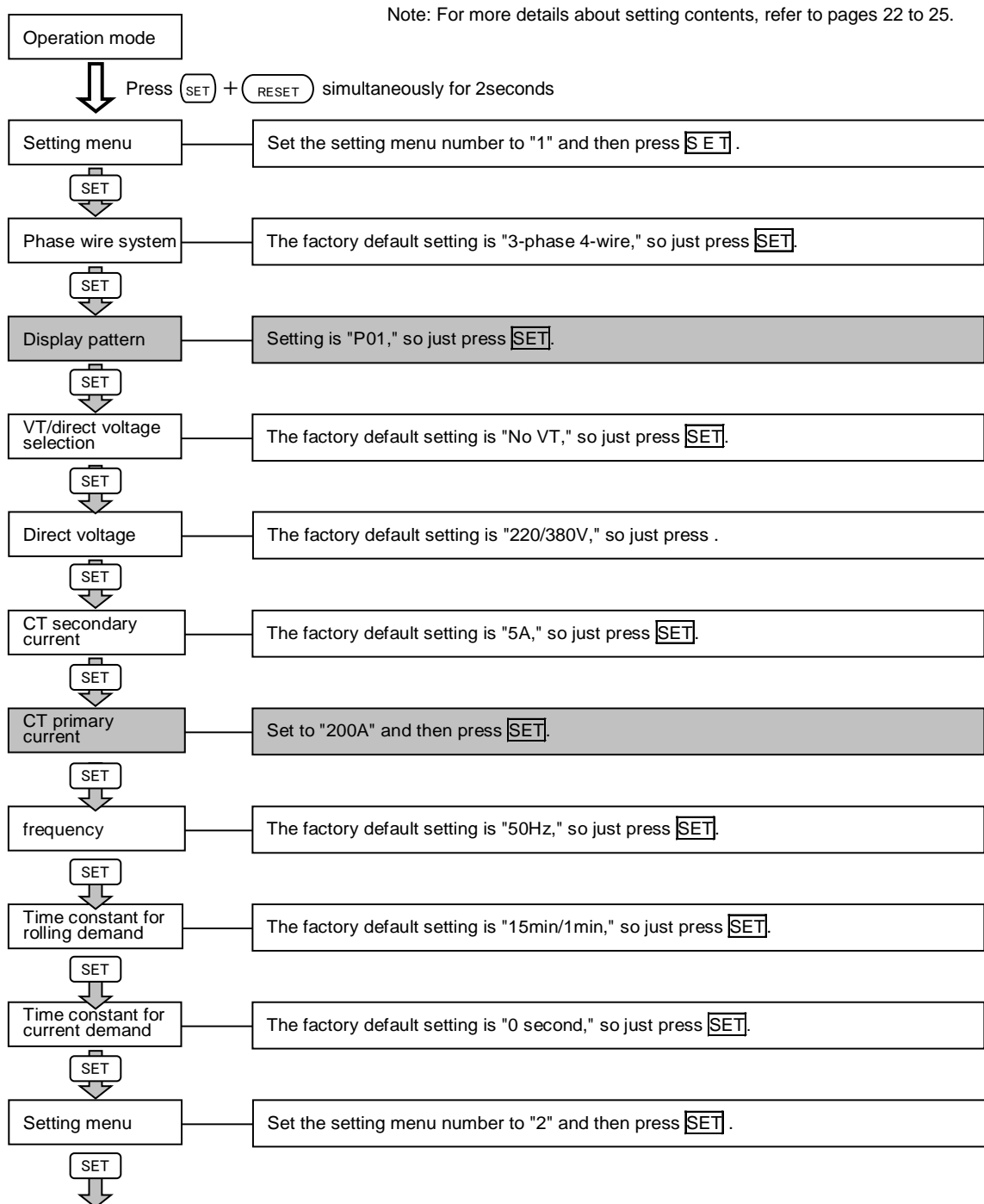



### 3. Setting

#### 3.18. Examples of Simple Settings

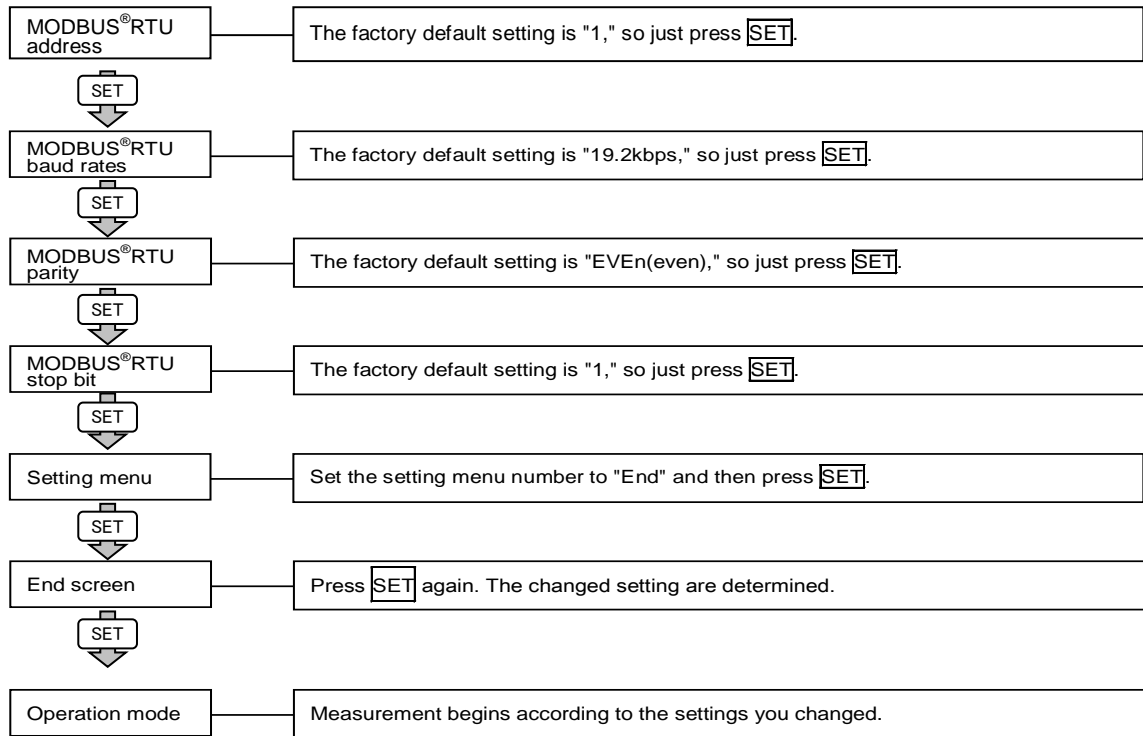

## 4. Using Test Mode

Test mode includes functions that can be used for start-up of equipment.  
The following table shows what can be done in the test mode.

Test menu	Description
1. Communication test	For models with a communication function, it is possible to monitor fixed numerical data without measurement (voltage/current) input. Use this for checking with the host system.
2. Alarm output/Digital output operation test	For functions with alarm output, it is possible to confirm alarm output (digital point output) without measurement (voltage/current) input. Use this for confirming connection with the contacted device.
3. Zero span adjustment for analog output	For functions with analog output, zero span adjustment can be done for analog output. Adjust this when matching with the receiver side and when output changes.
4. Analog output operation test	For functions with analog output, it is possible to confirm analog output operation without measurement (voltage/current) input. Use this for confirming connection with the receiver.
5. Pulse output operation test	For functions with pulse output, it is possible to confirm pulse output operation without measurement (voltage/current) input. Use this for confirming connection with the receiver.

### ■ Test Procedure

- ① Press **SET** for 2 seconds to move to the set value confirmation mode.
- ② Select setting value confirmation menu number "9" by **+** and **-**.
- ③ Press **SET** to move to test mode.
- ④ Execute tests using each test menu. (Refer to pages 58 to 62)

### ■ Test Mode Flow

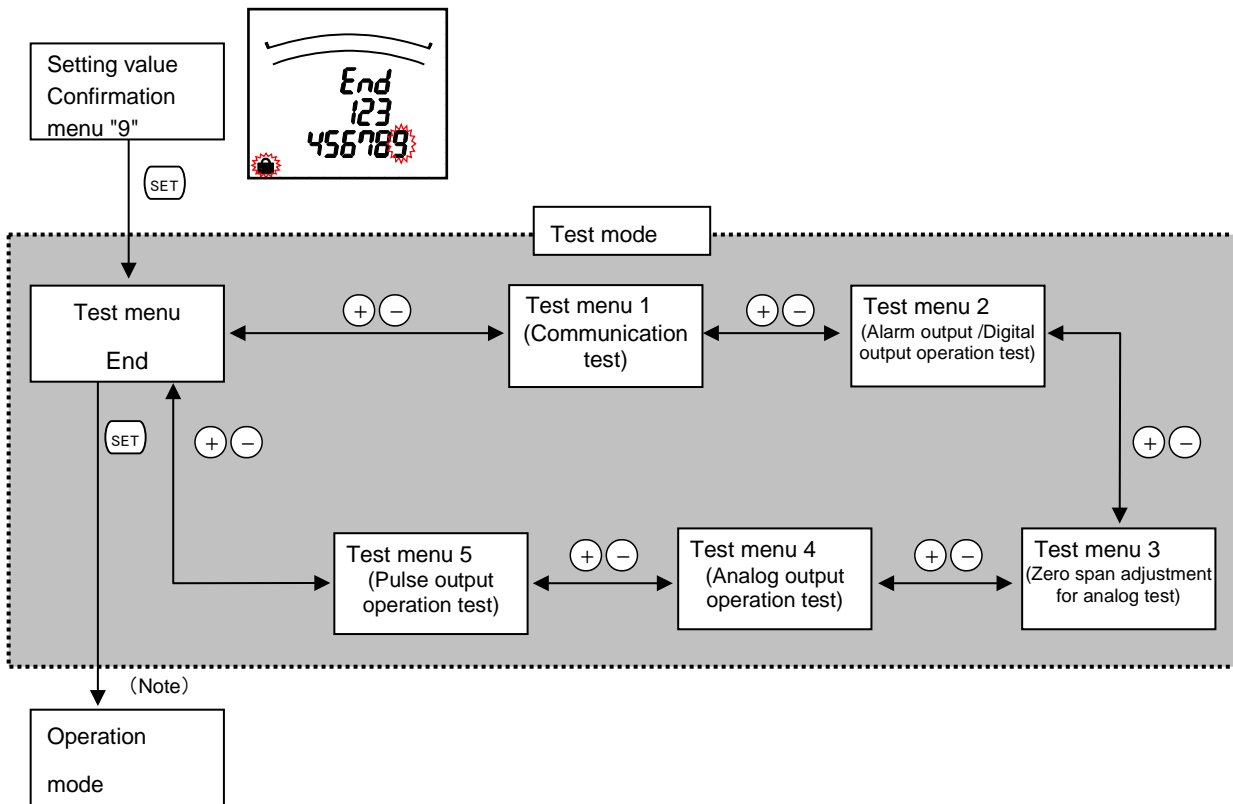

(Note) The screen momentarily turns off.

<b>Note</b>	When moving the test mode, ME-0000BU-SS96 becomes power outage state not to be logging the test data. Therefore, the system log of "Power failure occurred" is recorded in ME-0000BU-SS96 and <b>COM</b> of the LCD is blinking.
-------------	--

## 4. Using Test Mode

### 4.1. Test Menu 1: Communication Test

In the setting value confirmation mode, when the menu number is set to "9", you will enter the test mode.

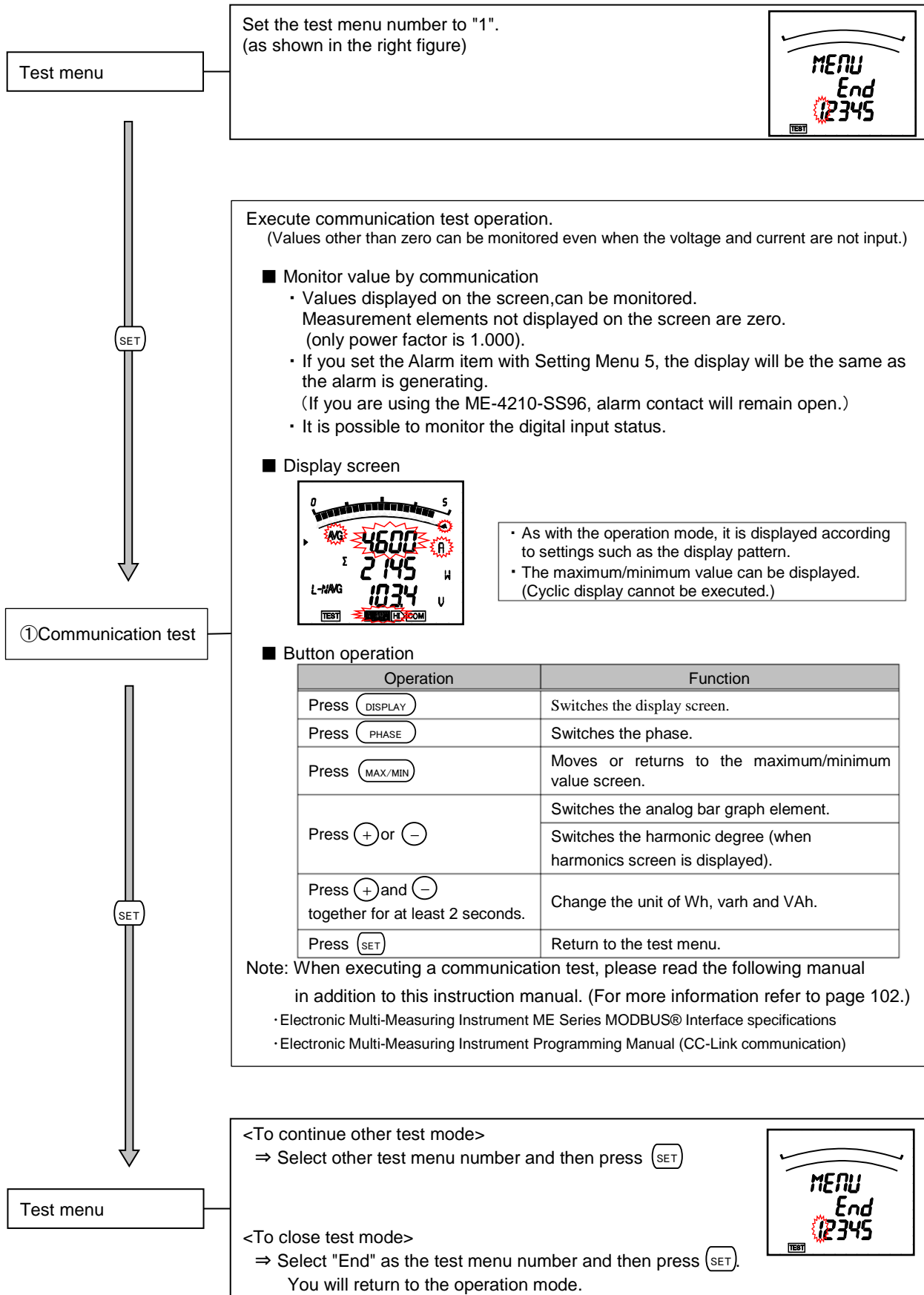

## 4. Using Test Mode

### 4.2. Test Menu 2: Alarm Output/Digital Output Operation Test

The following operations are available in the test mode.

- When the ME-4210-SS96 or ME-0052-SS96 optional plug-in module is not installed, this test menu will be skipped.
- When **⑨Pulse/Alarm output 1**(Setting Menu 5) and **⑫Pulse/Alarm output 2**(Setting Menu 5) is not set to "AL", this test menu will be skipped.(ME-4210-SS96)

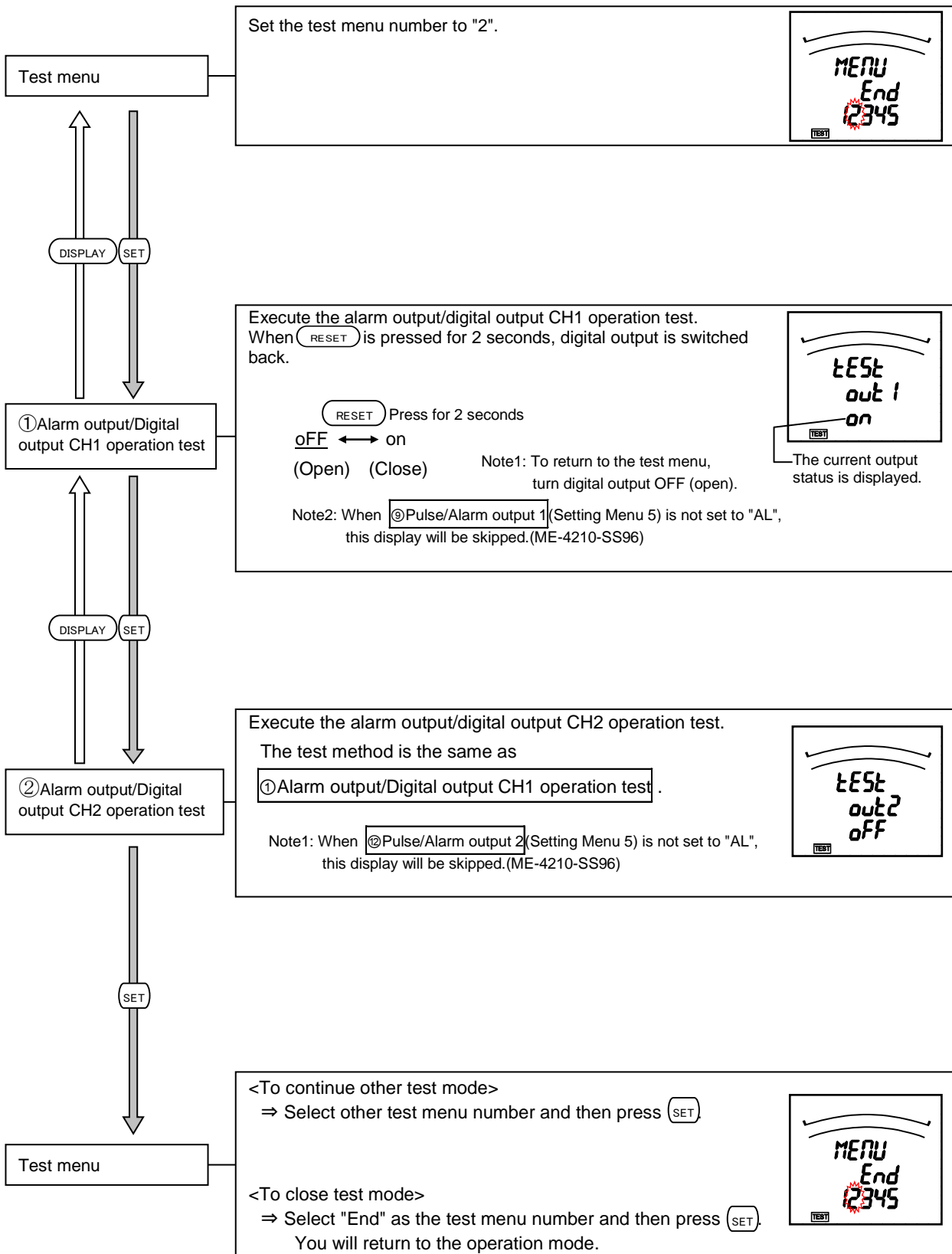

## 4. Using Test Mode

### 4.3. Test Menu 3: Zero Span Adjustment for Analog Output

The following operations are available in the test mode.

When the ME-4210-SS96 optional plug-in module is not installed, this test menu will be skipped.

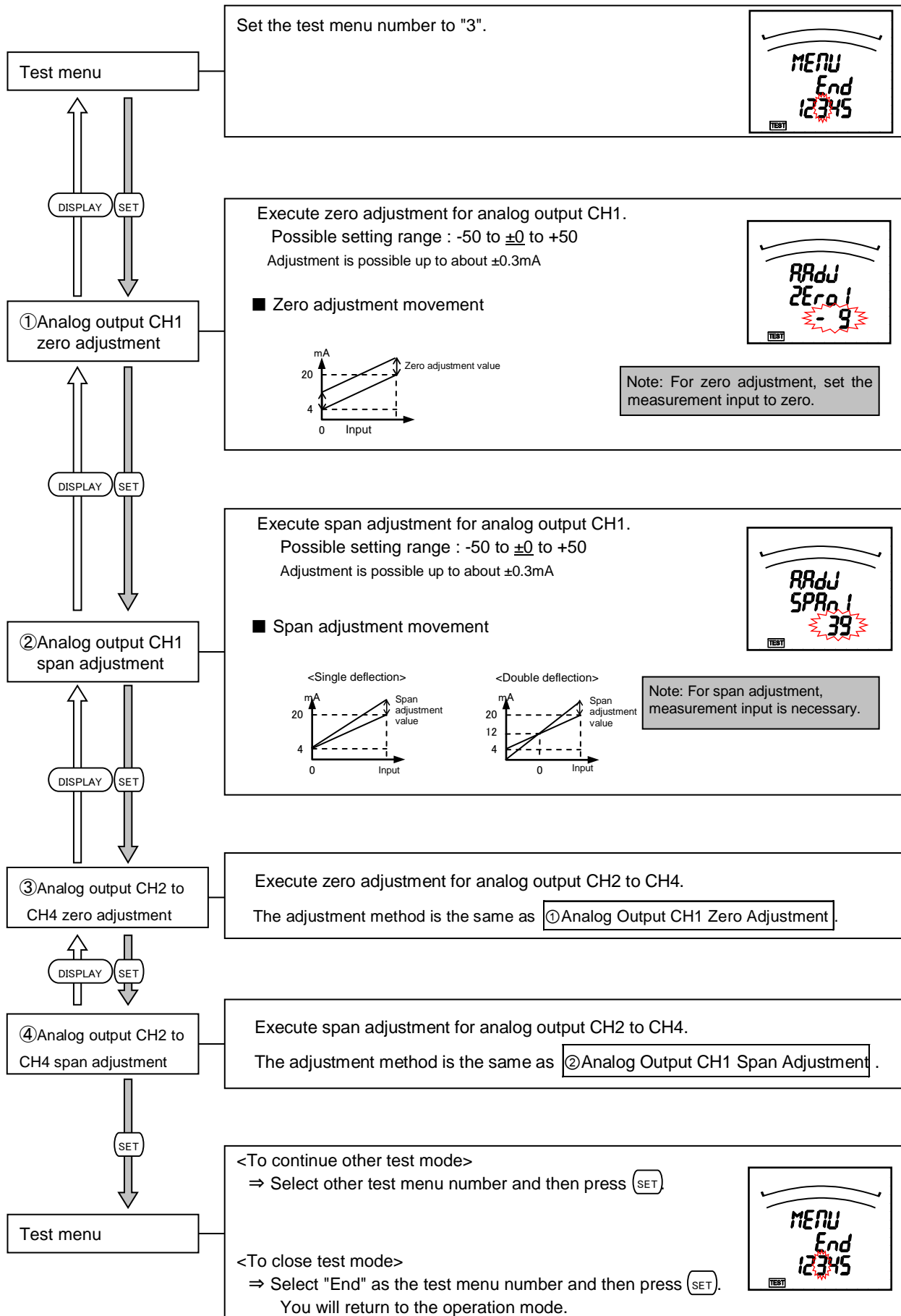

## 4. Using Test Mode

### 4.4. Test Menu 4: Analog Output Operation Test

The following operations are available in the test mode.

When the ME-4210-SS96 optional plug-in module is not installed, this test menu will be skipped.

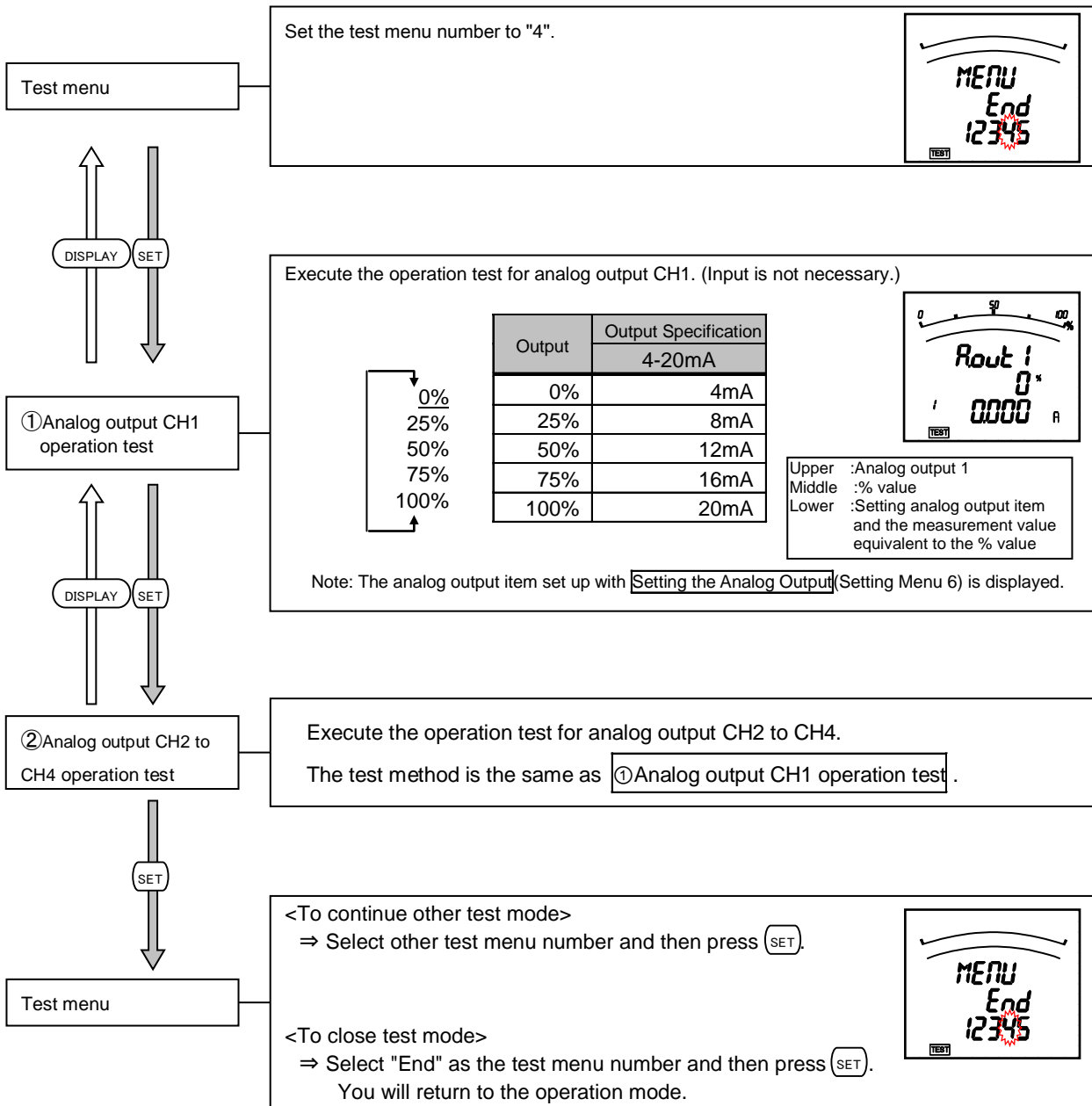

## 4. Using Test Mode

### 4.5. Test Menu 5: Pulse Output Operation Test

The following operations are available in the test mode.

- When the ME-4210-SS96 optional plug-in module is not installed, this test menu will be skipped.
- When **⑨**Pulse/Alarm output 1(Setting Menu 5) and **⑫**Pulse/Alarm output 2(Setting Menu 5) is not set to "PULSE", this test menu will be skipped.(ME-4210-SS96)

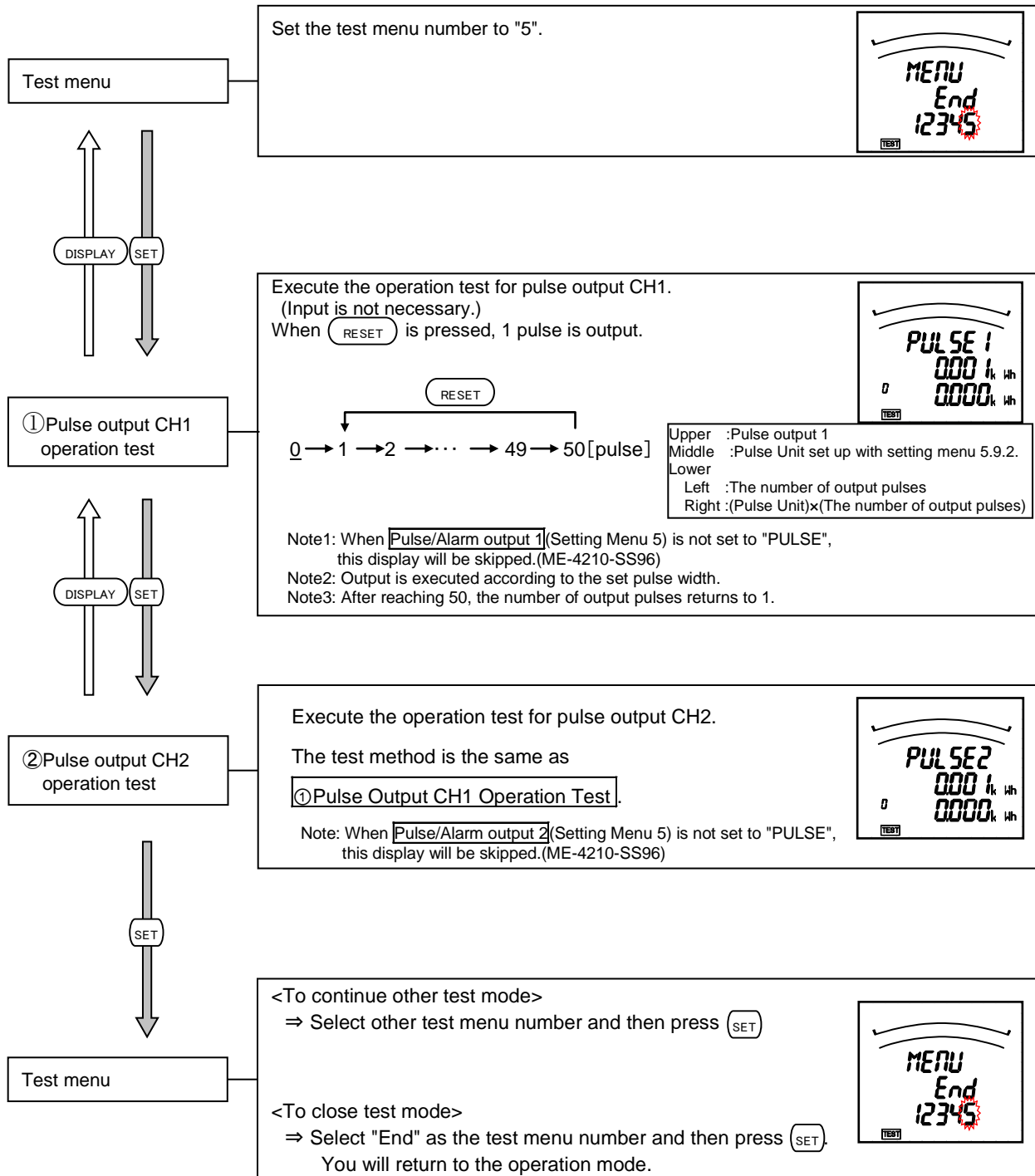

# 5. Operation

## 5.1. Basic Operation

The following explains basic usages during operation.

Display items and the order differ depending on the phase wire method setting display pattern settings and additional screen. For more information about detailed display patterns, refer to pages 77 and 78.

### ● Switch display

By pressing **DISPLAY**, the measurement display will switch over.

By pressing **DISPLAY** + **-**, the measurement display will switch over in reverse.

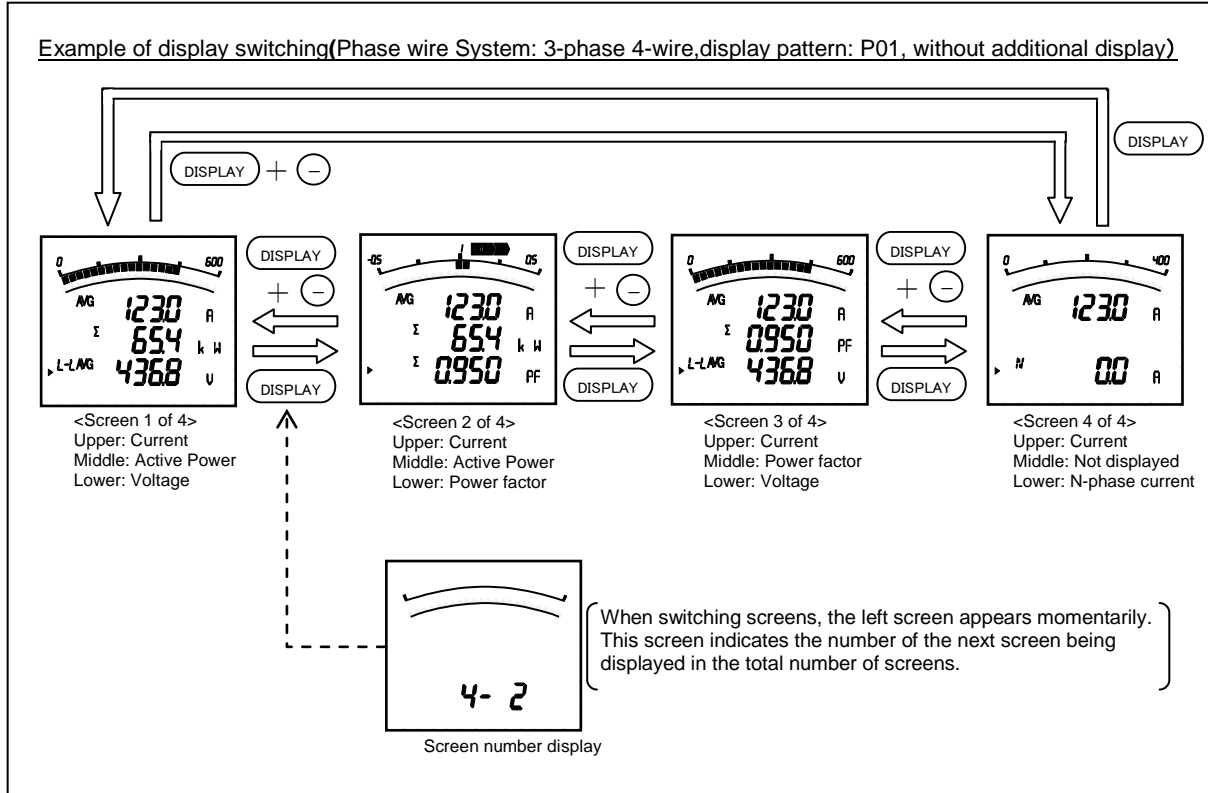

### ● Switch phase

By pressing **PHASE** the current phase and the voltage phase will switch over.

The phase cannot be switched in the following cases.

- Measurement elements without phase (Frequency)
- Active power, reactive power, apparent power and power factor for settings other than 3-phase 4-wire
- When the setting is 1-phase 2-wire

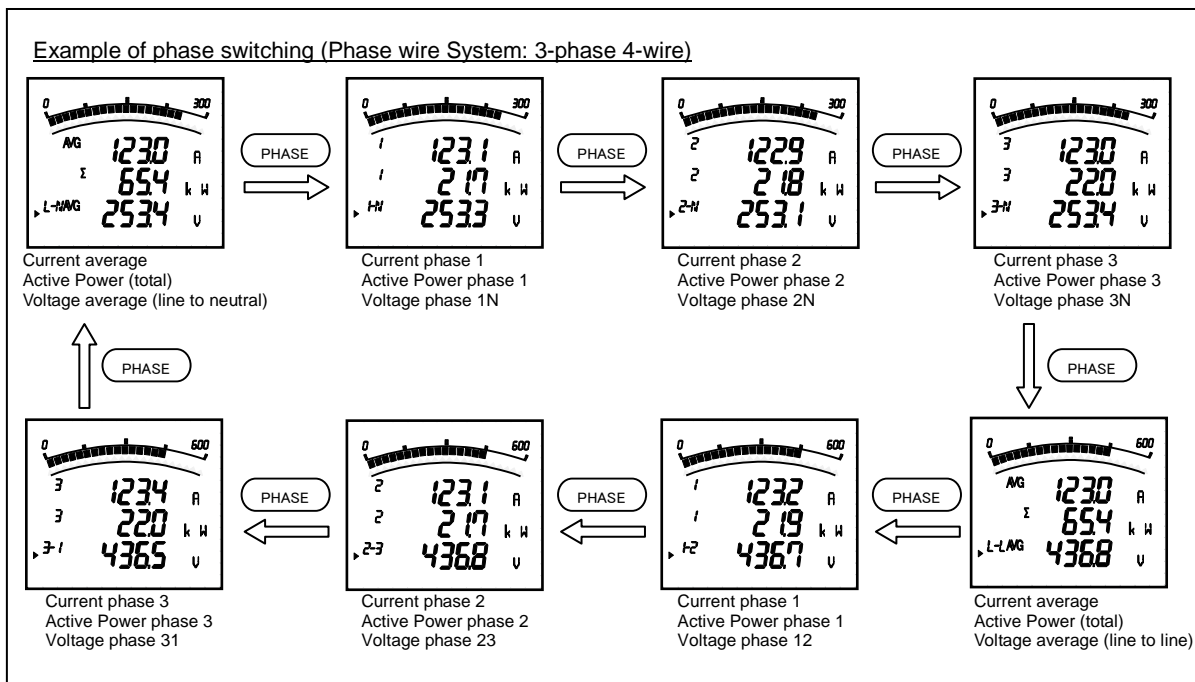



## 5. Operation

### 5.1. Basic Operation

#### ● Bar graph display

Bar graph displays the measurement element indicated with “▶” or “▲”.

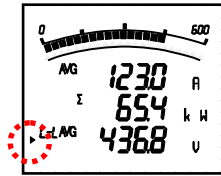

(Example) Lower element (V) displayed on bar graph

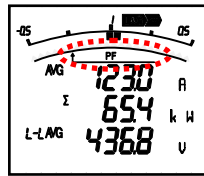

(Example) PF displayed on bar graph

#### ● Switching measurement factors displayed on bar graphs

Press the (+) or (-) button to switch.

The following example is the case of “3 measuring items of screen are different” or “2 measuring items of screen are same”. In the case of “3 measuring items of screen are same”, the bar graph of average value or total value appear instead of “▶(Upper)”, “▶(Middle)” and “▶(Lower)”.

- (The bar graph cannot be displayed in the following cases.)
- When active energy / reactive energy / apparent energy are selected
  - When a line without measurement display is selected
  - Rolling Demand Display
  - Harmonics Display

(1) For 3-phase 4-wire

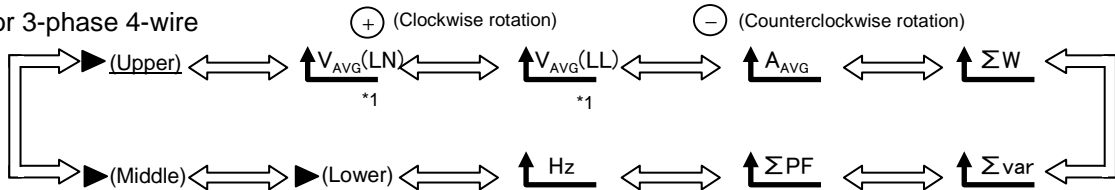

\*1: “LN”, “LL” does not appear.

(2) For 3-phase 3-wire, 1-phase 3-wire

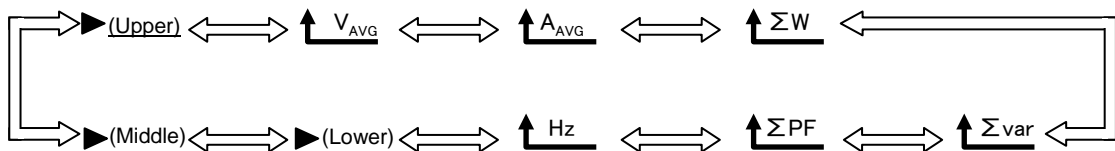

(3) For 1-phase 2-wire

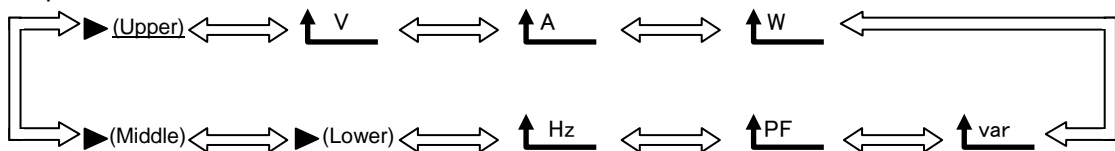

## 5. Operation

### 5.1. Basic Operation

#### ● Cyclic Display

In cyclic display, display and phases automatically change at every 5 seconds.

When **DISPLAY** is pressed for about 2 seconds, the cyclic display appears.

When **PHASE** is pressed for about 2 seconds, the cyclic phase appears.

By pressing any other buttons except **SET**, cyclic display mode ends.

Note 1: Before shifting to the cyclic display change screen, the display flickering 3 times.

Note 2: In the cyclic display, drawing number is not displayed.

Note 3: In the maximum value and the minimum value display, cyclic display is not available.

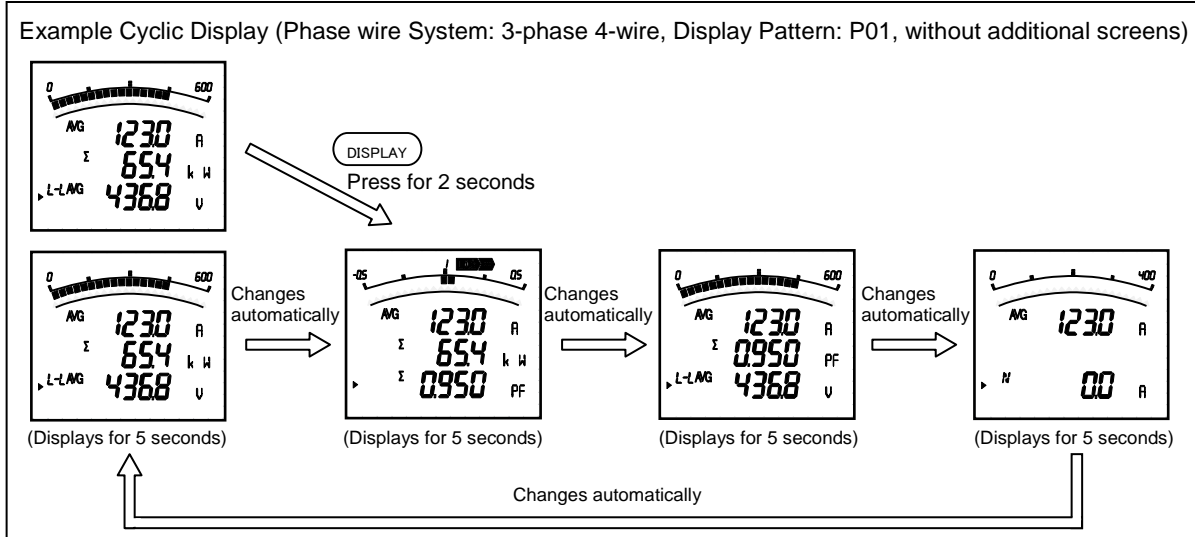

#### ● Harmonics display

Harmonic RMS value and distortion ratio can be displayed.

It is necessary to set the harmonics display settings before displaying. (Refer to page 32)

##### ■ Measurement items

Degree	Harmonic current		N-phase harmonic current		Harmonic voltage	
	RMS value	Distortion ratio	RMS value	Distortion ratio	RMS value	Distortion ratio
Harmonic total	○	○	○	—	○	○
1st	○	—	○	—	○	—
3rd, 5th, 7th, 9th, 11th, 13th, 15th, 17th, 19th	○	○	○	—	○	○

##### ■ Example Display

<Example of harmonic current total display>

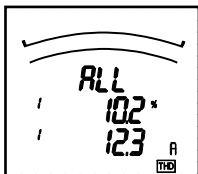

<Example of harmonic voltage 5th display>

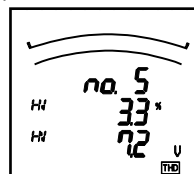

Upper: Degree  
Middle: Distortion ratio  
Lower: RMS value

Note : Harmonic total is shown by "ALL".

## 5. Operation

### 5.1. Basic Operation

#### ● Harmonics display (Continued from previous page)

■ Switching degree / phase (Phase wire System: 3-phase 4-wire)

Press the (+) or (-) button to switch the degree.

Press (PHASE) to switch phases.

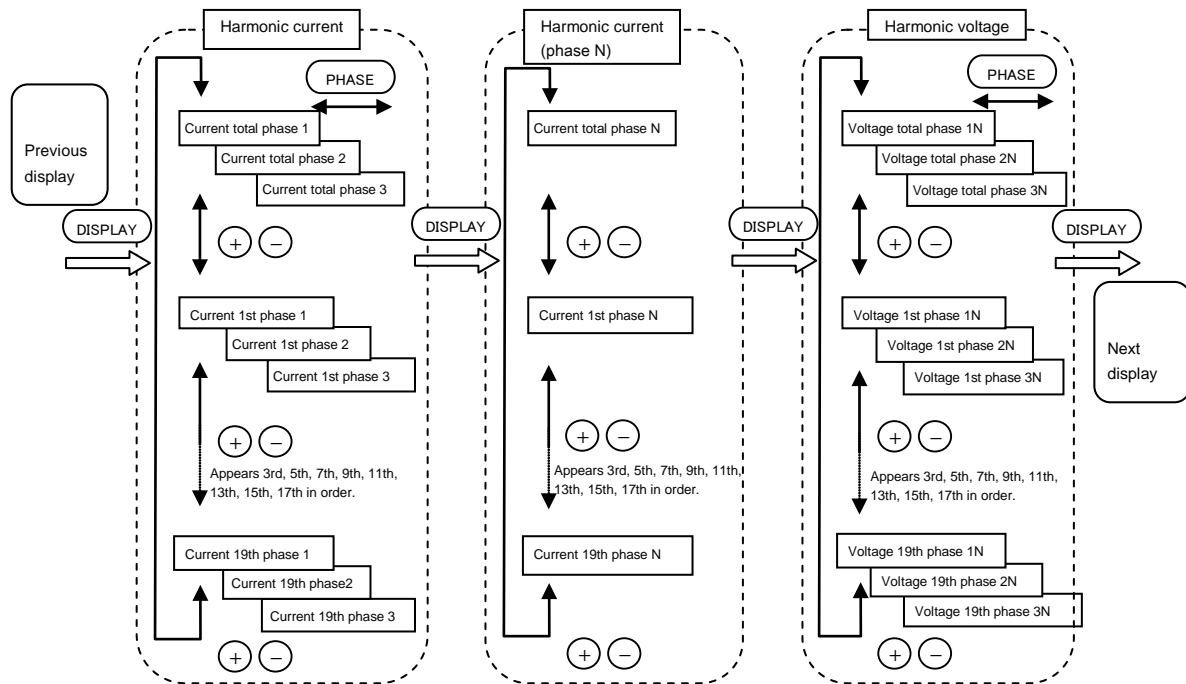

Note: For harmonic measurement, the following phases are not displayed.

Phase wire system	Harmonic current	Harmonic voltage
3-phase 3-wire	3CT	—
	2CT	2-phase
1-phase 3-wire	1N2 display	N-phase
	1N3 display	N-phase

## 5. Operation

### 5.1. Basic Operation

#### ● Maximum value and minimum value display

For the maximum / minimum value display screen, the maximum value, current value, and minimum value for each measurement item are displayed on one screen.

However, for harmonics only the following maximum values are displayed.

Harmonic current: Total, 1st to 19th (only odd number) effective values for where the phase was largest for each phase.  
Harmonic voltage: Total distortion factor, 1st effective value, 3rd to 19th (only odd number) content factors for where the phase was largest for each phase

#### ■ Example Display

<Example of current>

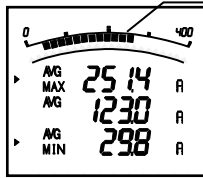

The bar graph turns on only between the maximum value and minimum value.  
Upper: Maximum value  
Middle: Current value  
Lower: Minimum value

<Example of current harmonics>

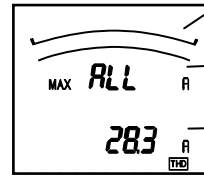

Harmonics won't display as bar graph.  
Harmonic degree  
Maximum value

#### ● Display of maximum value and minimum value

When **MAX/MIN** is pressed, the display is changed into the maximum value and minimum value display. And when **MAX/MIN** is pressed, the display changes back to the present value display.

Example of switching between present value display and maximum/minimum value display

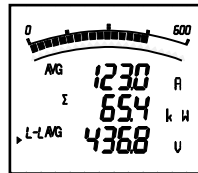

Present value display

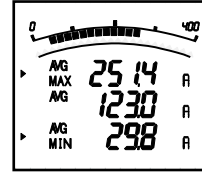

Maximum value and minimum value display

On maximum/minimum value display, the following operation is also possible as current value display.

Button operation	Function
Press <b>DISPLAY</b>	Measurement items switch according to the following order. However, measurement items that are not included in the phase wire method display pattern setting and additional screens are not displayed. <div style="text-align: right;"> <p>AN: N-phase current DA: Current demand DAN: N-phase current demand HI: Harmonic current HIN: N-phase harmonic current HV: Harmonic voltage</p> </div> <pre>       → A → AN → DA → DAN → V → W → var →       ← HV ← HIN ← HI ← Hz ← PF ← VA ←           </pre>
Press <b>PHASE</b>	3-phase 4-wire: A and DA switch as <pre>       → Average → 1 Phase → 2 Phase → 3 Phase →           </pre> V switches as <pre>       → VAVG(L-N) → V1N → V2N → V3N → VAVG(L-L) → V12 → V23 → V31 →           </pre> W, var, VA, PF switch as <pre>       → Total → 1 Phase → 2 Phase → 3 Phase →           </pre> AN, DAN and Hz do not have phase switching. 3-phase 3-wire, 1-phase 3-wire: Phase for A, DA and V switch. 1-phase 2-wire: No phase switch.
Press <b>+</b> or <b>-</b>	The harmonic degree switch. (Only for harmonics display)
Press <b>DISPLAY</b> for 2 seconds	Switches to measurement item cyclic display.
Press <b>PHASE</b> for 2 seconds	Switches to phase cyclic display.

#### ● Clear the maximum/minimum value

On the maximum/minimum value display screen, press the **RESET** for 2 seconds to clear the maximum/minimum value for the displayed measurement item to the present value.

On the maximum/minimum value display screen, press the **+** and **RESET** together for 2 seconds to clear all maximum/minimum values to the present value.

When the password protection setting is enabled, maximum/minimum values are cleared after you enter the password. Also, you can clear all maximum/minimum values by communication function. (In this case, the password is not necessary.)

## 5. Operation

### 5.1. Basic Operation

#### ● Active Energy / Reactive Energy / Apparent Energy Display

##### ■ Display format

The following table shows the display format of active energy / reactive energy / apparent energy based on the total load.

$$\text{Total load power [kW]} = \frac{\alpha \times (\text{VT primary voltage}) \times (\text{CT primary current})}{1000}$$

$\alpha$  : 1 1-phase 2-wire  
 2 1-phase 3-wire  
 $\sqrt{3}$  3-phase 3-wire  
 3 3-phase 4-wire

※1. For the direct voltage setting, the direct voltage is used for calculation instead of the VT primary voltage.

※2. For 3-phase 4-wire or 1-phase 3-wire, the VT primary voltage and direct voltage are calculated using the line to phase voltage.

Total load [kW]	Display type	
	Digital Display	Unit
Less than 10	888888	kWh
10 or higher and less than 100		(Unit can be changed from Wh/kWh/MWh.)
100 or higher and less than 1000		
1000 or higher and less than 10000		
10000 or higher and less than 100000		MWh
100000 or higher	(Unit can be changed from Wh/kWh/MWh.)	

\* For reactive energy or apparent energy, read Wh as varh or VAh.

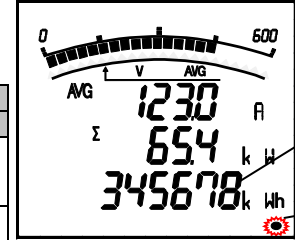

Active energy measurement value  
Metering status

The metering status blinks while the active energy is being counted. When active energy is not counted, turns OFF.

##### ■ Example Display

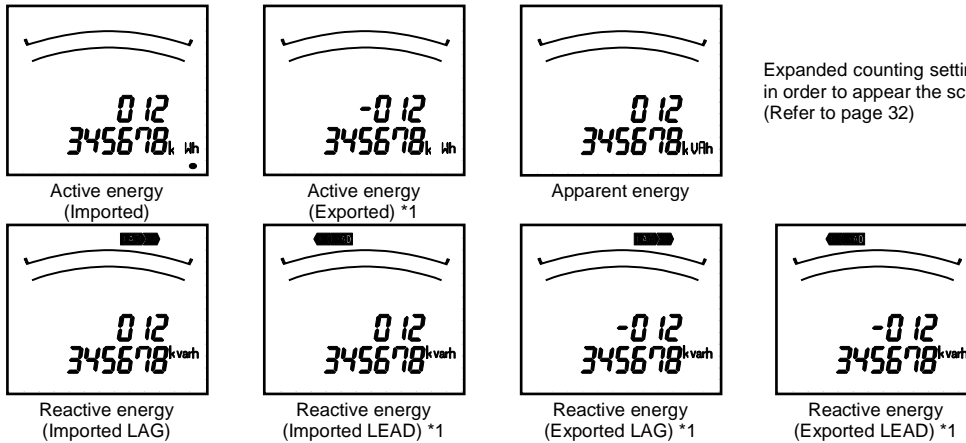

Expanded counting setting of menu 3 is necessary in order to appear the screen of \*1. (Refer to page 32)

#### ● How to change the unit of Wh, varh and VAh

When (+) and (-) are pressed simultaneously for 2 seconds, the unit of Wh, varh and VAh will be changed. This will enable to check the upper digits or lower digits of counts.

Example of change: Case of active energy (imported) = 012,345,678,901,234.567Wh

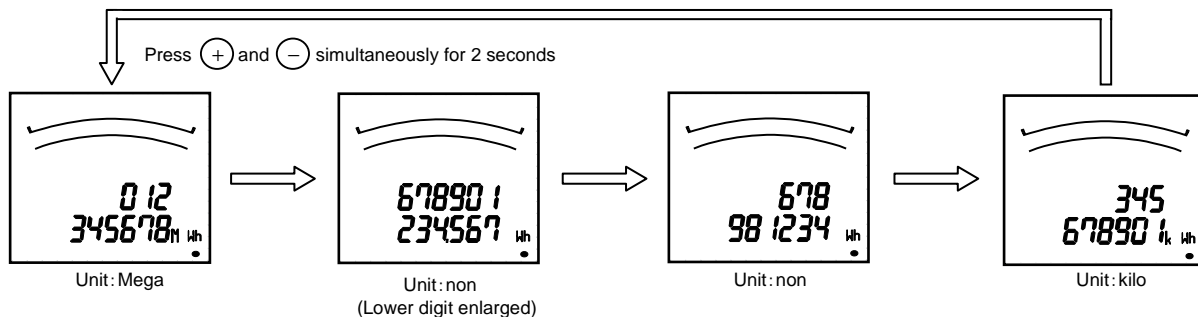

Note1: All of Wh, varh and VAh change to same unit even if these are not shown on the screen.

Note2: When the setting value of the VT primary voltage and the CT primary current are large, the lower digits less than a measurement range display "0".

#### ● Wh, varh and VAh zero reset

When (SET), (RESET), and (PHASE) are pressed simultaneously for 2 seconds, the measured values of Wh, varh and VAh will be reset.

When the password protection setting is enabled, Wh, varh and VAh are reset after you enter the password.

Also, you can clear all Wh, varh and VAh values by communication function. (In this case, the password is not necessary.)

Note 1: This is effective only in the instantaneous value display.  
 Note 2: All of Wh, varh and VAh will be reset even if these are not shown on the screen.  
 Note 3: The periodic active energy will not be reset. Another operation is necessary. (Refer to page 72)

## 5. Operation

### 5.1. Basic Operation

#### ● Reactive energy counting method (2 quadrant counting / 4 quadrant counting)

There are the following two types of quadrants for counting reactive energy.

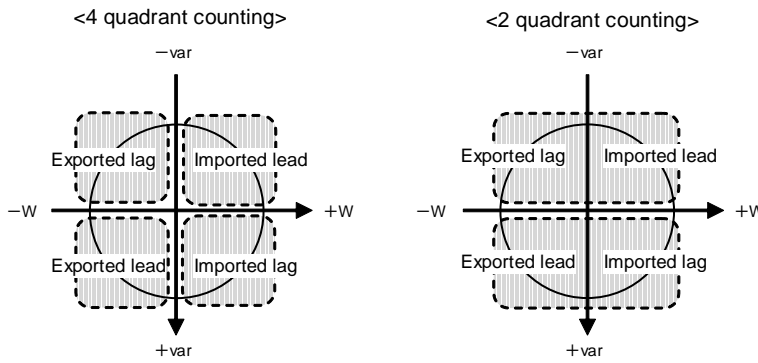

Counting method	Description
4 quadrant counting	It is counting (Imported lag), (Exported lead), (Imported lead) and (Exported lag) respectively as division of one. In general, it is counted by this method. However, at the boundary of each division, there is a dead region. It is suitable for the counting of equipment with the private electric generator.
2 quadrant counting	(Imported lag) and (Exported lead) are counted as division of one. (Imported lead) and (Exported lag) are counted as division of one. The dead region is made only nearby $\text{var}=0$ (power factor = 1). Therefore, because the dead region is not made nearby power factor = 0. It is suitable for the counting of equipment without the private electric generator and the reactive power of the capacitor load at the power factor = 0, generally.

The counting method for reactive energy (varh) is switched by “Expanded counting” in the Setting Menu 3.

Also, if setting of “IEC mode” in the Setting Menu 8 is ON, the counting method becomes 2 quadrant counting regardless of “Expanded counting” in the Setting Menu 3.

If setting of “Expanded counting” is selected for 4 quadrant counting and setting of “IEC mode” is ON, the screens of “exported lag” and “exported lag” appear, but these are not counting.

(Refer to page 32 about “Expanded counting” in the Setting Menu 3. Refer to page 47 about “IEC mode” in the Setting Menu 8.)

#### ● Each measurement item display during power transmission

The following table shows the symbol display ( $\pm$ ) for each measurement value according to the power reception /power sending status.

(Refer to page 32 about “Expanded counting” in the Setting Menu 3. Refer to page 47 about “IEC mode” in the Setting Menu 8.)

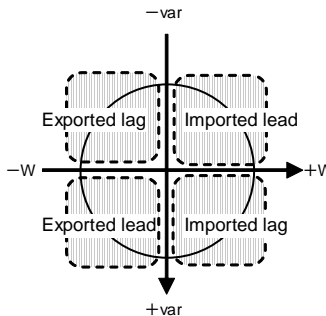

Quadrant		Measured items			
		Imported Lag	Imported Lead	Exported Lag	Exported Lead
A, DA, N-A, N-DA, V, Hz, VA HI, N-HI, HV		Unsigned			
W		Unsigned		“-”sign	
var	Normal mode (For 2 quadrant counting)	Unsigned LAG display※	“-”sign +I<LEAD display※	“-”sign -I<LEAD display※	Unsigned LAG display※
	Normal mode (For 4 quadrant counting)	Unsigned LAG display※	“-”sign +I<LEAD display※	Unsigned LAG display※	“-”sign +I<LEAD display※
	IEC mode (For 2 quadrant counting)	Unsigned LAG display※	“-”sign +I<LEAD display※	“-”sign -I<LEAD display※	Unsigned LAG display※
PF	Normal mode (For 2 quadrant counting)	Unsigned LAG display※	“-”sign +I<LEAD display※	“-”sign -I<LEAD display※	Unsigned LAG display※
	Normal mode (For 4 quadrant counting)	Unsigned LAG display※	“-”sign +I<LEAD display※	Unsigned LAG display※	“-”sign +I<LEAD display※
	IEC mode (For 2 quadrant counting)	Unsigned LAG display※	“-”sign +I<LEAD display※	Unsigned LAG display※	“-”sign +I<LEAD display※

※Turns on when displayed on the bar graph.

## 5. Operation

### 5.1. Basic Operation

#### ● Demand time and demand value of current demand

The demand time ( $t_0$ ) is the time until the measurement display value ( $I_0$ ) displays 95% of the input ( $I$ ) when a certain constant input ( $I$ ) is given. To display 100% of the input ( $I$ ), about three times more than the time ( $t_0$ ) is needed.

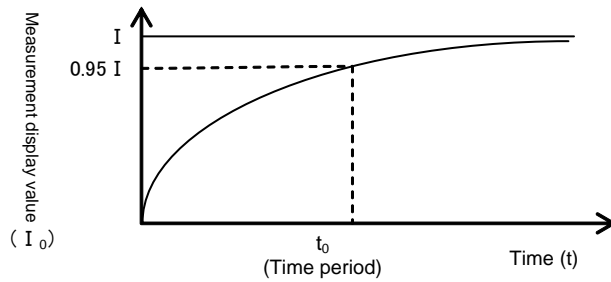

The demand value is the measurement display value with the above time characteristics, and it shows the overall average within the demand time.

The demand value changes over a relatively long time, so it is not affected by input changes within a short time.

Therefore, this is good for monitoring transformer overload.

## 5. Operation

### 5.2. Usage According to Purpose (Alarm, Periodic Active Energy, Rolling Demand, Operating Time, Password, etc.)

The following explains usage according to the purpose during operation.

#### ● Display and operation of the upper/lower limit alarm

When the value exceeds the upper or lower limit setting value set in advance, the display flickers and alarm can be output.  
(For more information about how to set the upper/lower limit alarm, refer to page 34 and after.)

##### ■ Alarm indicator

When the measurement element with an upper/lower limit alarm is displayed on the bar graph, "▲" flickers on the bar graph to indicate the upper/lower limit.

##### ■ Behavior During Alarm Generation

Alarm condition: When measurement value exceeds alarm value, display flicker and an alarm contact closes.

Alarm cancel: When alarm is canceled, display flickers normally and alarm contact opens.

Note: When the alarm delay time is set, an alarm is generated only when the alarm value is continuously beyond the upper/lower limit alarm value for the delay time.

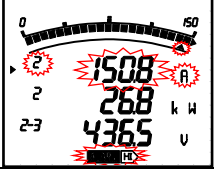
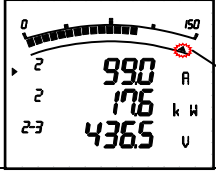
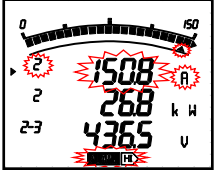
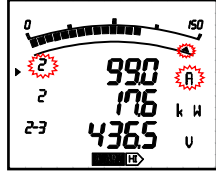
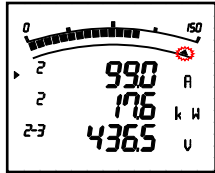
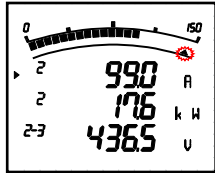
Alarm cancel method		Measurement value ≥ Upper limit value (or Measurement value ≤ Lower limit value)	Measurement value < Upper limit alarm value (or Measurement value > Lower limit alarm value)
Automatic (Auto)	Display	<b>ALARM</b> , <b>HI</b> or <b>LO</b> flickers 	Normal display  Upper/lower limit indicator
	Output (Alarm relay contact)	Closed	Opened
Manual (HoLd)	Display	<b>ALARM</b> , <b>HI</b> or <b>LO</b> flickers  (Alarm generation)	<b>ALARM</b> , <b>HI</b> or <b>LO</b> turns ON  (Alarm retention)
	Output (Alarm relay contact)	Closed	Closed
	Display	Normal display  (Alarm cancellation)	Normal display  (Alarm cancellation)
Output (Alarm relay contact)	Closed	Opened	Opened

Note 1: When the measurement element where the alarm generated exists on the display screen, the display for the digital value, unit (A, V, W, var, PF, Hz, %, DM, THD), and phase (1, 2, 3, N) will be based on the alarm status according to the following table. If it does not exist on the display screen, it does not flicker.

Alarm status	Digital value	Unit	Phase
Alarm generation	Flickering*	Flickering	Flickering*
Alarm retention	On	Flickering	Flickering*
Alarm cancellation	On	On	On

\* Does not flicker when displaying phases where no alarm occurred.

Note 2: When the backlight flickering setting is set to ON (flicker) during alarm generation, the backlight also flickers when an alarm is generated.

Note 3: On the maximum/minimum value display screen, the present value (middle of the digital display) and **ALARM**, **HI** or **LO** blinks.

##### ■ Monitoring phase for upper/lower limit alarm element

The phase that monitors the upper/lower limit alarm differs according to the measurement item. For more details, refer to the following table.

Upper/lower limit alarm element	Monitored phase			
	3-phase 4-wire	3-phase 3-wire (3CT, 2CT)	1-phase 3-wire (1N2)	1-phase 3-wire (1N3)
Upper limit current, current demand	1, 2, 3	1, 2, 3	1, N, 2	1, N, 3
Lower limit current, current demand	1, 2, 3	1, 2, 3	1, 2	1, 3
Upper limit N-phase current, N-phase current demand	N	—	—	—
Lower limit N-phase current, N-phase current demand	N	—	—	—
Upper limit voltage (L-L) (Note 1)	12, 23, 31	12, 23, 31	1N, 2N, 12	1N, 3N, 13
Lower limit voltage (L-L) (Note 1)	12, 23, 31	12, 23, 31	1N, 2N, 12	1N, 3N, 13
Upper limit voltage (L-N)	1N, 2N, 3N	—	—	—
Lower limit voltage (L-N)	1N, 2N, 3N	—	—	—
Upper limit active power, reactive power, power factor	Total	Total	Total	Total
Lower limit active power, reactive power, power factor	Total	Total	Total	Total
Upper limit frequency	1N	12	1N	1N
Lower limit frequency	1N	12	1N	1N
Harmonic current total RMS value	1, 2, 3	1, 2, 3 (note 2)	1, 2	1, 3
Harmonic current total RMS value N-phase	N	—	—	—
Harmonic voltage total distortion ratio	1N, 2N, 3N	12, 23	1N, 2N	1N, 3N
Upper limit rolling demand	Total	Total	Total	Total

Note1: For phase 12 (or phase 31) at 1-phase 3-wire, alarm monitoring is executed using a value that is two times the set upper/lower limit alarm value.

Note2: Only 3-phase 3-wire (3CT) is measured for the phase 2 harmonic current.



## 5. Operation

### 5.2 Usage According to Purpose (Alarm, Periodic Active Energy, Rolling Demand, Operating Time, Password, etc.)

#### ● Canceling the upper/lower limit alarm

The alarm cancellation method differs depending on the setting for alarm reset. The upper and lower limit alarms can be cancelled also via communication.

Alarm cancel method	Cancellation method
Automatic(Auto)	When the measurement value is below the upper/lower limit set value, the alarm is automatically reset.
Manual(HoLd)	<p>The alarm is maintained even after the measurement value is below the upper/lower limit set value. After the measurement value is below the upper/lower limit alarm value, operate the following alarm cancellation operation.            (Note: However, alarms cannot be cancelled from the maximum/minimum value display screen, or the digital input/output screen.)</p> <p>&lt;Cancelling alarms for selected elements&gt;            Display the element where the alarm generated, and then press <b>RESET</b> to cancel the alarm. When an element has a phase such as current and voltage, it is necessary to press <b>RESET</b> for each phase when cancelling an alarm.</p> <p>&lt;Cancelling alarms for all elements&gt;            At the current value display screen, press <b>RESET</b> for 2 seconds to cancel all alarms.</p>

Note: The difference of 0.8% between the maximum scale and alarm value is used for determining whether the measurement value is below the upper/lower limit alarm value in order to prevent chattering.

#### ● Stopping backlight flickering caused by upper/lower limit alarm generation

Press **RESET** the button to stop the backlight flickering.

#### ● Upper/lower limit alarm items on the alarm contacts

Setting		Alarm item for alarm output	
Contact output function 1	Contact output function 2	C1A and C1B terminals	C2A and C2B terminals
Alarm output	Alarm output	Alarm item 1	Alarm items 2-4 (output collectively with either of them)
Alarm output	Pulse output	Alarm items 1-4 (output collectively with either of them)	No alarm
Pulse output	Alarm output	No alarm	Alarm items 1-4 (output collectively with either of them)
Pulse output	Pulse output	No alarm	No alarm

#### ● Display of periodic active energy

The ability to measure the active energy divided into two time segments enables individual measurement of the active energy in a desired time segment such as peak/off-peak and day/night.

The periodic active energy is counting, even if the periodic active energy display setting is OFF.

(For the setting of the Periodic active energy display, refer to page 44.)

The time segments can be switched according to the setting via communication or the digital input (DI).

(The time segments cannot be switched manually (button operation).)

<p>&lt;For control via communication&gt;</p> <ul style="list-style-type: none"> <li>When the selected bit is ON (1), the active energy (Imported) is added to the periodic active energy n (where n = 1, 2).</li> <li>When the selected bit is OFF (0), the active energy (Imported) is not added to the periodic active energy n (where n = 1, 2).</li> </ul>
<p>&lt;For control from the digital input (DI)&gt;</p> <ul style="list-style-type: none"> <li>When there is no digital input (DI), the active energy (Imported) is added to the periodic active energy 1 and the active energy (Imported) is not added to the periodic active energy 2.</li> <li>When there is digital input (DI), the active energy (Imported) is not added to the periodic active energy 1 but the active energy (Imported) is added to the periodic active energy 2.</li> </ul>
<p>&lt;For setting without switching&gt;</p> <ul style="list-style-type: none"> <li>The active energy (Imported) is added to the periodic active energy 1 and periodic active energy 2. (No switching between time segments)</li> </ul>

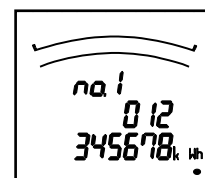

Periodic active energy 1

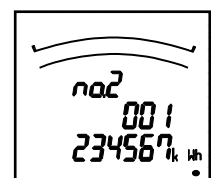

Periodic active energy 2

This is displayed when the **DISPLAY** button is pressed repeatedly in the operation mode to switch the measurement displays.

#### ● Resetting periodic active energy to zero

Showing the periodic active energy 1 or 2 on the display and holding down the **RESET** button for 2 seconds reset the periodic active energy to zero. (Only the displayed periodic active energy is reset.)

When the password protection setting is enabled, the periodic active energy is reset to zero after the password is entered. The periodic active energy can be individually or simultaneously reset to zero via communication. (In this case, the password is not necessary)

## 5. Operation

### 5.2 Usage According to Purpose (Alarm, Periodic Active Energy, Rolling Demand, Operating Time, Password, etc.)

#### ● Display and calculation of rolling demand

The rolling demand is the value obtained by dividing the active energy/reactive energy/apparent energy (\*1) in a specified time (interval) by the length of the interval.

The block interval demand is to select the time width (interval) of the "block" used for the demand calculation. (For setting of the rolling demand display, refer to page 44.)

##### ① Rolling block

The rolling block is to select the interval and sub-interval from 1- to 60-minute intervals (by minutes) and calculate and update the rolling demand at the end of each subinterval.

<Example when the interval is 15 minutes and the subinterval is 5 minutes>

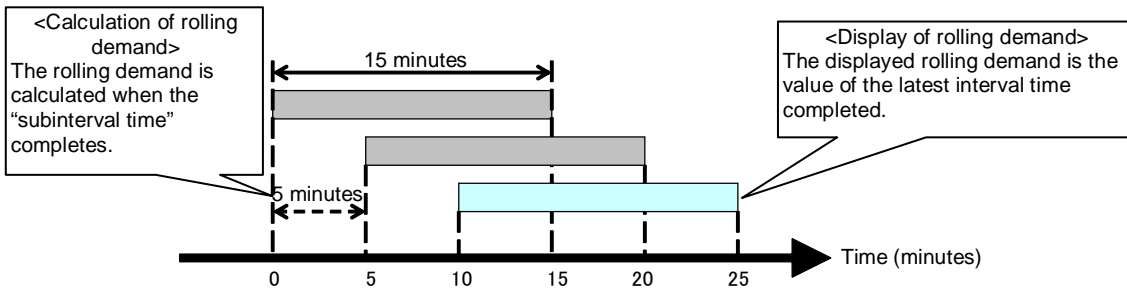

Note. Immediately after the adjusting rolling demand time is set, the demand time timer starts at "0 minute."

##### ② Fixing block

The fixing block is to select the interval from 1- to 60-minute intervals (by minutes) and calculate and update the rolling demand at the end of each interval. (For the fixing block, the interval time and subinterval time should be the same.)

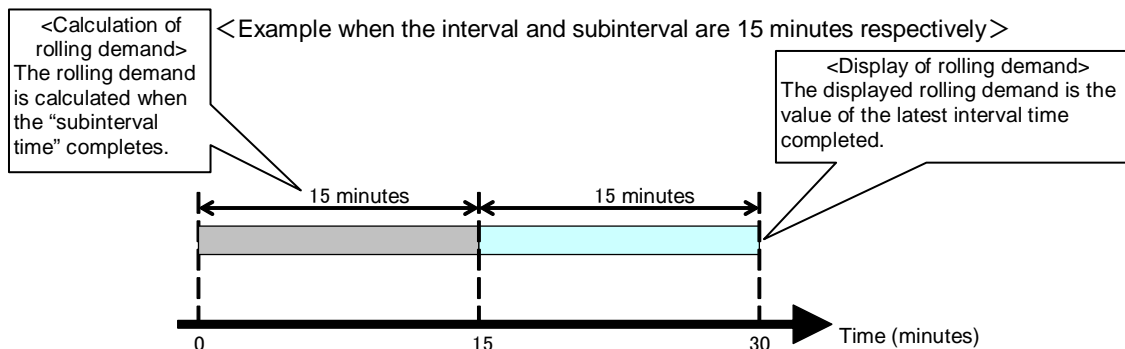

Note. Immediately after the adjusting rolling demand time is set, the demand time timer starts at "0 minute."

This is displayed when the **DISPLAY** button is pressed repeatedly in the operation mode to switch the measurement displays.

\*1: The energy counting used the calculation of the rolling demand are as follows.

Item	Setting of IEC mode		Remarks
	Normal mode	IEC mode	
Rolling demand W (DW)	Active energy(import)	Active energy(import) - Active energy(export)	
Rolling demand var (Dvar)	{Reactive energy(Imported lag) + Reactive energy(Exported lead)}	{Reactive energy(Imported lag) + Reactive energy(Exported lead)} -{Reactive energy(Exported lag) + Reactive energy(Imported lead)}	Refer to the below picture.
Rolling demand VA (DVA)	Apparent energy		

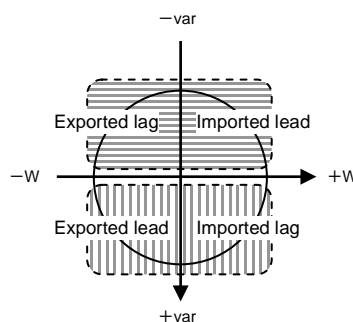

## 5. Operation

### 5.2 Usage According to Purpose (Alarm, Periodic Active Energy, Rolling Demand, Operating Time, Password, etc.)

#### ● Adjusting rolling demand time

Showing the rolling demand on the display and then holding down the (+) and (-) buttons at the same time for 2 seconds or more allows adjustment of the rolling demand time.

(Even if adjustment of the demand time is set to "Digital input," the demand time can be adjusted manually (by button operation).)

When the password protection setting is enabled, the demand time can be adjusted after the password is entered.

The rolling demand time can be adjusted also via communication although the setting item is not provided in the demand time adjustment setting. (In this case, the password is not necessary)

- Select "whether to adjust or not" the demand time.

no ← → yES  
(Not adjust) (Adjust)

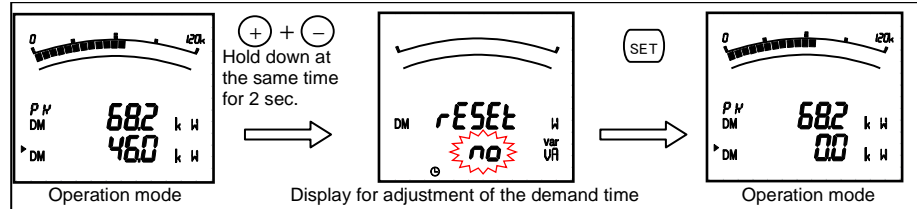

#### ● Resetting the peak value of rolling demand

Showing the rolling demand on the display and then holding down the (+) and (RESET) buttons at the same time for 2 seconds reset the peak value of rolling demand.

When the password protection setting is enabled, the peak value of rolling demand is reset after the password is entered. The rolling demand can be reset also via communication. (In this case, the password is not necessary)

#### ● Display of operation time

The measurement time is integrated according to the value set to the target for counting operation time (AUX, A, and V) and displayed as the load operation time.

To display the operation time, the operation time display setting should be configured in advance.

The operation time is counting, even if operation time display setting is OFF.

(For setting of the operation time display, refer to page 46.)

When the following set target for counting the operation time exceeds the threshold, the operation time 1 and operation time 2 are integrated.

Item	3-phase 4-wire	1-phase 2-wire	Others
AUX (Auxiliary power)	AUX	AUX	AUX
A (Current)	A <sub>AVG</sub>	A	A <sub>AVG</sub>
V (Voltage)	V <sub>AVG</sub> (L-N)	V	V <sub>AVG</sub> (L-L)

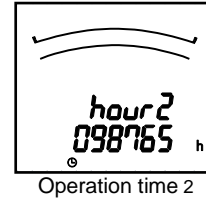
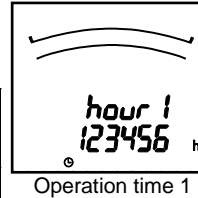

<Using the operation time 1 and operation time 2 as appropriate>

For example, if you want to check both of the operation time on a monthly basis (the value which is periodically reset) and the cumulative operation time from when the system started to operate (the value which is not periodically reset), use the operation time 1 and operation time 2 accordingly. If it is unnecessary to use the operation time 1 and operation time 2 at the same time, monitor either of them.

This is displayed when the (DISPLAY) button is pressed repeatedly in the operation mode to switch the measurement displays.

#### ● Resetting the operation time to zero

Showing the operation time 1 or the operation time 2 on the display and then holding down the (RESET) button for 2 seconds resets the operation time to zero.

(Only the displayed operation time is reset to zero.)

When the password protection setting is enabled, the operation time is reset to zero after the password is entered.

All the operation times can be reset to zero also via communication. (In this case, the password is not necessary)

## 5. Operation

### 5.2 Usage According to Purpose (Alarm, Periodic Active Energy, Rolling Demand, Operating Time, Password, etc.)

#### ● Display and operation of digital input/output status

The digital status can be displayed by inputting the switching signal of the breaker and the alarm signal of the over current relay to the digital input (DI) terminal.

The digital output (DO) terminal opens and closes the contact by communication control.

To display the digital input/output status, the digital input/output status display setting should be configured in advance. (For setting of the digital input/output display, refer to page 45.)

##### ■ Display examples

<When the optional plug-in module "ME-0052-SS96" is installed>

Digital input display (DI1 to DI5)

Digital output display (DO1, DO2)

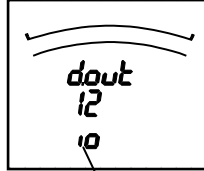
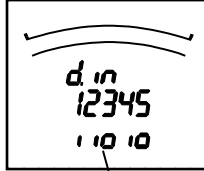

○ : Digital opened  
 ◐ : Digital closed

Digital input/ output status

These are displayed when the **DISPLAY** button is pressed repeatedly in the operation mode to switch the measurement displays.

##### ■ Digital input reset method

The method for maintaining the digital input status differs according to the digital input reset method.

Reset method	Cancellation method
Auto reset (Auto)	If the digital input turns OFF (Open), the digital input status automatically turns OFF (Open).
Latch (HoLd)	After it is detected that the digital input is ON (Closed), the digital input status is kept ON (Closed) until executing latch cancellation, even when the digital point input turns OFF (Open). (When alarm contact such as ACB are input, alarm generation status continues on this measurement instrument even when an alarm generation stops so that an alarm cannot be missed.)

##### ■ Digital input conditions

The following are the digital input conditions.

Input conditions	Terminals DI
Rating	24VDC (19 to 30VDC), 7mA or less
ON (Closed) / OFF (Open) time	30ms or longer for both ON and OFF

#### ● Releasing the digital input latch

Holding down the **RESET** button for 2 seconds while the digital input display (DI) is displayed releases the digital input (DI) latches collectively.

The digital input latches can be released also via communication.

#### ● Preventing maximum value update by motor starting current

When the motor current is monitored, use the motor starting current delay function to prevent maximum value update and alarm generation for the current, active power, reactive power, apparent Power, and power factor due to the motor starting current. It is necessary to set in advance to use the motor starting current delay function. (About settings, refer to page 36.)

##### ■ Movement when the motor starting current delay function is used

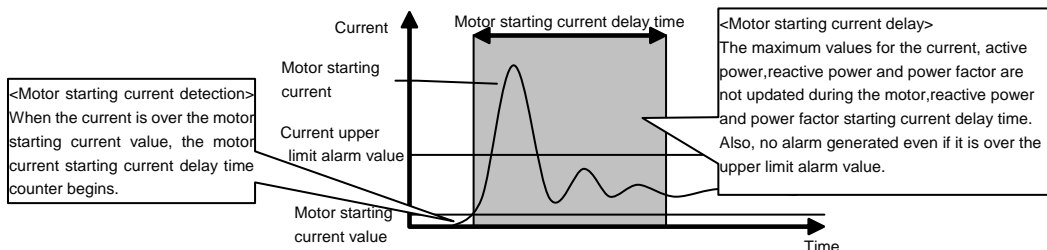

Note 1: Set the motor starting current value to a value lower than the lower limit value considering changes in the load current during operation.

Note 2: When the input current is below the motor starting current value, the minimum value update stops.

## 5. Operation

### 5.2 Usage According to Purpose (Alarm, Periodic Active Energy, Rolling Demand, Operating Time, Password, etc.)

#### ● Password protection setting

In the operation mode, after pressing **RESET** and **PHASE** simultaneously for 2 seconds or more, the password input display will be displayed. It is possible to set the password protection if you enter the password. Default password is "0000". If you enter the wrong password, to return to the password input display (the highest digit blink).

By pressing **DISPLAY** at the highest digit, to return to the operation mode.

If you enable password protection setting, you need to input password when performing the item of the following table.

#### ■ Password input

Password input display

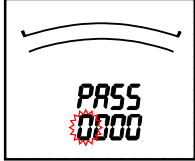

- Select a value of the blinking digit by pressing the **+** or **-** button from the highest digit.
- Pressing the **SET** button moves the setting digit (blinking digit) to a lower digit.
- Pressing the **DISPLAY** button moves the setting digit (blinking digit) to a higher digit.
- If you enter a correct password and pressing the **SET** in the lowest digit, password protection item is enabled.
- If you enter an incorrect password and pressing the **SET** in the lowest digit, to return to the highest digit.

#### ■ Password protection item

No.	Item
1	Shift to the setting mode
2	Clear the maximum/minimum value
3	Wh and varh, etc zero reset
4	Periodic Wh zero reset
5	Adjusting rolling demand time
6	Resetting the peak value of rolling demand
7	Clearing the operation time

#### ■ Password protection setting

(1) Set a password protection.

oFF ← → on  
(Not protected) (Protected)

(2) Change the password.

no ← → yES  
(Not change) (Change)

Note1. Select "no", and go back to the operation mode.

Note2. Select "yES", and the current password is displayed.

(3) Input a new password.

- Select a value of the blinking digit by pressing the **+** or **-** button from the highest digit.
- Pressing the **SET** button moves the setting digit (blinking digit) to a lower digit.
- Pressing the **DISPLAY** button moves the setting digit (blinking digit) to a higher digit.
- Pressing the **SET** button at the lowest digit saves the password.
- Setting is available in range from 0000 to 9999

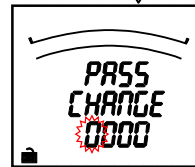
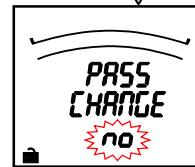
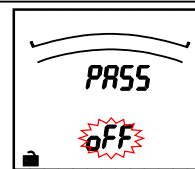

#### Important

If You Forget Your Password: It is not possible to cancel the password in the field. Please contact your supplier.



## 6. Other

### 6.1 Display Pattern Contents

[For others except 3-phase 4-wire]

Display pattern	Screen set by display pattern						Additional display (Set in the setting menus 3, 7, 8)																	
	No.1	No.2	No.3	No.4	No.5	No.6	No.7	No.8	No.9	No.10	No.11	No.12	No.13	No.14	No.15	No.16	No.17	No.18	No.19	No.20	No.21	No.22	No.23	No.24
	Wh	Wh Exported	varh Imported (LAG)	varh Imported (LEAD)	varh Exported (LAG)	varh Exported (LEAD)	VAh	Periodic Wh1	Periodic Wh2	Rolling demand DW	Rolling demand Dvar	Rolling demand VAW	Harmonic current	Harmonic voltage	DI status	DO status	Operation time1	Operation time2						
P01	Upper	A	A	A										—	—	—			Degree	Degree	DI	DO	—	—
	Middle	W	W	PF										Periodic Wh1	Periodic Wh2	Peak Value Demand value	Peak Value Demand value	Peak Value Demand value	Distortion ratio RMS value	Distortion ratio RMS value	DI No.	DO No.	hour1	hour2
	Lower	V	PF	V																	RMS value	RMS value	status	Operation time
P02	Upper	A	A	A			—	—																
	Middle	V	W	PF			Wh	Wh Exported						ditto	ditto	ditto	ditto	ditto	ditto	ditto	ditto	ditto	ditto	ditto
	Lower	Wh	Wh	Wh																				
P03	Upper	A	A	A	A	A																		
	Middle	PF	PF	PF	PF	PF								ditto	ditto	ditto	ditto	ditto	ditto	ditto	ditto	ditto	ditto	ditto
	Lower	V	W	var	VA	Hz																		
P04	Upper	A	A	A	A	A	—	—	—	—	—	—												
	Middle	V	W	var	VA	PF	Hz	Wh	Wh Exported	varh Imported (LAG)	varh Imported (LEAD)	varh Exported (LAG)	varh Exported (LEAD)	VAh	ditto	ditto	ditto	ditto	ditto	ditto	ditto	ditto	ditto	ditto
	Lower	Wh	Wh	varh	VAh	Wh	Wh																	
P05	Upper	PF	Hz	VA																				
	Middle	W	W	W										ditto	ditto	ditto	ditto	ditto	ditto	ditto	ditto	ditto	ditto	ditto
	Lower	var	var	var																				
P06	Upper	A1	V12	A																				
	Middle	A2	V23	—										ditto	ditto	ditto	ditto	ditto	ditto	ditto	ditto	ditto	ditto	ditto
	Lower	A3	V31	V																				
P07	Upper	A	A1	V12																				
	Middle	V	A2	V23										ditto	ditto	ditto	ditto	ditto	ditto	ditto	ditto	ditto	ditto	ditto
	Lower	W	A3	V31																				
P08	Upper	A	A	A1	V12		—	—																
	Middle	V	W	A2	V23		Wh	Wh Exported						ditto	ditto	ditto	ditto	ditto	ditto	ditto	ditto	ditto	ditto	ditto
	Lower	Wh	Wh	A3	V31																			
P09	Upper	A	A1	DA1	V12																			
	Middle	DA	A2	DA2	V23									ditto	ditto	ditto	ditto	ditto	ditto	ditto	ditto	ditto	ditto	ditto
	Lower	V	A3	DA3	V31																			
P10	Upper	A	A	A1	DA1	V12																		
	Middle	DA	DA	A2	DA2	V23								ditto	ditto	ditto	ditto	ditto	ditto	ditto	ditto	ditto	ditto	ditto
	Lower	V	W	A3	DA3	V31																		
P11	Upper	A	A	DA1	V12		—	—																
	Middle	DA	V	DA2	V23		Wh	Wh Exported						ditto	ditto	ditto	ditto	ditto	ditto	ditto	ditto	ditto	ditto	ditto
	Lower	Wh	Wh	DA3	V31																			
P12	Upper	A	A	A	DA	W																		
	Middle	DA	W	V	V	V								ditto	ditto	ditto	ditto	ditto	ditto	ditto	ditto	ditto	ditto	ditto
	Lower	Wh	Wh	Wh	Wh	Wh		Wh	Wh Exported															
P13	Upper	A1	V12	W	V	V	V	—	—	—	—	—	—											
	Middle	A2	V23	var	Hz	Hz	VA	Wh	Wh Exported	varh Imported (LAG)	varh Imported (LEAD)	varh Exported (LAG)	varh Exported (LEAD)	VAh	ditto	ditto	ditto	ditto	ditto	ditto	ditto	ditto	ditto	ditto
	Lower	A3	V31	PF	Wh	varh	VAh																	
P00	Upper	Arbitrary	Arbitrary	Arbitrary	Arbitrary																			
	Middle	Arbitrary	Arbitrary	Arbitrary	Arbitrary		Wh	Wh Exported	varh Imported (LAG)	varh Imported (LEAD)	varh Exported (LAG)	varh Exported (LEAD)	VAh	ditto	ditto	ditto	ditto	ditto	ditto	ditto	ditto	ditto	ditto	ditto
	Lower	Arbitrary	Arbitrary	Arbitrary	Arbitrary																			

Note 1: When an additional screen is added, a screen number is added.

Note 2: When 1-phase 2-wire, only phase1 (A1, DA1) is displayed for current and only phase12 (V12) is displayed for voltage. Other phases are not displayed even when they are set in the display pattern.

Note 3: The phases displayed in the display patterns of the above table are displayed on the screen according to the phase wire system setting shown in the table below.

Phase display in the table above	phase wire		1-phase 2-wire	1-phase 3-wire (1N2)	1-phase 3-wire (1N3)	3-phase 3-wire
	1	2				
Current	1	2	Phase not displayed	1	1	1
	2	3	Measurement not displayed	N	N	2
	3	12	Measurement not displayed	2	3	3
Voltage	12	23	Phase not displayed	1N	1N	12
	23	31	Measurement not displayed	2N	3N	23
	31		Measurement not displayed	12	13	31

Note 4: In the table, "Wh" indicates Imported active energy, and "varh" indicates Imported reactive energy (lag).

Note 5: When Wh or varh is selected at the screen of from No.1 to No.4, the additional display of Wh or varh appears. (P00)

## 6. Other

### 6.2. Maximum Scale Value

Settable primary voltage, primary current, and standard maximum scale value are shown in the tables below.

#### ●Maximum scale value of each item

Measurement element		Maximum scale value	
Current, Current demand		Setting of current maximum scale =SP.	
Voltage		CT Primary current	
		VT Primary current	
In the case with VT (Note 2)	1-phase 2-wire, 3-phase 3-wire	VT Primary voltage (Phase voltage)×150/110	
	3-phase 4-wire	VT Primary voltage (Line voltage)×150/110	
At direct input	1-phase 2-wire, 3-phase 3-wire	110V	150V
		220V	300V
		440V	600V
	1-phase 3-wire (Phase voltage / Line voltage)	110/220V	150V/300V
		220/440V	300V/600V
	3-phase 4-wire (Phase voltage / Line voltage)	63.5/110V	100/150V
		100/173V, 110/190V	150/300V
		220/380V, 230/400V, 240/415V, 254/440V	300/600V
		277/480V	400/640V
	Active power, Rolling demand W (Note 1)		VT ratio×CT ratio ×specific power(100%)kW
Reactive power, Rolling demand var (Note 1)		VT ratio×CT ratio ×specific power(100%)kvar	
Apparent power, Rolling demand VA (Note 1)		VT ratio×CT ratio ×specific power(100%)kVA	

Note1: At direct voltage setting, VT ratio = 1. The specific power is according to the table on the right.

Note2: For convenience of scale, this is rounded off to the nearest whole number.

#### ●Specific power value for scale calculation

Phase line type	CT Secondary	Rated voltage	Specific power value (100%)		
1-phase 2-wire	5A	At direct input (Line voltage)	110V	0.5kW	
			220V	1.0kW	
		440V	2.0kW		
	1A	In the case with VT (Line voltage)	100V, 110V	0.5kW	
			220V	1.0kW	
		At direct input (Line voltage)	110V	0.1kW	
1-phase 3-wire	5A	Without VT (Line voltage)	220V	1.0kW	
			440V	2.0kW	
		1A	220V	0.2kW	
	3-phase 3-wire	5A	At direct input (Line voltage)	110V	1.0kW
				220V	2.0kW
			440V	4.0kW	
1A		In the case with VT (Line voltage)	100V, 110V	1.0kW	
			220V	2.0kW	
		At direct input (Line voltage)	110V	0.2kW	
3-phase 4-wire	5A	At direct input	63.5/110V	1.0kW	
			100/173V, 110/190V	2.0kW	
			220/380V, 230/400V, 240/415V, 254/440V	4.0kW	
		In the case with VT (Phase voltage)	277/480V	5.0kW	
			63.5V	1.0kW	
			100V, 110V, 115V, 120V	2.0kW	
	1A	At direct input	63.5/110V	0.2kW	
			100/173V, 110/190V	0.4kW	
			220/380V, 230/400V, 240/415V, 254/440V	0.8kW	
		In the case with VT (Phase voltage)	277/480V	1.0kW	
			63.5V	0.2kW	
			100V, 110V, 115V, 120V	0.4kW	

Note: For reactive power or apparent power, read kW of above as kvar or kVA.



## 6. Other

### 6.3. Possible Setting Range for Maximum Scale

The maximum scale of current can be selected from about 40% to 120% of rating, and maximum scale of voltage can be selected from about 20% to 250% of rating, and maximum scale of active power and reactive power can be selected from about 20% to 120% of rating. But for the convenience of scale conditions, the values in the following tables are applied. Also, this is same as with corresponding measured values for maximum scale of analog output.

#### ■ Current maximum scale value

Possible setting range:-10 STEP to +3STEP of the rating

Example: When the rating is 100A, the value is from 45A to 160A.

Current maximum scale value (1/3)

STEP	A unit
1	1A
2	1.2A
3	1.5A
4	1.6A
5	1.8A
6	2A
7	2.2A
8	2.4A
9	2.5A
10	3A
11	3.2A
12	3.6A
13	4A
14	4.5A
15	4.8A
16	5A
17	6A
18	6.4A
19	7.2A
20	7.5A
21	8A
22	9A
23	9.6A
24	10A
25	12A
26	15A
27	16A
28	18A
29	20A
30	22A
31	24A
32	25A
33	30A
34	32A
35	36A
36	40A
37	45A
38	48A
39	50A
40	60A
41	64A
42	72A
43	75A
44	80A
45	90A
46	96A
47	100A
48	120A
49	150A
50	160A

Current maximum scale value (2/3)

STEP	A unit	kA unit
51	180A	
52	200A	
53	220A	
54	240A	
55	250A	
56	300A	
57	320A	
58	360A	
59	400A	
60	450A	
61	480A	
62	500A	
63	600A	
64	640A	
65	720A	
66	750A	
67	800A	
68	900A	
69	960A	
70	1000A	
71	1200A	
72	1500A	
73	1600A	
74	1800A	
75	2000A	
76	2200A	
77	2400A	
78	2500A	
79	3000A	
80	3200A	
81	3600A	
82	4000A	
83	4500A	
84	4800A	
85	5000A	
86	6000A	
87	6400A	
88	7200A	
89	7500A	
90	8000A	
91		9kA
92		9.6kA
93		10kA
94		12kA
95		15kA
96		16kA
97		18kA
98		20kA
99		22kA
100		24kA

Current maximum scale value (3/3)

STEP	kA unit
101	25kA
102	30kA
103	32kA
104	36kA
105	40kA

## 6. Other

### 6.3 Possible Setting Range for Maximum Scale

#### ■ Voltage maximum scale value

Possible setting range:-18 STEP to +10STEP of the standard maximum scale value.

Example: When the standard maximum scale value is 100V, the value is from 20V to 320V.

Voltage maximum scale value (1/3)

STEP	V unit
1	15V
2	16V
3	18V
4	20V
5	22V
6	24V
7	25V
8	30V
9	32V
10	36V
11	40V
12	45V
13	48V
14	50V
15	60V
16	64V
17	72V
18	75V
19	80V
20	90V
21	96V
22	100V
23	120V
24	150V
25	160V
26	180V
27	200V
28	220V
29	240V
30	250V
31	300V
32	320V
33	360V
34	400V
35	450V
36	480V
37	500V
38	600V
39	640V
40	720V
41	750V
42	800V
43	900V
44	960V
45	1000V
46	1200V
47	1500V
48	1600V
49	1800V
50	2000V

Voltage maximum scale value (2/3)

STEP	V unit	kV unit
51	2200V	
52	2400V	
53	2500V	
54	3000V	
55	3200V	
56	3600V	
57	4000V	
58	4500V	
59	4800V	
60	5000V	
61	6000V	
62	6400V	
63		7.2kV
64		7.5kV
65		8kV
66		9kV
67		9.6kV
68		10kV
69		12kV
70		15kV
71		16kV
72		18kV
73		20kV
74		22kV
75		24kV
76		25kV
77		30kV
78		32kV
79		36kV
80		40kV
81		45kV
82		48kV
83		50kV
84		60kV
85		64kV
86		72kV
87		75kV
88		80kV
89		90kV
90		96kV
91		100kV
92		120kV
93		150kV
94		160kV
95		180kV
96		200kV
97		220kV
98		240kV
99		250kV
100		300kV

Voltage maximum scale value (3/3)

STEP	kV unit
101	320kV
102	360kV
103	400kV
104	450kV
105	480kV
106	500kV
107	600kV
108	640kV
109	720kV
110	750kV
111	800kV
112	900kV
113	960kV
114	1000kV
115	1200kV
116	1500kV
117	1600kV
118	1800kV
119	2000kV
120	2200kV

## 6. Other

### 6.3 Possible Setting Range for Maximum Scale

#### ■ Maximum scale value for active power / reactive power

Possible setting range:-18 STEP to +3STEP of the rating

Example: When the rating is 1000W, the value is from 200W to 1600W.

Maximum scale value of active power (1/5)

STEP	W unit
1	8W
2	9W
3	9.6W
4	10W
5	12W
6	15W
7	16W
8	18W
9	20W
10	22W
11	24W
12	25W
13	30W
14	32W
15	36W
16	40W
17	45W
18	48W
19	50W
20	60W
21	64W
22	72W
23	75W
24	80W
25	90W
26	96W
27	100W
28	120W
29	150W
30	160W
31	180W
32	200W
33	220W
34	240W
35	250W
36	300W
37	320W
38	360W
39	400W
40	450W
41	480W
42	500W
43	600W
44	640W
45	720W
46	750W
47	800W
48	900W
49	960W
50	1000W

Maximum scale value of active power (2/5)

STEP	W unit	kW unit
51	1200W	
52	1500W	
53	1600W	
54	1800W	
55	2000W	
56	2200W	
57	2400W	
58	2500W	
59	3000W	
60	3200W	
61	3600W	
62	4000W	
63	4500W	
64	4800W	
65	5000W	
66	6000W	
67	6400W	
68	7200W	
69	7500W	
70	8000W	
71		9kW
72		9.6kW
73		10kW
74		12kW
75		15kW
76		16kW
77		18kW
78		20kW
79		22kW
80		24kW
81		25kW
82		30kW
83		32kW
84		36kW
85		40kW
86		45kW
87		48kW
88		50kW
89		60kW
90		64kW
91		72kW
92		75kW
93		80kW
94		90kW
95		96kW
96		100kW
97		120kW
98		150kW
99		160kW
100		180kW

Maximum scale value of active power (3/5)

STEP	kW unit	MW unit
101	200kW	
102	220kW	
103	240kW	
104	250kW	
105	300kW	
106	320kW	
107	360kW	
108	400kW	
109	450kW	
110	480kW	
111	500kW	
112	600kW	
113	640kW	
114	720kW	
115	750kW	
116	800kW	
117	900kW	
118	960kW	
119	1000kW	
120	1200kW	
121	1500kW	
122	1600kW	
123	1800kW	
124	2000kW	
125	2200kW	
126	2400kW	
127	2500kW	
128	3000kW	
129	3200kW	
130	3600kW	
131	4000kW	
132	4500kW	
133	4800kW	
134	5000kW	
135	6000kW	
136	6400kW	
137	7200kW	
138	7500kW	
139	8000kW	
140		9MW
141		9.6MW
142		10MW
143		12MW
144		15MW
145		16MW
146		18MW
147		20MW
148		22MW
149		24MW
150		25MW

Maximum scale value of active power (4/5)

STEP	MW unit
151	30MW
152	32MW
153	36MW
154	40MW
155	45MW
156	48MW
157	50MW
158	60MW
159	64MW
160	72MW
161	75MW
162	80MW
163	90MW
164	96MW
165	100MW
166	120MW
167	150MW
168	160MW
169	180MW
170	200MW
171	220MW
172	240MW
173	250MW
174	300MW
175	320MW
176	360MW
177	400MW
178	450MW
179	480MW
180	500MW
181	600MW
182	640MW
183	720MW
184	750MW
185	800MW
186	900MW
187	960MW
188	1000MW
189	1200MW
190	1500MW
191	1600MW
192	1800MW
193	2000MW
194	2200MW
195	2400MW
196	2500MW
197	3000MW
198	3200MW
199	3600MW
200	4000MW

Maximum scale value of active power (5/5)

STEP	MW unit
201	4500MW
202	4800MW
203	5000MW
204	6000MW
205	6400MW
206	7200MW
207	7500MW
208	8000MW

Note: For reactive power or apparent power, read kW of above as kvar or kVA.



## 6. Other

### 6.5. Measurement Characteristic

#### ■ Metering actions in other than operation mode

Status	Measurement	Display	Analog output	Alarm contact point	Pulse output
Several seconds just after turning on the auxiliary power supply (Backlight is lit, and LCD is not lit.)	No measurement	No display	Output over about 100% may be made until internal voltage becomes stable.	Opened	No output
Setting mode, Set value confirmation mode Password protection mode	Same actions as in operation mode	No display of measured value	Same actions as in operation mode	Status before getting into setting mode and set value confirmation mode is kept.	Same actions as in operation mode
During power failure	No measurement	No display	No output	Opened	No output

#### ■ Metering actions in input status

Measurement items	Actions	
Current (A) Current demand (DA)	0A when the input current is less than 0.005A	When it is over the upper limit of the possible display range (9999), the upper limit of the possible display range (9999) is displayed.
Voltage (V)	0V when the input voltage (line voltage) is less than 11V. For 3-phase 4-wire, 0V when the line to neutral voltage is less than 11V or the line to line voltage is less than 19V. For 1-phase 3-wire, 0V when the voltage between P1-P3 is less than 22V.	When it is over the upper limit of the possible display range (9999), the upper limit of the possible display range (9999) is displayed. (Note 2)
Active power (W) Reactive power (var) Apparent power (VA)	0W, 0var and 0VA for total when the current and the voltage are 0A and 0V for all 3 phases. 0W, 0var and 0VA for each phase when the current of phase n is 0A or the voltage of phase n is 0V. (where n = 1,2 or 3)	When it is over the upper limit of the possible display range (9999), the upper limit of the possible display range (9999) is displayed.
Power factor (PF)	1.0 for total when the current and the voltage are 0A and 0V for all 3 phases. 1.0 for each phase when the current of phase n is 0A or the voltage of phase n is 0V. (where n = 1,2 or 3)	
Frequency (Hz)	When the input voltage of phase1 is low voltage, ---- will be displayed. Input 22V or more.	When the frequency is less than 44.5Hz or over 99.9Hz, ---- is displayed.
Harmonic current (HI)	For effective value measurement : When the current is 0A, 0A is displayed. (Each phase) : When the voltage of phase1 is 0V or the frequency is less than 44.5Hz, ---- is displayed for all phases.	For content factor measurement : When the 1st current harmonic is 0A, 0% is displayed. (Each phase) : When the voltage of phase1 is 0V or the frequency is less than 44.5Hz, ---- is displayed for all phases
Harmonic Voltage (HV)	For effective value measurement : When the current is 0V, 0V is displayed. (Each phase) : When the voltage of phase1 is 0V or the frequency is less than 44.5Hz, ---- is displayed for all phases.	For content factor measurement : When the voltage is 0V, 0% is displayed. (Each phase) : When the voltage of phase1 is 0V or the frequency is less than 44.5Hz, ---- is displayed for all phases
Operating Time	999999 hour is displayed if it is over 999999.	

Note1: Input current and input voltage means the input to the instrument. They are not to primary sides of VT, CT.

Note2: For direct measurement, it does not input upper maximum scale value.



#### ■ Analog output action

Output setting	Output range
Output limit setting is "ON"	-1% to 101% of span
Output limit setting is "OFF"	-5% to 105% of span

## 6. Other

### 6.6. Troubleshooting

In the case of abnormal noise, odor, smoke, or heat generation from this instrument, turn it off at once. Check the followings before you ask for repair.

	Condition	Possible cause	Solution
Display	The display is not lit.	Auxiliary power supply is not impressed on MA and MB terminals.	Impress auxiliary power supply.
	When the auxiliary power supply is impressed, display is not lit soon.	This is not an error. For about a few seconds after auxiliary power source is charged, initialization of internal circuit is carried out.	Use it as it is.
	The back light is not lit.	The back light may be set to auto off (Auto). (If it turns on after you press an operation button, it means the backlight is set to auto off.)	When the auto off is enabled, it automatically turns off in 5 minutes. Continue using it as it is or change the setting to HoLd (it stays on). (Refer to page 33)
	The display becomes black.	It may become black owing to static electricity.	It goes off after a while.
	"End" display remains.	The product is still in the setting mode.	Press  .
Measurement error	The current and voltage have large errors.	The settings for VT / direct voltage and CT primary current may be incorrect.	Please check the set values for VT / direct voltage and CT primary current.
	The current and voltage are correct, but the active power, reactive power, and power factor have large errors.	The wiring for VT/CT or for the measurement instrument may be incorrect.	Please check the wiring for VT/CT and for the measurement instrument.
	Measured values of PF are including large error.	If the input current is smaller than the rating, error becomes large. (about 5% or below of rated current)	This is not an error, or uses it as it is, or if error is troublesome, changes the CT according to the actual current to be used.
	The displayed active power is different from the active power that is calculated by multiplying the displayed current, voltage, and power factor.	If the AC of the current and voltage deteriorate due to harmonics, it will not be the same as the calculated value. (For AC without harmonics, the calculated value will match with the displayed value.)	Please continue using the instrument as it is.
	The total effective harmonics value from the harmonic current is very different from the current value.	The distortion factor (content factor) is way over 100%. (Such as measurement of the inverter secondary side output)	Please check the measured item.
	The current measured by another measurement instrument (such as a clamp meter) is different from the current measured by this instrument. (More than the tolerance)	If another measurement instrument uses the average method for measuring, the measurement instrument used will have a larger error when the AC deteriorates due to harmonics. (This measurement instrument uses the RMS value method.)	Please compare the currents using a measurement instrument that uses the RMS value method.
	Analog output has a large error.	If the wiring to the receptor is long, the error may increase.	Perform the zero and span adjustment for analog output. (Refer to page 60.)
	Pulse output has a large error.	When the pulse unit is set to the minimum value and the pulse width is set to 0.500s or 1.000s, the pulse output cannot follow if the load is too large, which can result in a decrease in the pulse output number.	Review the pulse unit or pulse width setting (refer to pages 38).
On the maximum/minimum value display screen, a present value that is outside of the maximum/minimum range is displayed.	During the starting current delay time, the maximum value is not updated, so the present value that is over the maximum value may be displayed.	Please continue using the instrument as it is.	
Operation	Cannot change the settings in the setting mode.	If  at the bottom of the screen is blinking, you are in the set value confirmation mode. Settings cannot be changed in this mode.	Please go to the setting mode to change settings.
	"PASS 0000" appears when trying to change the setting mode.	The password protection setting is turned to valid.	Please enter the set password. Also, the default password is "0000" (Refer to page 76)
Other	Maximum value and minimum value changed.	These are cleared if the settings for the phase wire, VT/direct voltage, and CT primary current are changed.	Make a note of the values before changing the settings
	The values of the setting items that were not supposed to change have changed.	Some setting items return to the default values when settings for the phase wire method, VT/direct voltage, and CT primary current are changed.	Please refer to "Initializing Related Items by Changing Settings" (page 51) and reconfigure the setting items that returned to their default values.
	"PASS 0000" appears when trying to clear the energy or maximum/minimum value.	The password protection setting is turned to valid.	Please enter the set password. Also, the default password is "0000" (Refer to page 76)

## 6. Other

### 6.6 Troubleshooting

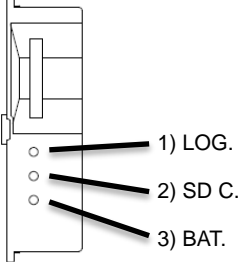
	Condition	Possible cause	Solution
Communication or Logging	COM in the LCD screen is blinking. (Appears for 0.25sec. / Disappears for 0.25sec.)	MODBUS RTU® communication error as follows was detected. <ul style="list-style-type: none"> <li>• Communication setting(Slave address, baud rate, stop bit and parity) was incorrect.</li> <li>• Function code was incorrect.</li> <li>• Register address was incorrect. etc.</li> </ul>	Review the communication setting, the function code and the register address and so on. If the correct query received, COM is lit.
	COM in the LCD screen is blinking. (Appears for 1sec. / Disappears for 1sec.)	When using ME-0000MT-SS96, MODBUS TCP® communication error as follows was detected. <ul style="list-style-type: none"> <li>• MODBUS TCP® application protocol header was incorrect.</li> <li>• Function code was incorrect.</li> <li>• Register address was incorrect. etc.</li> </ul>	Review the MODBUS TCP® application protocol header, the function code and the register address and so on. If the correct query received, COM is lit.
		When using ME-0000BU-SS96, the error as follows was detected. <ul style="list-style-type: none"> <li>• Setting value set from the SD card was incorrect.</li> <li>• SD memory card error.</li> <li>• The battery is low voltage. etc.</li> </ul>	Check the LEDs of ME-0000BU-SS96.  <ol style="list-style-type: none"> <li>1) LOG. LED is blink quickly. When Setting of Logging-item pattern is LP00, Setting data file needed to store in SD memory card was incorrect. Review the setting data file in SD memory card.</li> <li>2) SD C. LED is blink quickly. Check whether the SD memory card is write-protect and SD memory card capacity is sufficient or not.</li> <li>3) BAT. LED is lit. The voltage of the embedded lithium battery becomes low. It is impossible for customer to exchange the battery. Please consider renewal.</li> </ol>

**ME96SSRA-MB**

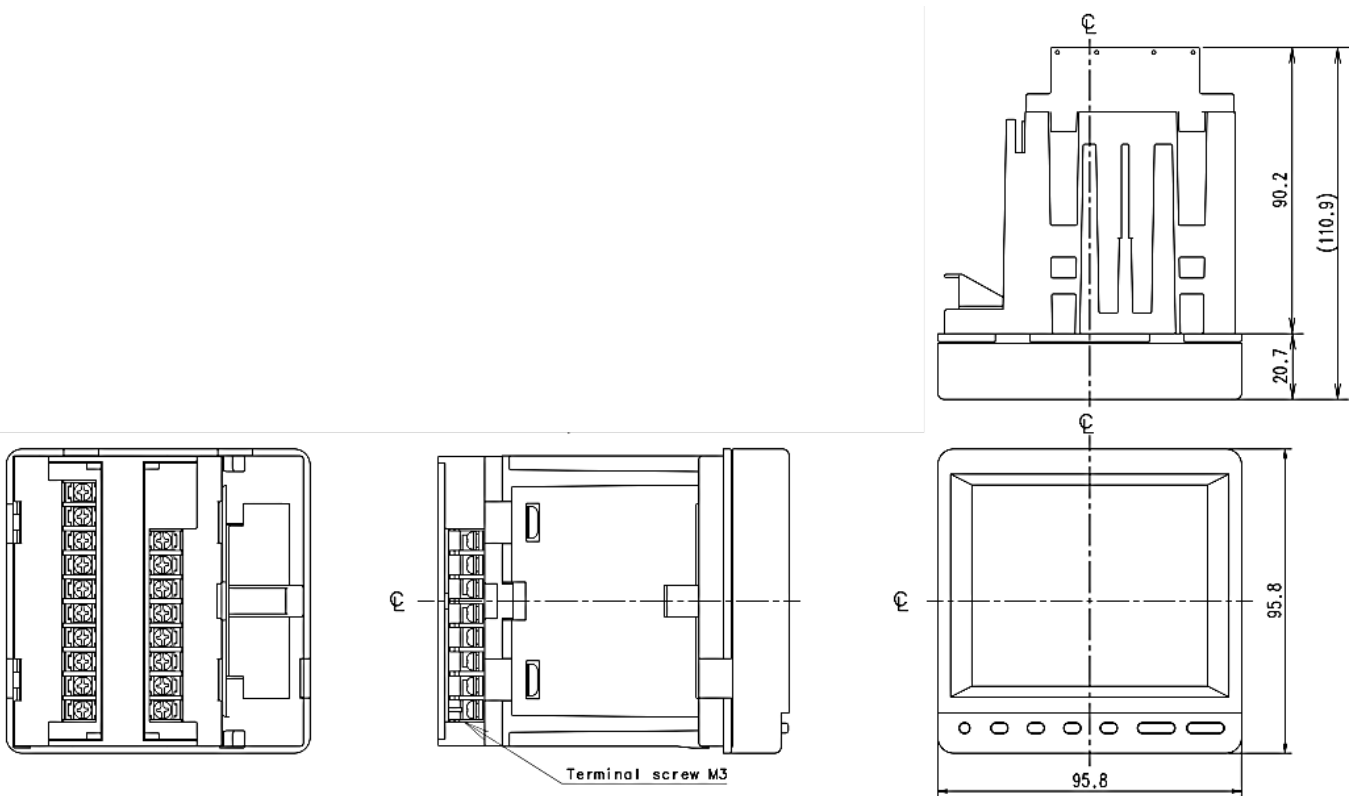

**Optional Plug-in Module**

- ME-4210-SS96**
- ME-0040C-SS96**
- ME-0052-SS96**

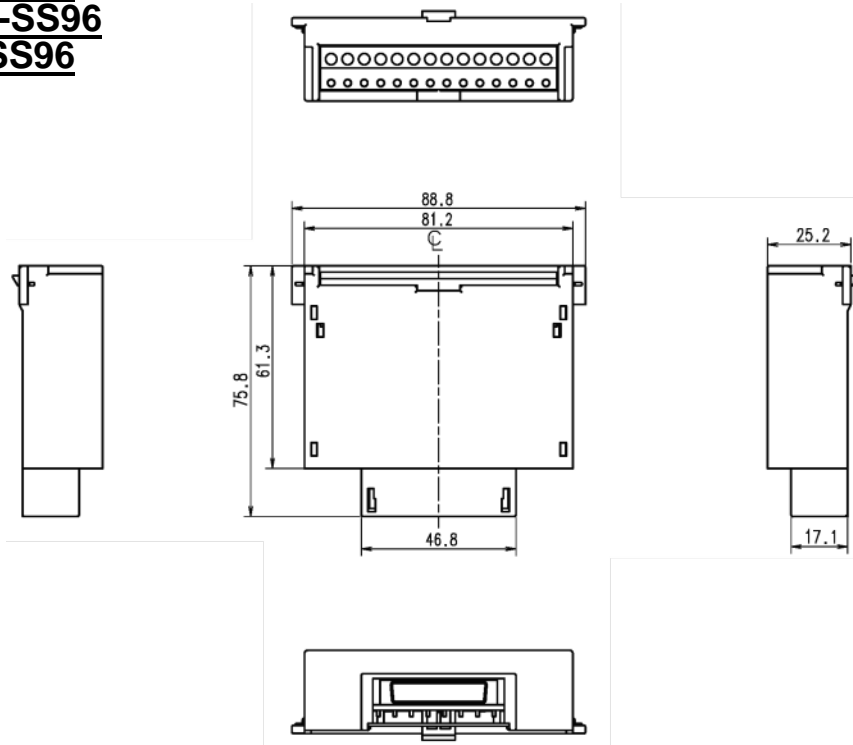



**Installation 1. Dimensions**

**Optional Plug-in Module**  
**ME-0000MT-SS96**

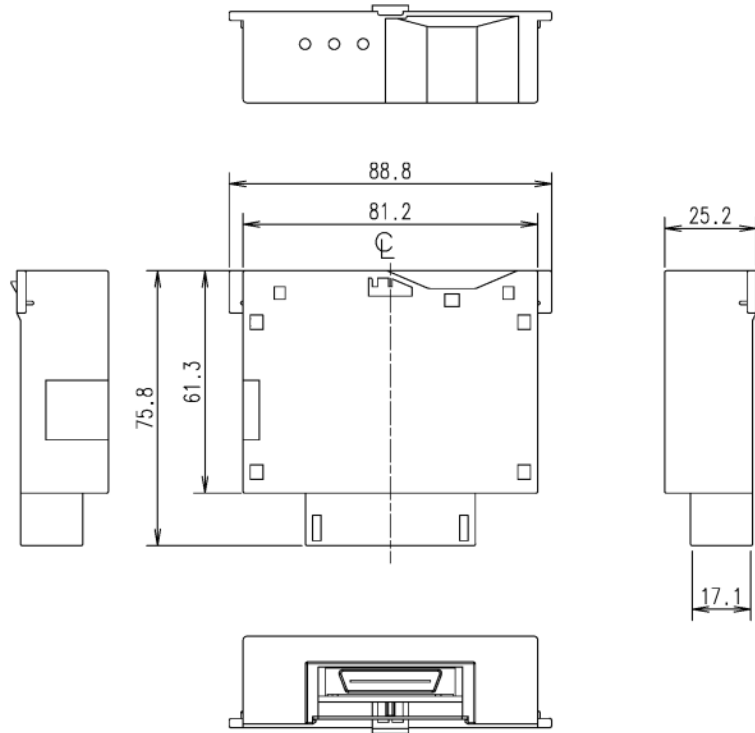

**Optional Plug-in Module**  
**ME-0000BU-SS96**

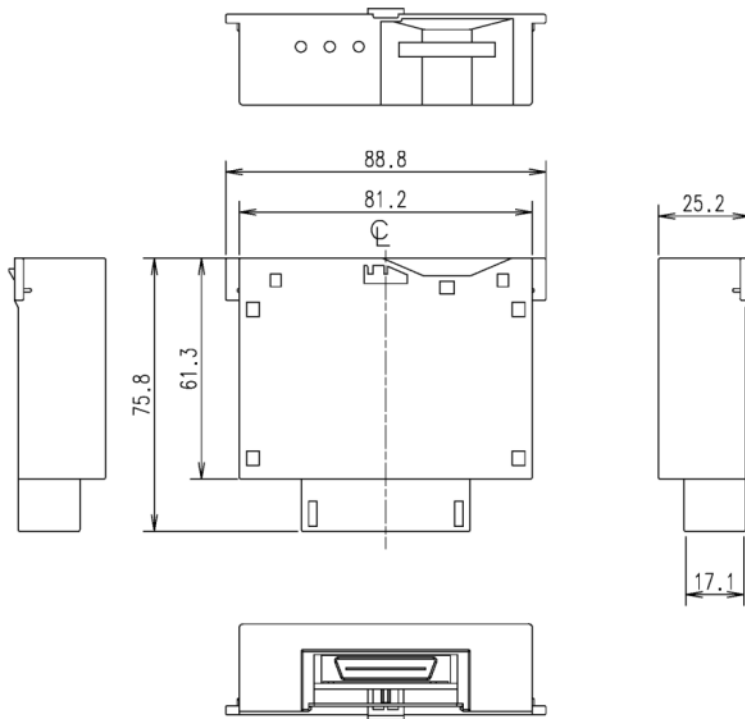

## Installation 2. Mounting

### 1 Dimensions of mounting holes

The drilling dimensions of the panel are as shown in the right figure. The product can be installed to a panel having a thickness of 1.6 to 4.0 mm.

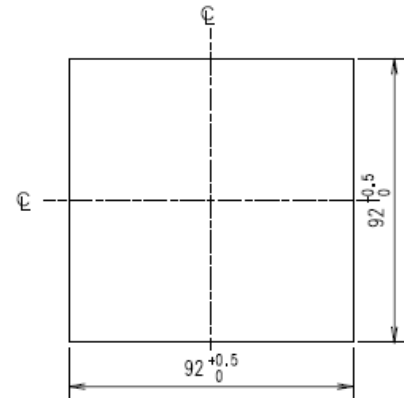

### 2 Mounting position

The contrast of the LCD changes depending on the angle at which it is viewed.

Mount the product in the easy viewable position.

Viewing angle

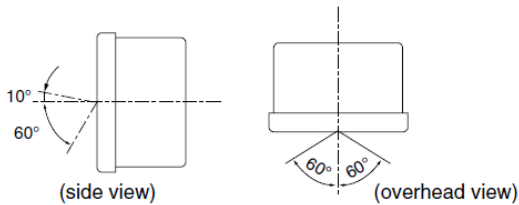

### 3 Mounting and fixing

Mount the product to the panel of the main unit according to the following procedure.

① Attach the mounting brackets to two areas each in upper and lower parts of the main unit.

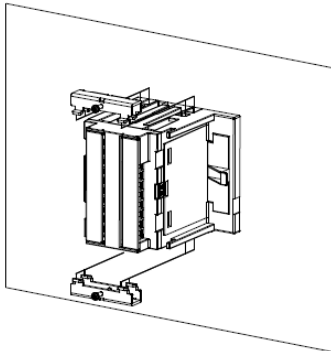

② Tighten the screws of the mounting brackets to fix them to the panel.

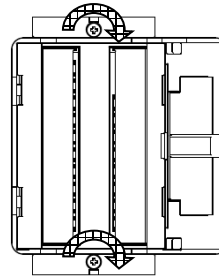

<b>Note</b>	To avoid damage to the panel and screws, do not overtighten the screws. The recommended torque for this product is 0.3 N•m to 0.5 N•m (about half the normal torque). Tighten the upper and lower screws evenly.
-------------	--

Screw type for mounting to the main unit: M3

### 4 Mounting the optional plug-in module

Mount the optional plug-in module to the main unit according to the following procedure.

① Remove the optional cover.

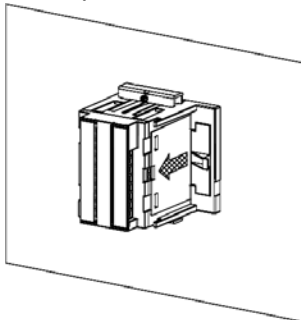

② Mount the optional plug-in module to the main unit.

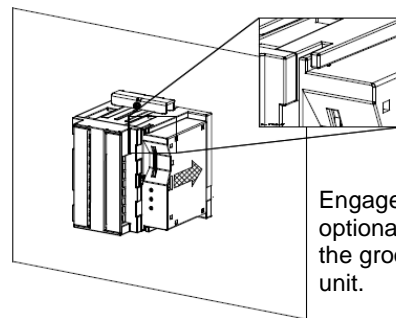

Engage the convex of the optional plug-in module in the groove of the main unit.

#### Note

##### Protecting sheet

The LCD part is covered with a protecting sheet to avoid scratches to the LCD during mounting of the panel. Before starting operation, remove the sheet. When removing the sheet, the LCD may illuminate due to static electricity, but this is not a product failure. After a while, the LCD goes off as it naturally discharges electricity.

##### Mounting position

To mount the product to the edge of the panel, check the space for wiring work before determining the mounting position.

##### Optional plug-in module

Turn off the auxiliary power before mounting the optional plug-in module.

If the optional plug-in module is mounted during energization, the optional plug-in module cannot be recognized on the main unit side.

In this case, turning on/restoring the auxiliary power or performing operation of "restarting the instrument" allows the optional plug-in module to be recognized.

## Installation 3. Wiring

### 1 Applicable electric wire specifications

The following table shows applicable electric wire sizes.

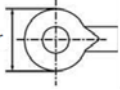
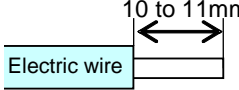
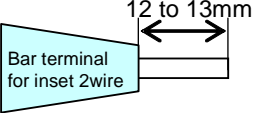
Section	Screw type	Specification of wire used	Tightening torques
Terminal of main unit. (Auxiliary power, Voltage input, Current input, MODBUS <sup>®</sup> RTU communication terminal)	M3	<ul style="list-style-type: none"> <li>Use crimping terminals: AWG26 to 14 (Connectable 2 wires)</li> </ul> <p>Applicable crimping terminals:</p> <p>Outer Diameter  For M3 screw with an outer diameter of less than 6.0mm.</p>	0.6 to 0.8N·m
Terminal of Optional plug-in module ·ME-4210-SS96 ·ME-0040C-SS96 ·ME-0052-SS96	Without screw	<p>Single wire, Stranded wire: AWG24 to 14 Wire coating stripping length : 10 to 11mm (Stranded wire is bar terminal can be used in combination.)</p> <p>Note: UL recognized corresponds, use according to the following conditions.</p> <ul style="list-style-type: none"> <li>Single wire, Stranded wire: AWG24 to 18</li> <li>Bar terminal can be not used in combination.</li> </ul> <p>Note: When using the bar terminal for insert 2 wire, please select insertion length of 12 to 13mm.</p> <p> </p>	-

### 2 Wiring of the main unit.

Be sure to securely tighten the terminal screws to the terminal block.

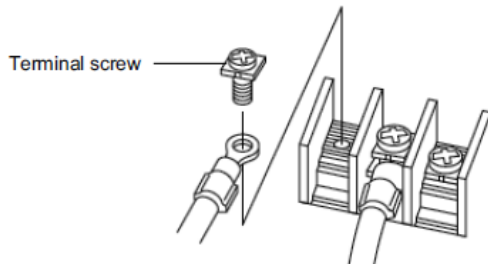

### CAUTION

- Please do not connect three or more electric wires to one terminal. This can cause heat and fire due to imperfect contact.
- If you are using bare crimped terminals, provide the insulation needed to cover exposed live parts and prevent electric shock and short circuits (e.g., use insulated tubing).

### 3 Connection method of terminal of optional plug-in module.

- ① Peel the cover of the electric wire tip or crimp the bar terminal.
- ② With the lever pressed, insert the electric wire and then release the lever for connection.

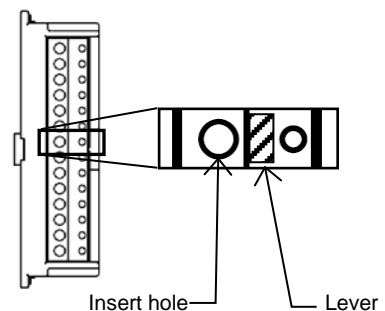

### 4 Checking

Check the following after connection.

- The electric wire is securely connected.
- There is no error in connection.

**⚠ CAUTION**

**Do not work with live wires**

Do not connect terminal and RJ-45 connector with live wires.  
Do not insert and remove SD CRAD with live wires.  
It may cause electric shock, burns, device burn out, or fire.  
It is recommended that a protection fuse be used for VT and the auxiliary power source.

**Do not open the secondary side of the CT circuit**

Connect the CT secondary side signal correctly to the terminal for CT connection.  
If the CT is not connected properly or if the secondary side of the CT is open, it may result in high voltage on the secondary side of the CT, the insulation of the secondary winding wire may be damaged, and burnout may be caused.

**Do not short the secondary side of the VT circuit**

Connect the VT secondary side signal correctly to the terminal for VT connection.  
If the VT is not connected properly or if the secondary side of the VT shorts, over current may flow to the secondary side of the VT, which can burn out the secondary winding wire. If the secondary winding wire burns out, it can damage the insulation of the primary winding wire, resulting in a short between phases.

**Make sure connections to the connection terminals are tight**

Electrical wires must be properly tightened to the connection terminal.  
Otherwise, heat and measurement errors may be caused.

**Do not forget wiring of "C<sub>1</sub>", "C<sub>2</sub>" and "C<sub>3</sub>" for pass.**

When the L side of CT circuit is common wire, it is necessary to short-circuit "C<sub>1</sub>", "C<sub>2</sub>", and "C<sub>3</sub>" terminal of this device.

**Do not use improper electrical wires**

Make sure that the electrical wires have the proper rating for current and voltage.  
If inappropriate electrical wires are used, fire may be caused.

**Do not pull the connection wires with force**

If the terminal wiring is pulled with a strong force, the input and output portion may detach.  
(Tensile load: 39.2N or less)

**Do not apply an abnormal voltage.**

If a pressure test is given to a high-pressure device, a ground must be used in order to avoid damaging this measurement instrument. If a high voltage of AC2000V is applied for over one minute to the measurement instrument, damage may occur.

**Do not connect to Non-Connection (NC) terminal.**

Do not connect to Non-Connection (NC) terminals for the purpose of relay etc.

**Use the proper voltage for the auxiliary power source.**

Use the proper voltage for the auxiliary power source terminal.  
If an improper voltage is used, the instrument may be damaged or fire may be caused.

## Installation 4. Wiring Diagram

Rating voltage for every phase wire system

Phase wire type	Type	Rating voltage	Figure
3-phase 4-wire type	STAR	max AC277V(L-N)/480V(L-L)	Figure 1
3-phase 3-wire type	DELTA	max AC220V(L-L)	Figure 2
	STAR	max AC440V(L-L)	Figure 3
1-phase 3-wire type	—	max AC220V(L-N)/440V(L-L)	Figure 4
1-phase 2-wire type (Note)	DELTA	max AC220V(L-L)	Figure 5
	STAR	max AC440V(L-L)	Figure 6

Note. In case of a circuit which is wired from the delta connection of a 3-phase 3-wire type or a circuit of a transformer of a 1-phase 2-wire type, the maximum rating is "AC220V".  
In case of a circuit which is wired from a 3-phase 4-wire type, the star connection of a 3-phase 3-wire type or a 1-phase 3-wire type, the maximum rating is "AC440V".

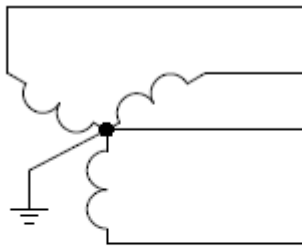

Figure1. 3-PHASE 4-WIRE(STAR)

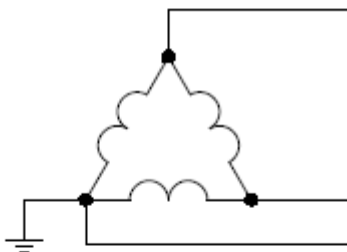

Figure2. 3-PHASE 3-WIRE(DELTA)

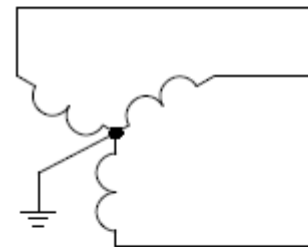

Figure3. 3-PHASE 3-WIRE(STAR)

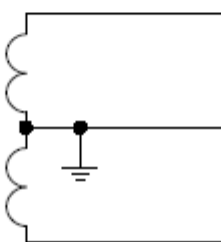

Figure4. 1-PHASE 3-WIRE

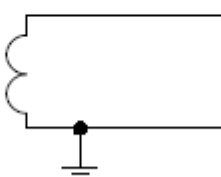

Figure5. 1-PHASE 2-WIRE(DELTA)



Figure6. 1-PHASE 2-WIRE(STAR)

# Installation 4. Wiring Diagram

## 3-phase 4-wire type: Direct input

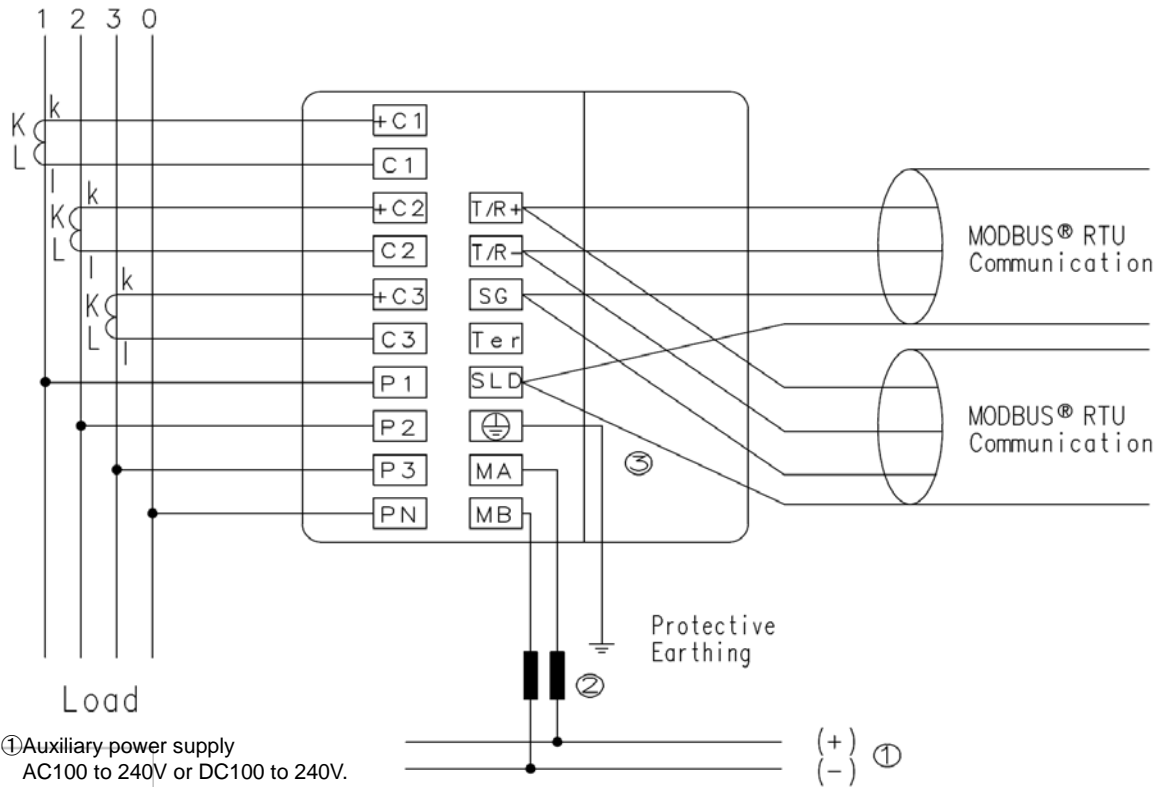

- ①Auxiliary power supply  
AC100 to 240V or DC100 to 240V.
- ②Fuses 0.5A

③Some MODBUS®RTU equipment doesn't have SG. In this case, the wiring between SG is unnecessary.

Note 1: For low voltage circuits, grounding the secondary side of VT and CT is not t necessary.

## 3-phase 4-wire type: With VT

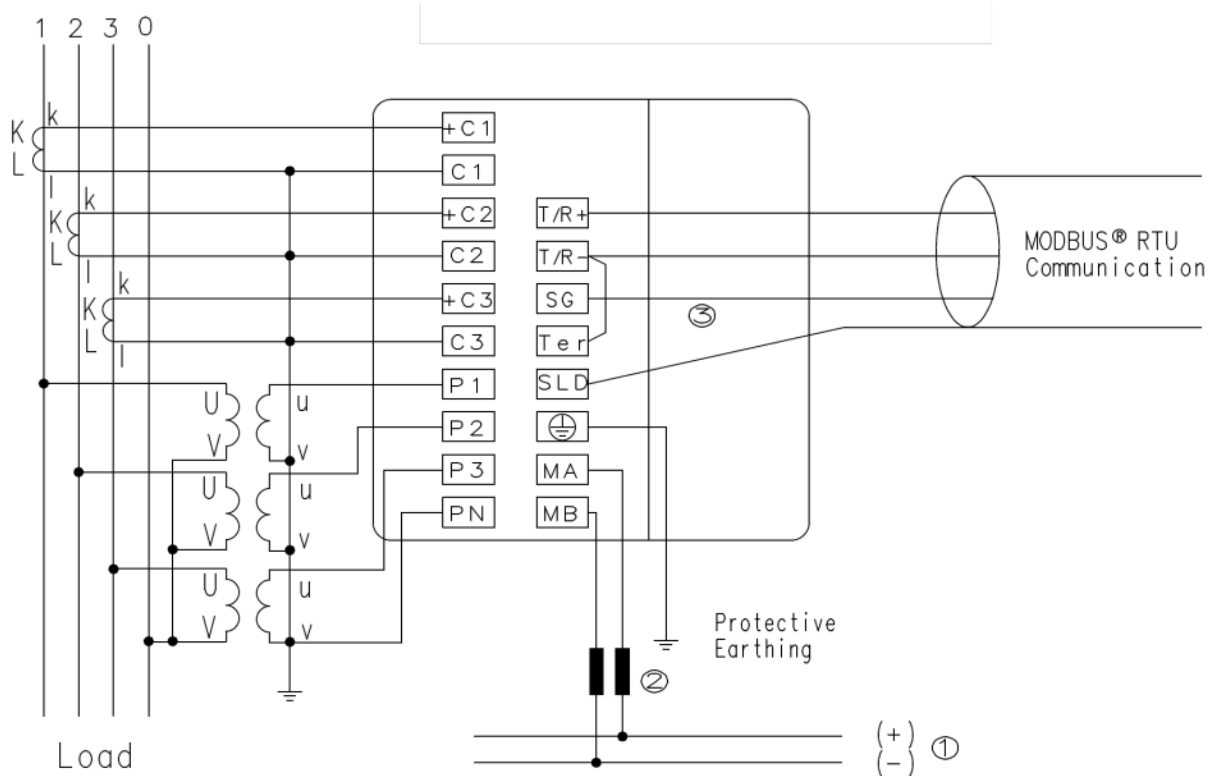

- ①Auxiliary power supply  
AC100 to 240V or DC100 to 240V.
- ②Fuses 0.5A

③Some MODBUS®RTU equipment doesn't have SG. In this case, the wiring between SG is unnecessary.

Note 1: For low voltage circuits, grounding the secondary side of VT and CT is not t necessary.

# Installation 4. Wiring Diagram

## 3-phase 3-wire(2CT) type: Direct input

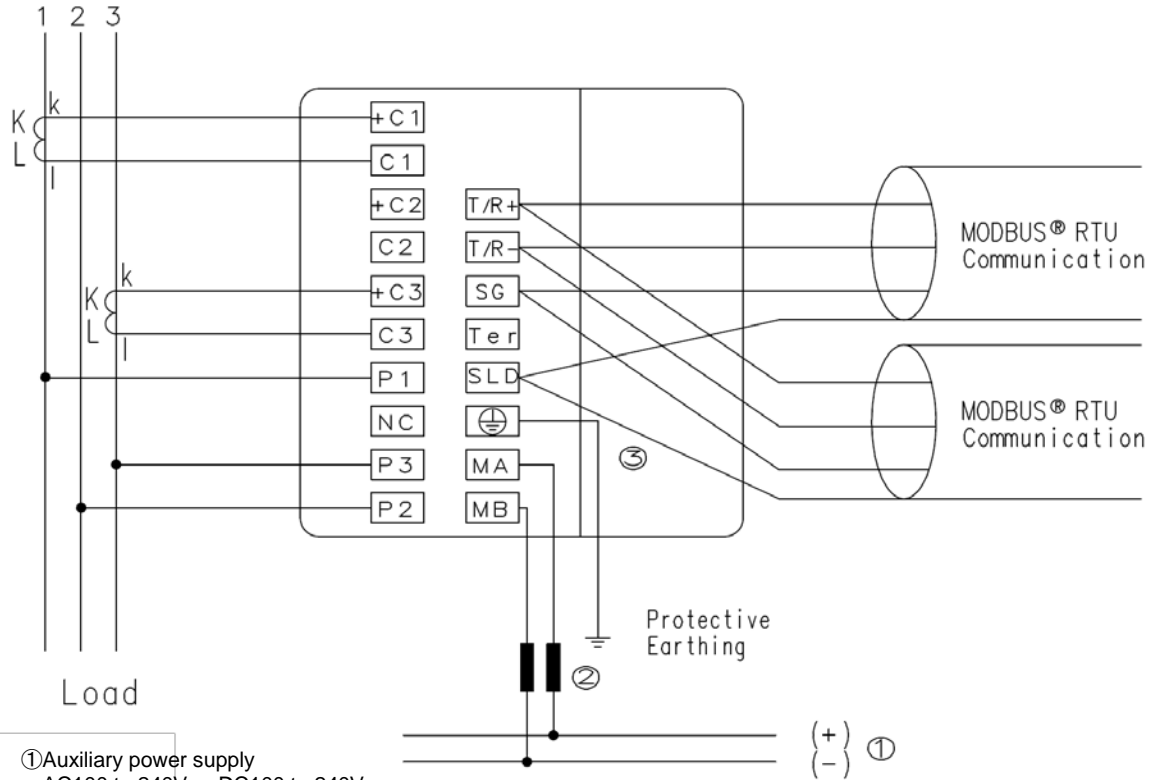

①Auxiliary power supply  
AC100 to 240V or DC100 to 240V.

②Fuses 0.5A

③Some MODBUS®RTU equipment doesn't have SG. In this case, the wiring between SG is unnecessary.

Note 1: For low voltage circuits, grounding the secondary side of VT and CT is not necessary.

Note 2: Do not connect to NC terminal.

## 3-phase 3-wire(3CT) type: With VT

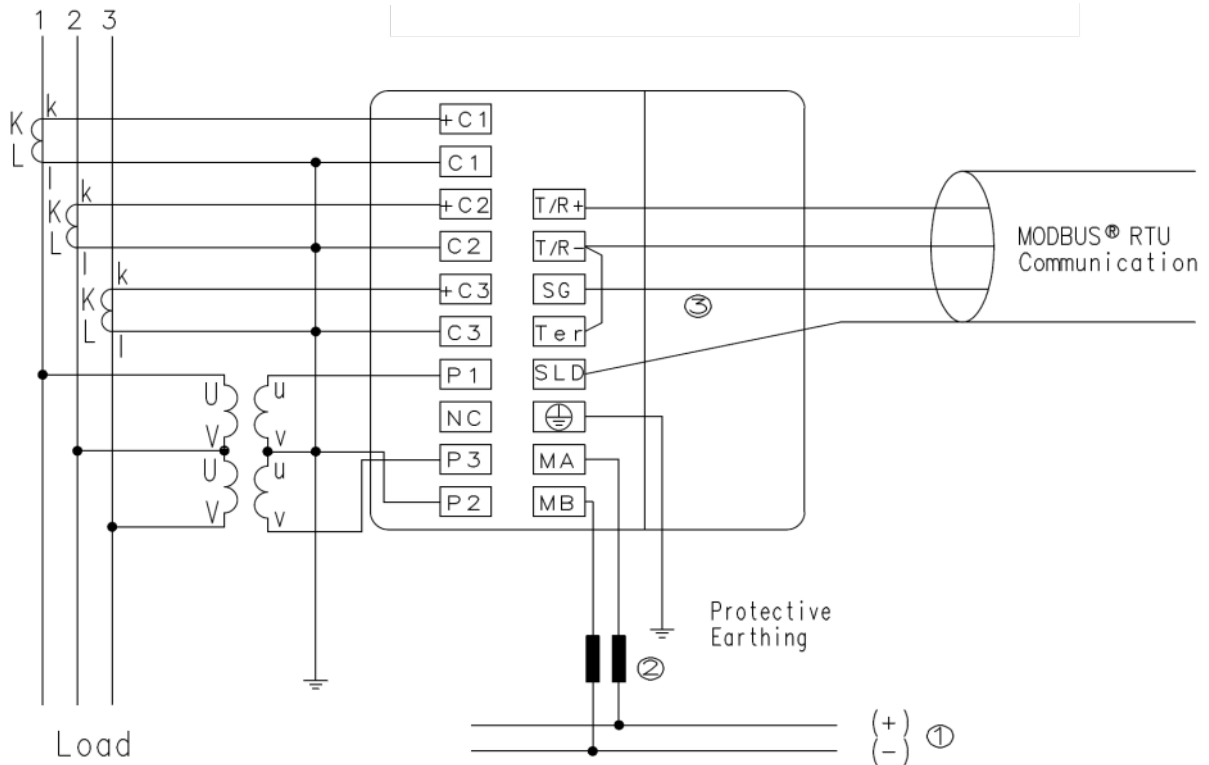

①Auxiliary power supply  
AC100 to 240V or DC100 to 240V.

②Fuses 0.5A

③Some MODBUS®RTU equipment doesn't have SG. In this case, the wiring between SG is unnecessary.

Note 1: For low voltage circuits, grounding the secondary side of VT and CT is not necessary.

Note 2: Do not connect to NC terminal.

## Installation 4. Wiring Diagram

### 1-phase 3-wire type

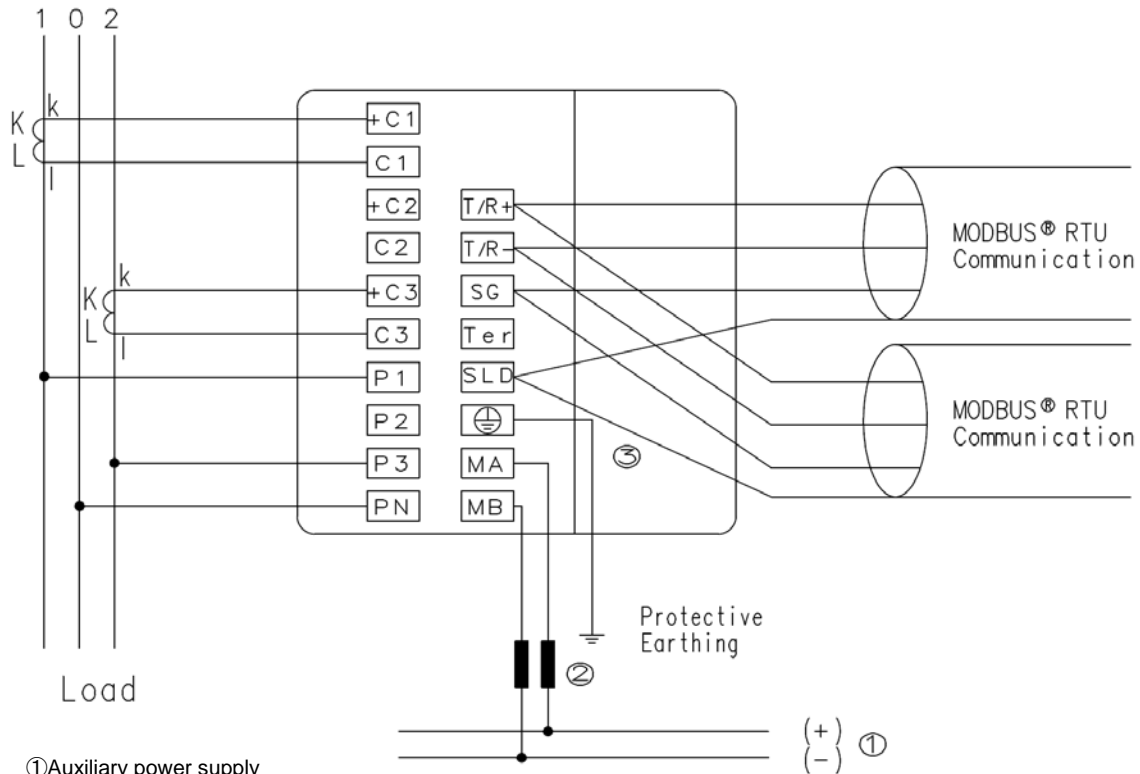

①Auxiliary power supply  
AC100 to 240V or DC100 to 240V.

②Fuses 0.5A

③Some MODBUS®RTU equipment doesn't have SG. In this case, the wiring between SG is unnecessary.

Note 1: For low voltage circuits, grounding the secondary side of CT is not t necessary.

### 1-phase 2-wire type: With VT

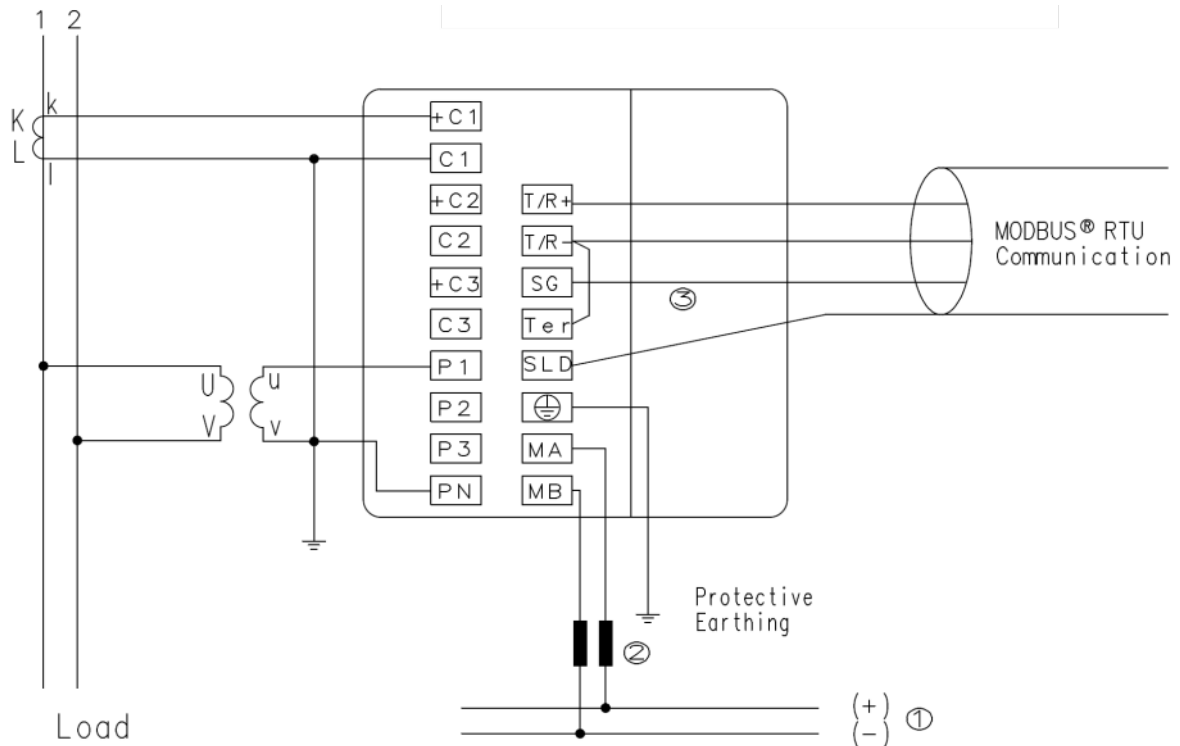

①Auxiliary power supply  
AC100 to 240V or DC100 to 240V.

②Fuses 0.5A

③Some MODBUS®RTU equipment doesn't have SG. In this case, the wiring between SG is unnecessary.

Note 1: For low voltage circuits, grounding the secondary side of VT and CT is not t necessary.



# Installation 4. Wiring Diagram

## Optional Plug-in Module: ME-4210-SS96

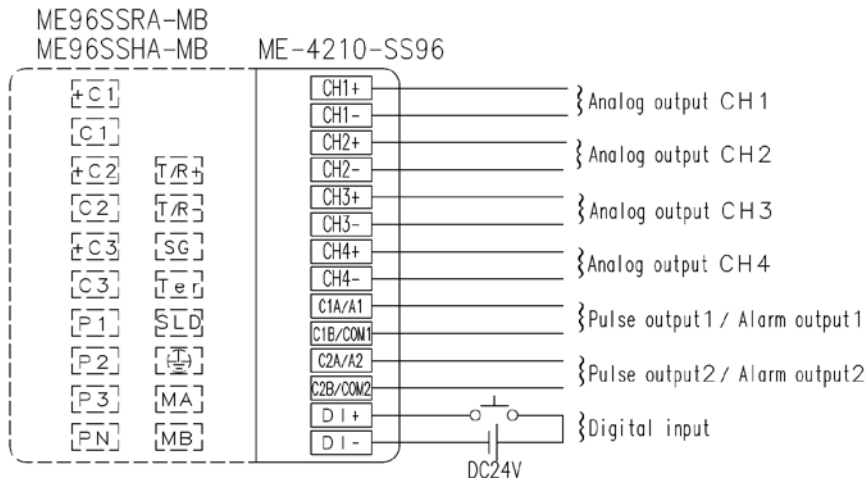

## Optional Plug-in Module: ME-0040C-SS96

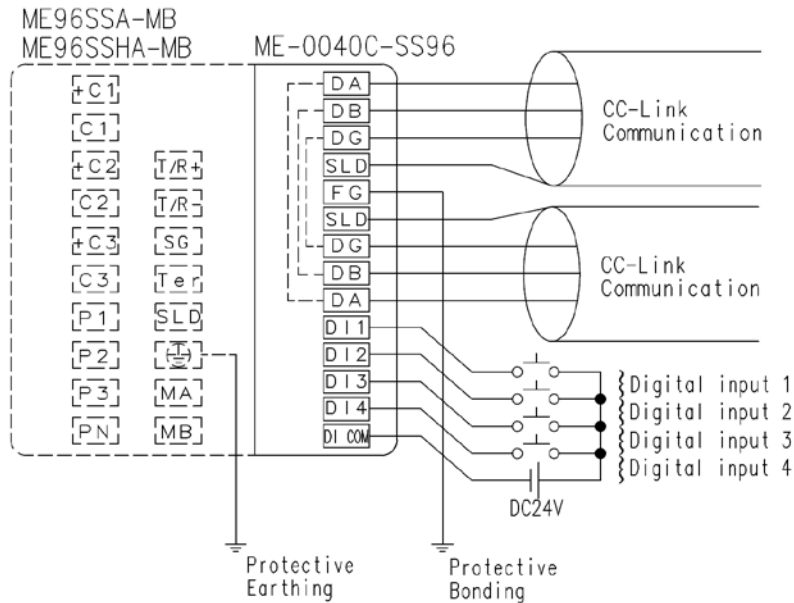

## Optional Plug-in Module: ME-0052-SS96

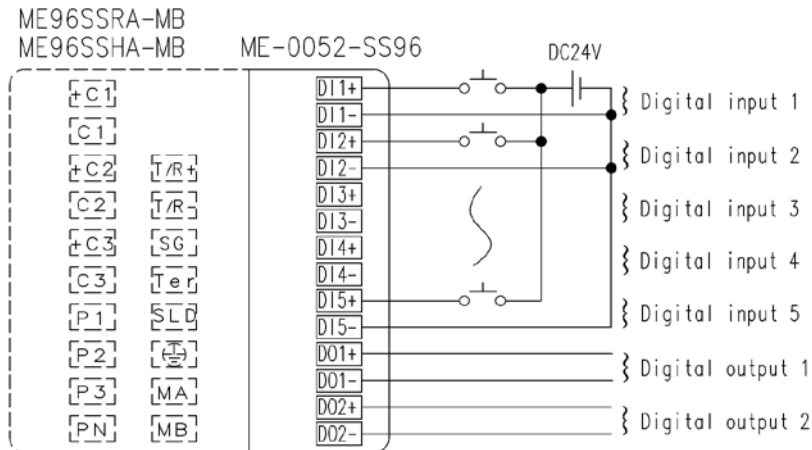

DI1-, DI2-, DI3-, DI4-, DI5-,  
are connected inside.

# Installation 4. Wiring Diagram

## Optional Plug-in Module: ME-0000MT-SS96

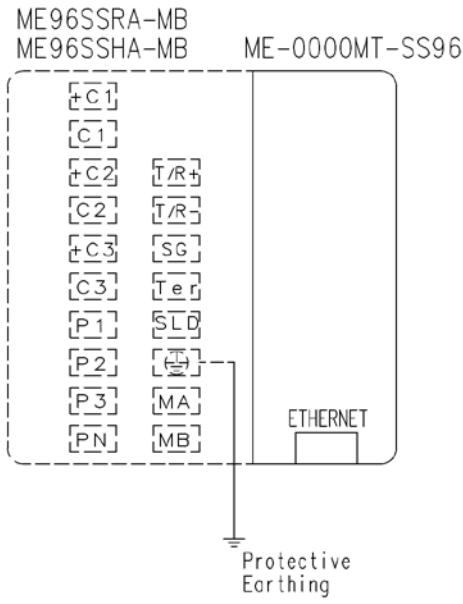

## Optional Plug-in Module: ME-0000BU-SS96

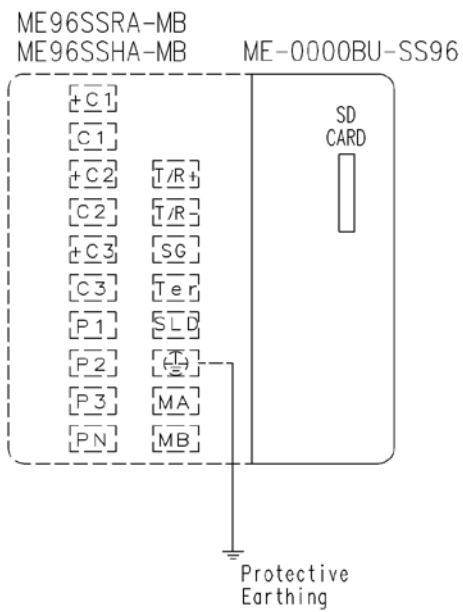

## Installation 4. Wiring Diagram

### Note for Input

<b>Note</b>	<ol style="list-style-type: none"> <li>1. The voltage input terminals for 3-phase 3-wire are different from those for others.</li> <li>2. If the polarity for VT and CT are wrong, the measurement cannot be executed correctly.</li> <li>3. Do not connect wires to the NC terminals.</li> <li>4. In the case of low voltage, there is no need for grounding of the secondary sides of VT and CT.</li> <li>5. Always earth the ⊕ terminal to the protective earth conductor. Earth the terminal with less than 100 ohm of earth resistance. Otherwise there will be a false operation.</li> </ol>
-------------	--

### Note for Output

<b>Note</b>	<ol style="list-style-type: none"> <li>1. Do not bunch pulse outputs, alarm outputs and digital inputs/outputs signal cables with the main circuit or power cables, or install them close to each other. Keep the distance between the inputs/outputs signal cables and the main circuit or power cables and high voltage lines shown below, when they run parallel to each other. <table border="1" style="margin: 10px auto;"> <thead> <tr> <th style="text-align: center;">Conditions</th> <th style="text-align: center;">Distance</th> </tr> </thead> <tbody> <tr> <td style="text-align: center;">Below 600V and less than 600A power lines</td> <td style="text-align: center;">30cm or more</td> </tr> <tr> <td style="text-align: center;">Other power lines</td> <td style="text-align: center;">60cm or more</td> </tr> </tbody> </table> </li> <li>2. Analog outputs signal cables should keep the distance from the other power cables and input signal (VT, CT and auxiliary power) cables, and should not be bunched. And use the shielded cables or twisted pair cables so that it is not affected the noise, serge, and induction. Also, the wiring cables should be as short as possible.</li> <li>3. MODBUS<sup>®</sup>RTU interface and analog outputs of ME-4210-SS96 do not have the insulation between them.</li> </ol>	Conditions	Distance	Below 600V and less than 600A power lines	30cm or more	Other power lines	60cm or more
Conditions	Distance						
Below 600V and less than 600A power lines	30cm or more						
Other power lines	60cm or more						

### Note for MODBUS<sup>®</sup>RTU

<b>Note</b>	<ol style="list-style-type: none"> <li>1. Use the shielded twisted pair cable. (Recommended cables: Refer to page 102.)</li> <li>2. To the units at both ends of the MODBUS<sup>®</sup>RTU link, the 120-ohm resistance has to be attached. This instrument can perform a 120-ohm termination by short-circuiting the terminal of T/R- and Ter.</li> <li>3. The earthing has to be connected to earth by a thick wire of low impedance.</li> <li>4. Keep the distance between MODBUS<sup>®</sup>RTU link to power lines.</li> <li>5. Connect to earth the SLD terminal at one end.</li> </ol>
-------------	---

### Note for CC-Link

<b>Note</b>	<ol style="list-style-type: none"> <li>1. As for CC-link cable, use the designated cable. (Refer to page 102.) Ver.1.10-compatible CC-Link dedicated cables, CC-Link dedicated cables (Ver.1.00) and CC-Link dedicated high-performance cables cannot be used together. If used together, correct data transmission will not be guaranteed. Also attach the terminating resistor which matches the kind of the cable.</li> <li>2. Connect the shielded wire of the CC-Link dedicated cable to "SLD" of each module, and ground both ends of the shielded wire using grounding via "FG". The SLD and FG are connected within the module.</li> <li>3. Because the CC-Link transmission line is a small signal circuit, it should be separated from any strong-current circuit by 10cm or more. However, if it is laid parallel for a long distance, it must be laid at least 30cm away. The terminal must be grounded before using.</li> <li>4. The CC-Link transmission line should use an exclusive line that meets the requirements for total wiring length, distance between stations, and termination resistance values according to the communication speed. If you do not use an exclusive line or observe the wiring requirements, communication may fail. (Refer to the "CC-Link Cable Wiring Manual" about the exclusive line and wiring requirements.)</li> <li>5. Connect the supplied "terminal resistor" to each module at both ends of the CC-Link system. Connect the terminal resistors between "DA" and "DB".</li> <li>6. CC-Link interface and MODBUS<sup>®</sup>RTU do not have the insulation between them.</li> </ol>
-------------	---

## Installation 4. Wiring Diagram

### Note for MODBUS@TCP

<b>Note</b>	<p>1. In 100Mbps communication by the 100BASE-TX connection, a communication error may occur under the influence of high frequency noise from devices other than this device in the installation environment. Take the following action to prevent the influence of high frequency noise in the construction of a network system.</p> <p>(1) Wiring connection</p> <ul style="list-style-type: none"><li>• Do not install a twisted pair cable together with the main circuit and power cables, etc.</li><li>• Place the twisted pair cable in a duct.</li></ul> <p>(2) Communication system</p> <ul style="list-style-type: none"><li>• Increase the number of communication retries if necessary.</li><li>• Change the hub used for connection into a 10Mbps hub, and make communication at a transmission speed of 10Mbps.</li></ul>
-------------	---

## Installation 5. How to insert and eject the SD memory card (ME-0000BU-SS96)

### ■ How to insert the SD memory card

Slide the SD memory card straight into the slot until it clicks into place.

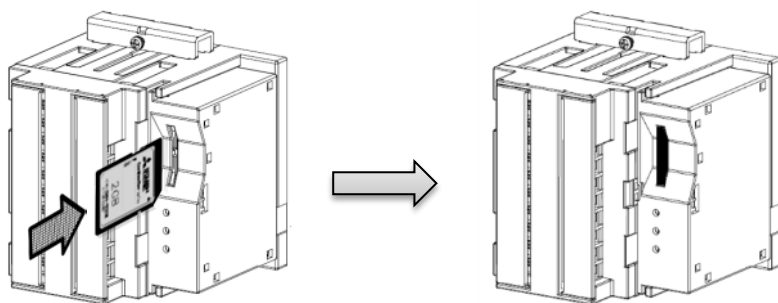

<b>CAUTION</b>	<ul style="list-style-type: none"><li>• Make sure to use the SD memory card manufactured by Mitsubishi Electric Corporation (Model EMU4-SD2GB). Using the other types of the SD memory card may cause the trouble such as data destruction of the memory card or system failure.</li><li>• Insert the SD memory card with the write protect switch “OFF”. If the write protect switch is “ON”, the ME-0000BU-SS96 does not communicate with an SD memory card.</li></ul>
----------------	--

### ■ How to eject the SD memory card

- 1) Check the SD C. LED turns off
- 2) Push the SD memory card in until it clicks into place.
- 3) The SD memory card comes out by itself.

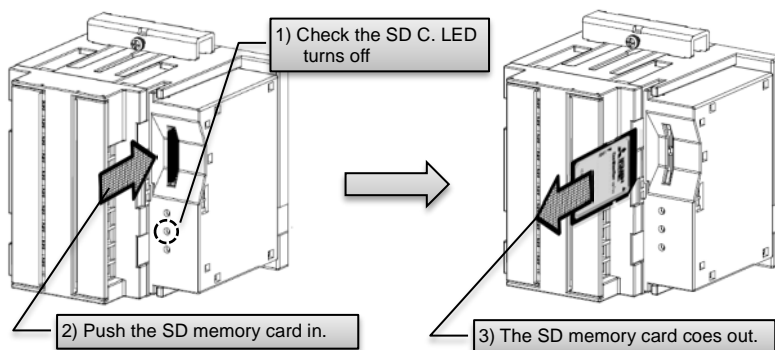

<b>CAUTION</b>	<p>During communication with the SD memory card, ejection of the memory card may cause data corruption of the memory card or failure of this unit or the memory card. Check that SD C.LED turns off to eject the SD memory card.</p>
----------------	--

# Specifications

## 1. Specification

Type		ME96SSRA-MB
Phase wire system		3-PHASE 4-WIRE, 3-PHASE 3-WIRE(3CT, 2CT), 1-PHASE 3-WIRE, 1-PHASE 2-WIRE (common)
Rating	Current	AC5A, AC1A (common)
	Voltage	3-PHASE 4-WIRE : max AC277/480V 3-PHASE 3-WIRE : (DELTA)max AC220V, (STAR)max AC440V 1-PHASE 3-WIRE : max AC220/440V 1-PHASE 2-WIRE : (DELTA)max AC220V, (STAR)max AC440V
	Frequency	50-60Hz (common)
Item	Measurement Item	Accuracy
Current (A)	A1, A2, A3, AN, A <sub>AVG</sub>	±0.2%
Current Demand (DA)	DA1, DA2, DA3, DAN, DA <sub>AVG</sub>	
Voltage (V)	V12, V23, V31, V <sub>AVG</sub> (L-L), V1N, V2N, V3N, V <sub>AVG</sub> (L-N)	
Active Power (W)	W1, W2, W3, ΣW	±0.5%
Reactive Power (var)	var1, var2, var3, Σvar	
Apparent Power (VA)	VA1, VA2, VA3, ΣVA	
Power Factor (PF)	PF1, PF2, PF3, ΣPF	
Frequency (Hz)	Hz	±0.1%
Active Energy (Wh)	Imported, Exported	class0.5S (IEC62053-22)
Reactive Energy (varh)	Imported Lag, Imported Lead, Exported Lag, Exported Lead	class1S (IEC62053-24)
Apparent Energy (VAh)	Imported + Exported	±2.0%
Harmonic current (HI)	Total, 1 to 19th(Only odd number)	±1.0%
Harmonic voltage (HV)	Total, 1 to 19th(Only odd number)	
Rolling Demand(DW)	Rolling Block, Fixing Block (Selectable by setting)	±0.5%
Rolling Demand(Dvar)	Rolling Block, Fixing Block (Selectable by setting)	±1.0%
Rolling Demand(DVA)	Rolling Block, Fixing Block (Selectable by setting)	
Periodic Active Energy (Wh)	Periodic Active Energy 1, Periodic Active Energy 2	class0.5S (IEC62053-22)
Operation time (h)	Operation time 1, Operation time 2	(Reference)
Analog output response time		2 s or less (HI and HV: 10s or less)
Measuring Method	Instantaneous Value	A·V: RMS calculation, W·var·VA·Wh·varh·VAh: Digital multiplication, PF: Power ratio calculation, Hz: Zero-cross, HI·HV: FFT
	Demand Value	DA: Thermal type calculation, DW: Rolling Demand calculation
Display	Type	LCD with backlight
	Maximum Number of Display Digits or Segment Number	Upper stage display: 6 digits, Middle stage display: 6 digits, Lower stage display: 6 digits A, DA, V, W, var, VA, PF DW, Dvar, DVA: 4 digits Hz: 3 digits Wh, varh, VAh: 9 digits(6 digits or 12 digits possible) Harmonic total distortion ratio: 3 digits Harmonic RMS value: 4 digits Operation time: 6 digits Digital input/output: I/O
	Bar graph	21 Segment-Bar graph, 22 Segment-Indicator
	Display updating time interval	0.5s, 1s
Communication Specification		MODBUS <sup>®</sup> RTU communication
Accessible option unit		ME-4210-SS96, ME-0040C-SS96, ME-0052-SS96, ME-0000MT-SS96, ME-0000BU-SS96
Analog output	Output specification	DC4 to 20mA(0 to 600Ω)
Pulse/Alarm output	The kind of switch	No-voltage 'a' contact
	Contact Capacity	DC35V, 0.1A
	Pulse width	0.125s, 0.5s, 1.0s
Digital input(DI)	Contact Capacity	DC24V(DC19 to 30V), 7mA or less
	Signal width	30ms or longer
Digital output(DO)	The kind of switch	No-voltage 'a' contact
	Contact Capacity	DC35V, 0.2A
Power Failure Compensation		Non volatile memory(Items : Setting value, MAX/MIN value, Active/Reactive/Apparent energy, Periodic Active Energy, Rolling Demand, Operation time)
VA Consumption	VT	0.1VA/phase (at 110VAC), 0.2VA/phase(at 220VAC) , 0.4VA/phase(at 440VAC)
	CT	0.1VA/phase (at 5AAC)
	Auxiliary power	7VA(AC110V), 8VA(AC220V), 5W(DC100V)
Auxiliary power		AC100-240V(±15%), DC100-240V(-30% +15%)
Weight		0.5kg
Dimension		96(H)×96(W)×90(D)
Attachment Method		Embedding attachment
Operating temperature/humidity		-5 to +55°C(average temperature : 35°C or less per day), 0 to 85%RH, non condensing
Storage temperature/ humidity		-25 to +75°C(average temperature : 35°C or less per day), 0 to 85%RH, non condensing

Note1: Accuracy is specified according to the maximum scales value of rated value.

Note2: Measurement of harmonics which its distortion ratio is exceeded 100% may exceed the accuracy.

Note3: Harmonics cannot be measured without voltage input.

# Specifications

## 2. Applicable Standards

Electromagnetic Compatibility	
Emissions	
Radiated Emission	EN61326-1/CISPR 11, FCC Part15 Subpart B Class A
Conducted Emission	EN61326-1/CISPR 11, FCC Part15 Subpart B Class A
Harmonics Measurement	EN61000-3-2
Flicker Meter Measurement	EN61000-3-3
Immunity	
Electrostatic discharge Immunity	EN61326-1/EN61000-4-2
Radio Frequency Electromagnetic field Immunity	EN61326-1/EN61000-4-3
Electrical Fast Transient/Burst Immunity	EN61326-1/EN61000-4-4
Surge Immunity	EN61326-1/EN61000-4-5
Conducted Disturbances, Induced By Radio Frequency Fields Immunity	EN61326-1/EN61000-4-6
Power Frequency Magnetic Field Immunity	EN61326-1/EN61000-4-8
Voltage Dips and Short Interruptions	EN61326-1/EN61000-4-11

Safety	
Europe	CE, as per EN61010-1
U.S. and Canada	cRUus as per UL61010-1, IEC61010-1
Installation Category	III
Measuring Category	III
Pollution Degree	2

## 3. Specifications of MODBUS® RTU Communication

Item	Specifications
Physical interface	RS – 485 2wires half duplex
Protocol	RTU (Binary data)
Synchronization method	Start-stop synchronization
Network topology	Daisy-chain
Baud rate	2400, 4800, 9600, 19200, 38400bps
Data bit	8
Stop bit	1, 2
Parity	Odd, Even, None
Slave address	1 to 255 (0 : For broadcast)
Distance	1200m
Maximum Number	31
Response time	1s or less (time to a response after receiving a query)
Terminate	120Ω 1/2W
Recommended cable	Shielded twisted pair, AWG24 to 14 gauge

■ About Programming

In addition to this manual, read the following documents too.

- Electronic Multi-Measuring Instrument ME Series MODBUS® Interface specifications ..... LSPM-0075

## 4. Specifications of CC-Link Communication

Item	Specifications
CC-Link station type	Remote device station (ver.1 remote device station or ver.2 remote device station)
Number of occupied stations	Ver.1 remote device station (ver.1 compatible slave station) setting: 1 station Ver.2 remote device station (ver.2 compatible slave station) setting: 1 station (Expanded cyclic setting: Octuple)
CC-Link version	CC-Link Ver 1.10 / 2.00
Transmission speed	Can select from 156kbps / 625kbps / 2.5Mbps / 5Mbps / 10Mbps
Maximum number of connected stations	If the system is configured by only this instrument, up to 42 units can be connected. (note1)

■ CC-Link Dedicated Cable

Use the CC-Link dedicated cables for the CC-Link system. If a cable other than the CC-Link dedicated cable is used, the performance of the CC-Link system cannot be guaranteed.

For the specifications of the CC-Link dedicated cables or any other inquiries, visit the following website:

CC-Link Partner Association: <http://www.CC-link.org/>

REMARK

For details, refer to the CC-Link cable wiring manual issued by CC-Link Partner Association.

■ About Programming

In addition to this manual, read the following documents too.

- Electronic Multi-Measuring Instrument programming manual (CC-Link) ..... LEN080334
- Electronic Multi-Measuring Instrument programming manual (CC-Link)(For ver. 2 remote device station)..... LEN130391

Note1: As for details, refer to the above manuals.

## Specifications

### 5. Specifications of MODBUS<sup>®</sup> TCP Communication

Item		Specifications
Interface		1 port (10BASE-T/100BASE-TX)
Transmission method		Base band
Number of cascade connection stages *1		Max. 4 stages (10BASE-T), Max. 2 stages (100BASE-TX)
Maximum node-to-node distance		200m (656.16ft.)
Maximum segment length *2		100m (328.08ft.)
Connector applicable for external wiring		RJ45
Cable	10BASE-T	Cable compliant with the IEEE802.3 10BASE-T Standard (unshielded twisted pair cable (UTP cable), Category 3 or more)
	100BASE-TX	Cable compliant with the IEEE802.3 100BASE-TX Standard (shielded twisted pair cable (STP cable), Category 5 or more)
Protocol		MODBUS TCP (Port number 502)
Number of simultaneously connection		Max. 4 connection
Functions supported		Autonegotiation (10BASE-T/100BASE-TX automatically detected) Auto MDIX function (straight/crossover cable automatically detected)

\*1. This is the maximum number of cascade connection stages when a repeater hub is used.

For the maximum number of cascade connection stages, contact to the manufacturer for the switching hub used.

\*2. Length between a hub and a node.

#### ■ About Programming

In addition to this manual, read the following documents too.

- Electronic Multi-Measuring Instrument ME Series MODBUS<sup>®</sup> Interface specifications ..... LSPM-0075

### 6. Specifications of Logging

Item		Specifications	
Logging mode		Auto overwriting updating	
Type of logging data (*1)	Detailed data	Memorize measured data in the specified "Detailed data logging cycle" (1 minute, 5 minutes, 10 minutes, 15 minutes or 30 minutes). Data is output as detailed data file.	
	One-hour data	Memorize measured data in one-hour cycle. Data is output as One-hour data file and One-day data file	
The number of logging items	Detailed data	Up to 6 items	
	One-hour data	Up to 6 items	
Internal memory logging period	Detailed data	Logging cycle	Logging period
		1minute	2 days
		5minute	10 days
		10minute	20 days
		15minute	30 days
30minute	60 days		
	One-hour data	400 days (About 13 months)	
Logging period with SD memory card (2GB) *2		10 years or longer	
System log data		1200 records	
Output format of logging data and system log data		CSV format (ASCII)	
Compensation for power failure		Lithium battery (Embedded in ME-0000BU-SS96) Total time of compensation is 5 year (average daily temperature is less than +35°C). (Lifetime expectancy of lithium battery is 10 year) (average daily temperature is less than +35°C). It is impossible for customer to exchange the battery. Please consider renewal.	
Setting values (Logging ID, Logging items, Detailed data logging cycle)		Memorized in FRAM (nonvolatile memory) The data is memorized during power failure.	
Logging data, System log data		Memorized in SRAM (volatile memory) Data is erased if power failure occurs under low battery voltage condition (BAT.LED turns on).	
Clock time operation		Clock time operation is stopped if power failure occurs under low battery voltage condition (BAT.LED turns on). After power recovery, timing is started from Jan 1, 2016 00:00:00.	
Clock accuracy		Within ±1 minute per month (at 25°C)	
Memory media for data output *3		SD memory card (SD, SDHC)	
Optional part		SD memory card (EMU4-SD2GB) *3 *4	

\*1. Energy data (Wh, varh, VAh) is measuring data in ME96SS. These are not difference value calculated by logging cycle.

\*2. It is the period until capacity of 2GB SD memory card is filled in always-on connection. Data amount depends on the number of characters. It is the logging period when data is output in maximum volume.

\*3. Make sure to use the SD memory card manufactured by Mitsubishi Electric Corporation (Model EMU4-SD2GB). Using the other types of the SD memory card may cause the trouble such as data destruction of the memory card or system failure.

\*4. For purchase of optional parts, contact the shop you bought this product.

In addition to this manual, read the following documents too.

- ME-0000BU-SS96:Logging specifications ..... LSPM-0092



# Specifications

## 7. Setting Table (Factory Settings and Customer Setting Note)

Setting menu No.	Setting items	Initial content	Memo	
1	1.1	Phase wire system	3P4(3-phase 4-wire)	
	1.2	Display pattern	P04	
		1.2.1	Pattern P00	—
	1.3	VT/direct selection	no(No VT)	
		1.3.1	Direct voltage	220/380V
		1.3.2	VT secondary voltage	—
		1.3.3	VT primary voltage	—
	1.4	CT secondary current	5A	
		1.4.1	CT primary current	5A
	1.5	Frequency	50Hz	
1.6	Time constant for rolling demand (Interval time constant)	15min		
	1.6.1	Subinterval time constant	1min	
1.7	Time constant for current demand	0s		
2	2.1	Communication setting selection	CC or Mb.tCP	
	2.2	MODBUS <sup>®</sup> RTU address	1	
		2.2.1	MODBUS <sup>®</sup> RTU baud rate	19.2kbps
		2.2.2	MODBUS <sup>®</sup> RTU parity	EVEn(even)
		2.2.3	MODBUS <sup>®</sup> RTU stop bit	1
	2.3	CC-Link station number	1	
		2.3.1	CC-Link baud rate	156kbps
		2.3.2	CC-Link version	1.10
		2.3.3	Communication reset	oFF
	2.4	MODBUS <sup>®</sup> TCP IP address	192.168.3.10	
		MODBUS <sup>®</sup> TCP Subnet mask	255.255.255.0	
		MODBUS <sup>®</sup> TCP Default gateway existence	oFF(No existence)	
		MODBUS <sup>®</sup> TCP Default gateway	127.0.0.1	
Communication reset		oFF		
3	3.1	Current maximum scale	5A(CT primary current)	
		3.1.1	Special current maximum scale	—
	3.2	Voltage maximum scale	300V(±0 STEP)	
	3.3	Power maximum scale	4000W(±0 STEP)	
		3.3.1	Single / Double deflection	Single deflection
	3.4	Reactive power maximum scale	4000var(±0 STEP)	
	3.5	Power factor scale	0.5(-0.5 to 1 to 0.5)	
	3.6	Expanded counting	Combination I	
3.7	Harmonics display	oFF		
4	4.1	Model name + option code	(Model name)	
	4.2	Version display	(Version)	
	4.3	Back light brightness	3	
	4.4	Back light auto off	Auto(Auto off)	
	4.5	Display update time	0.5s	
5	5.1	Alarm item 1	non	
		5.1.1	Alarm value 1	—
	5.2	Alarm item 2	non	
		5.2.1	Alarm value 2	—
	5.3	Alarm item 3	non	
		5.3.1	Alarm value 3	—
	5.4	Alarm item 4	non	
		5.4.1	Alarm value 4	—
	5.5	Alarm delay time	—	
	5.6	Alarm cancel method	—	
	5.7	Back light flickers during alarms	—	
	5.8	Motor start-up current masking	oFF	
		5.8.1	Motor start-up current threshold	—
			5.8.2	Motor start-up current delay time
5.9		Pulse / Alarm output 1 (With ME-4210-SS96)	PULSE(Pulse output)	
	5.9.1	Pulse output 1: output item	Wh	
	5.9.2	Pulse output 1: pulse unit	0.001kWh/pulse	
5.10	Pulse / Alarm output 2 (With ME-4210-SS96)	AL (Alarm output)		
	5.10.1	Pulse output 2: output item	—	
	5.10.2	Pulse output 2: pulse unit	—	
5.11	Pulse width	0.125s		

## Specifications

### 7. Setting Table (Factory Settings and Customer Setting Note)

Setting menu No.	Setting items	Initial content	Memo
6	6.1	Analog output CH1: output item	$A_{AVG}$
	6.1.1	Detailed setting (1)	5A(CT primary current)
	6.1.2	Detailed setting (2)	—
	6.2	Analog output CH2: output item	$V_{AVG(L-N)}$
	6.2.1	Detailed setting (1)	300V( $\pm 0$ STEP)
	6.2.2	Detailed setting (2)	—
	6.3	Analog output CH3: output item	$\Sigma W$
	6.3.1	Detailed setting (1)	4000W( $\pm 0$ STEP)
	6.3.2	Detailed setting (2)	Single deflection
	6.4	Analog output CH4: output item	$\Sigma PF$
	6.4.1	Detailed setting (1)	0.5(-0.5 to 1 to 0.5)
6.4.2	Detailed setting (2)	—	
6.5	Analog output limit	oFF	
6	6.1	Logging ID	001
	6.2	Logging data clear	no (Not clear)
	6.2.1	Logging data clear reconfirm	no (Not clear)
	6.3	Logging-item pattern	LP01
6.4	Detailed data logging cycle	15min	
7	7.1	Periodic Active energy display	oFF(Not displayed)
	7.1.1	Control setting for switching time segments of periodic active energy	non(Not switched)
	7.2	Rolling demand display	oFF(Not displayed)
	7.2.1	Rolling demand time setting	oFF(Manual)
	7.3	Digital input/output status display	oFF(Not displayed)
7.3.1	Digital input reset method	Auto(Auto off)	
8	8.1	Operating time display	oFF
	8.1.1	Target for counting Operation time setting	AUX(Auxiliary power)
	8.1.2	Operating time threshold	—
	8.2	Switch element information	123
8.3	Set IEC mode	oFF(Normal mode)	

## Appendix

### 1. Calculation methods of ME96SS (for 3 phase unbalanced system with neutral)

Item	Normal mode	IEC mode	Remark
R.m.s current for phase p	$I_p = \sqrt{\frac{\sum_{k=0}^{N-1} i_{p_k}^2}{N}}$		
R.m.s neutral current	$I_N = \sqrt{\frac{\sum_{k=0}^{N-1} (i_{1_k} + i_{2_k} + i_{3_k})^2}{N}}$		
Lp-N r.m.s voltage	$V_{pN} = \sqrt{\frac{\sum_{k=0}^{N-1} v_{pN_k}^2}{N}}$		
Lp-Lg r.m.s voltage	$V_{pg} = \sqrt{\frac{\sum_{k=0}^{N-1} (v_{gN_k} - v_{pN_k})^2}{N}}$		
Active power for phase p	$P_p = \frac{1}{N} \cdot \sum_{k=0}^{N-1} (v_{pN_k} \times i_{p_k})$		
Apparent power for phase p	$S_p = V_{pN} \times I_p$		
Reactive power for phase p	$Q_p = \frac{1}{N} \cdot \sum_{k=0}^{N-1} (v_{pN_k} \times i_{90-p_k})$ where $i_{90-p_k}$ is the current waveform shifted by 90°.	$Q_p = \sqrt{S_p^2 - P_p^2}$	Refer to page 69 for the sign.
Power factor for phase p	$PF_p = \frac{P_p}{\sqrt{P_p^2 + Q_p^2}}$	$PF_p = \frac{P_p}{S_p}$	Refer to page 69 for the sign.
Total active power	$P = P_1 + P_2 + P_3$		
Total reactive power	$Q = Q_1 + Q_2 + Q_3$		Refer to page 69 for the sign.
Total apparent power	$S = S_1 + S_2 + S_3$	$S = \sqrt{P^2 + Q^2}$	
Total power factor	$PF = \frac{P}{\sqrt{P^2 + Q^2}}$	$PF = \frac{P}{S}$	Refer to page 69 for the sign.

## 2. Optional part (Available part)

### ■ SD memory card

Item	Specifications
Model	EMU4-SD2GB
Amount of memory	2GB
Mass	2g

[Note] Unit: mm

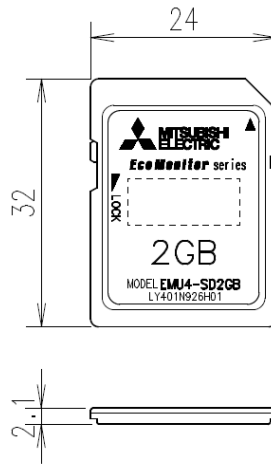

## Service Network

### MITSUBISHI ELECTRIC Multi-Measuring Instrument

Country/Region	Company	Address	Telephone
Australia	Mitsubishi Electric Australia Pty. Ltd.	348 Victoria Road, Rydalmere, N.S.W. 2116, Australia	+61-2-9684-7777
USA	Mitsubishi Electric Automation Inc.	500 Corporate Woods Parkway Vernon Hills, IL 60061, USA	+1-847-478-2100
Brazil	MELCO-TEC Rep. Com. e Assessoria Tecnica Ltda.	Av. Paulista, 1439-Cj.72, Cerqueira Cesar CEP 01311-200, Sao Paulo, SP, CEP:01311-200, Brazil	+55-11-3146-2200
Chile	Rhona S.A.	Agua Santa 4211 P.O. Box 30-D Vina del Mar, Chile	+56-32-2-320-600
China	Mitsubishi Electric Automation (CHINA) Ltd.	No. 1386 Hongqiao Road, Mitsubishi Electric Automation Center Shanghai China, 200336	+86-21-2322-3030
China	Mitsubishi Electric Automation (HongKong) Ltd.	10/F., Manulife Tower, 169 Electric Road, North Point, Hong Kong	+852-2887-8810
Colombia	Proelectrico Representaciones S.A.	Carrera 53 No 29C-73 - Medellin, Colombia	+57-4-235-30-38
Egypt	Cairo Electrical Group	9, Rostoum St. Garden City P.O. Box 165-11516 Maglis El-Shaab, Cairo - Egypt	+20-2-27961337
Europe	Mitsubishi Electric Europe B.V.	Mitsubishi-Electric-Platz1,40882 Ratingen,Germany	+49-2102-486-0
India	Mitlite Electric Company Pvt Ltd	Plot No-32, Sector-6, IMT Maneser,	+91-124-4695300
Indonesia	P. T. Sahabat Indonesia	P.O.Box 5045 Kawasan Industri Pergudangan, Jakarta, Indonesia	+62-(0)21-6610651-9
Korea	Mitsubishi Electric Automation Korea Co., Ltd	9F Gangseo Hangang XI-Tower, 401 YangCheon-Ro, Gangseo-Gu, Seoul, 157-801, Korea	+82-2-3660-9572
Laos	Arounkit Corporation Import-Export Solt Co., Ltd.	Saphanmo Village. Sayaetha District, Vientiane Capital, Laos	+856-20-415899
Lebanon	Comptoir d'Electricite Generale-Liban	Cebaco Center - Block A Autostrade Dora, P.O. Box 11-2597 Beirut - Lebanon	+961-1-240445
Malaysia	Mittrich Sdn Bhd	5 Jalan Pemberita U1/49, Temasya Industrial Park, Glenmarie 40150 Shah Alam, Selangor, Malaysia	+603-5569-3748
Myanmar	Peace Myanmar Electric Co.,Ltd.	NO137/139 Botataung Pagoda Road, Botataung Town Ship 11161, Yangon, Myanmar	+95-(0)1-202589
Nepal	Watt & Volt House	KHA 2-65, Volt House Dillibazar Post Box: 2108, Kathmandu, Nepal	+977-1-4411330
Middle East Arab Countries & Cyprus	Comptoir d'Electricite Generale-International-S.A.L.	Cebaco Center - Block A Autostrade Dora P.O. Box 11-1314 Beirut - Lebanon	+961-1-240430
Pakistan	Prince Electric Co.	1&16 Brandreth Road, Lahore-54000, Pakistan	+92-(0)42-7654342
Philippines	Edison Electric Integrated, Inc.	24th Fl. Galleria Corporate Center, Edsa Cr. Ortigas Ave., Quezon City Metro Manila, Philippines	+63-(0)2-634-8691
Saudi Arabia	Center of Electrical Goods	Al-Shuwayer St. Side way of Salahuddin Al-Ayoubi St. P.O. Box 15955 Riyadh 11454 - Saudi Arabia	+966-1-4770149
Singapore	Mitsubishi Electric Asia Pte. Ltd.	307, Alexandra Road, #05-01/02 Mitsubishi Electric Building, Singapore 159943	+65-6473-2308
South Africa	CBI-electric: low voltage	Private Bag 2016, Isando, 1600, South Africa	+27-(0)11-9282000
Taiwan	Setsuyo Enterprise Co., Ltd	6th Fl., No.105, Wu Kung 3rd, Wu-Ku Hsiang, Taipei, Taiwan, R.O.C.	+886-(0)2-2298-8889
Thailand	United Trading & Import Co., Ltd.	77/12 Bamrungmuang Road, Klong Mahanak, Pomprab Bangkok Thailand	+66-223-4220-3
Uruguay	Fierro Vignoli S.A.	Avda. Uruguay 1274, Montevideo, Uruguay	+598-2-902-0808
Venezuela	Adesco S.A.	Calle 7 La Urbina Edificio Los Robles Locales C y D Planta Baja, Caracas - Venezuela	+58-212-241-9952
Vietnam	Mitsubishi Electric Vietnam Co.,Ltd. Head Office	Unit01-04, 10th Floor, Vincom Center, 72 Le Thanh Ton Street, District 1, Ho Chi Minh City, Vietnam	+84-8-3910-5945
	Mitsubishi Electric Vietnam Co.,Ltd. Hanoi Branch	6th Floor, Detech Tower, 8 Ton That Thuyet Street, My Dinh 2 Ward, Nam Tu Liem District, Hanoi City, Vietnam	+84-4-3937-8075

# MITSUBISHI ELECTRIC CORPORATION

Mitsubishi Electric Corporation (Head Office), Tokyo Building 2-7-3, Marunouchi, Chiyoda-ku, Tokyo 100-8310, Japan, TEL:+81-3-3218-6510